

# INSTALLATION INSTRUCTIONS



## R2380 SPRINTER CAB CHASSIS 11/06-ON

ENSURE INSTRUCTIONS ARE UNDERSTOOD BEFORE INSTALLATION.

### NOTE: NOT TO BE USED ON DUAL CAB VEHICLES

**WARNING** : 1. Do not drill, cut weld or otherwise modify the towbar.  
2. If you are using electric welding on a motor vehicle, always check that the vehicle is not equipped with electronic engine or instrument management equipment. Failure to do so could destroy any onboard computers. If in doubt, check with the vehicle's manufacturer.

**Max. Towing Weight**  
**Rated from 11/06-ON: 2000kg**

1. Ensure all hardware items have been included
2. It is recommended that the instructions are read through and completely understood before making any attempt to fit this product.
3. Be wary of any changes to vehicle designs or other accessories that may conflict with the installation of this product.
4. The high tensile fasteners supplied with this product were used to achieve the specified rating. If replacement is required ensure that fasteners of the same rating & quality are used. Contact an authorised **Hayman Reese** dealer if further information is required.
5. Ensure that all hardware is fastened to torque list below check fasteners on regular basis.
6. Remove the Tail-lamp bracket as shown in figure 1, by removing 4 bolts & disconnecting the wiring for the tail-lamps.
7. Lift towbar into position making sure side arms are to be on inner face of chassis with the tail-lamp bracket side mounts in between.
8. The same bolts used to fit the tail-lamp bracket to the chassis can be used to mount the towbar to the vehicle as well, as shown in Figure 2.
9. Tighten all bolts to torque listing.
10. Refit the tail-light bracket as in reverse of step 6.
11. Towbar load rating sticker provided with this product shall be conspicuously located on inside rear end of the driver's door. **(See diagram below)**.
12. Hayman Reese recommends that you check your tow ball to ensure that it complies with the Australian standards **AS 4177.2**.
13. **PLEASE NOTE:** It is advised to remove your lug or TBM when not actually towing so as to produce a clear view of the vehicles registration plate if obscured, and to also provide maximum available departure angle.

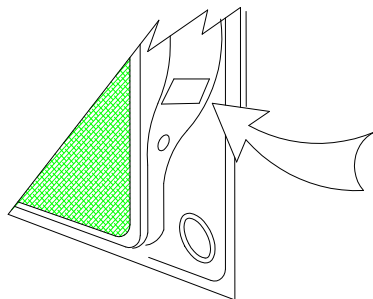

Place load rating sticker  
inside driver's door here

#### RECOMMENDED ASSEMBLY TORQUE LISTING

Diameter	Grade 8.8 Bolt
M6	9.5 Nm
M8	21.7 Nm
M10	43.4 Nm
M12	77.3 Nm
M16	189.8 Nm

#### FOR TOWING PURPOSES ONLY

For towing capacity details please refer to vehicle owner's manual or to the manufacturer. Overloading can void your warranties.

# INSTALLATION INSTRUCTIONS

R2380 SPRINTER CAB CHASSIS 11/06-ON

ENSURE INSTRUCTIONS ARE UNDERSTOOD BEFORE INSTALLATION.



**NOTE: NOT TO BE USED ON DUAL CAB VEHICLES**

Fig 1: Vehicle with towbar fitted shown.



This tail lamp bracket needs to be pulled off, by removing 2 bolts as shown on the top face & 2 bolts at the bottom of the bracket.

Fig 2 : Bolts used to mount the towbar shown.



These 4 bolts used to mount the tail-light bracket is also used to mount the Towbar Sidearms on the inside of the chassis, with the tail-light bracket sidearms in between.

# INSTALLATION INSTRUCTIONS



R2380 SPRINTER CAB CHASSIS 11/06-ON

ENSURE INSTRUCTIONS ARE UNDERSTOOD BEFORE INSTALLATION.

**NOTE: NOT TO BE USED ON DUAL CAB VEHICLES**

## R2380 HITCH ASSEMBLY

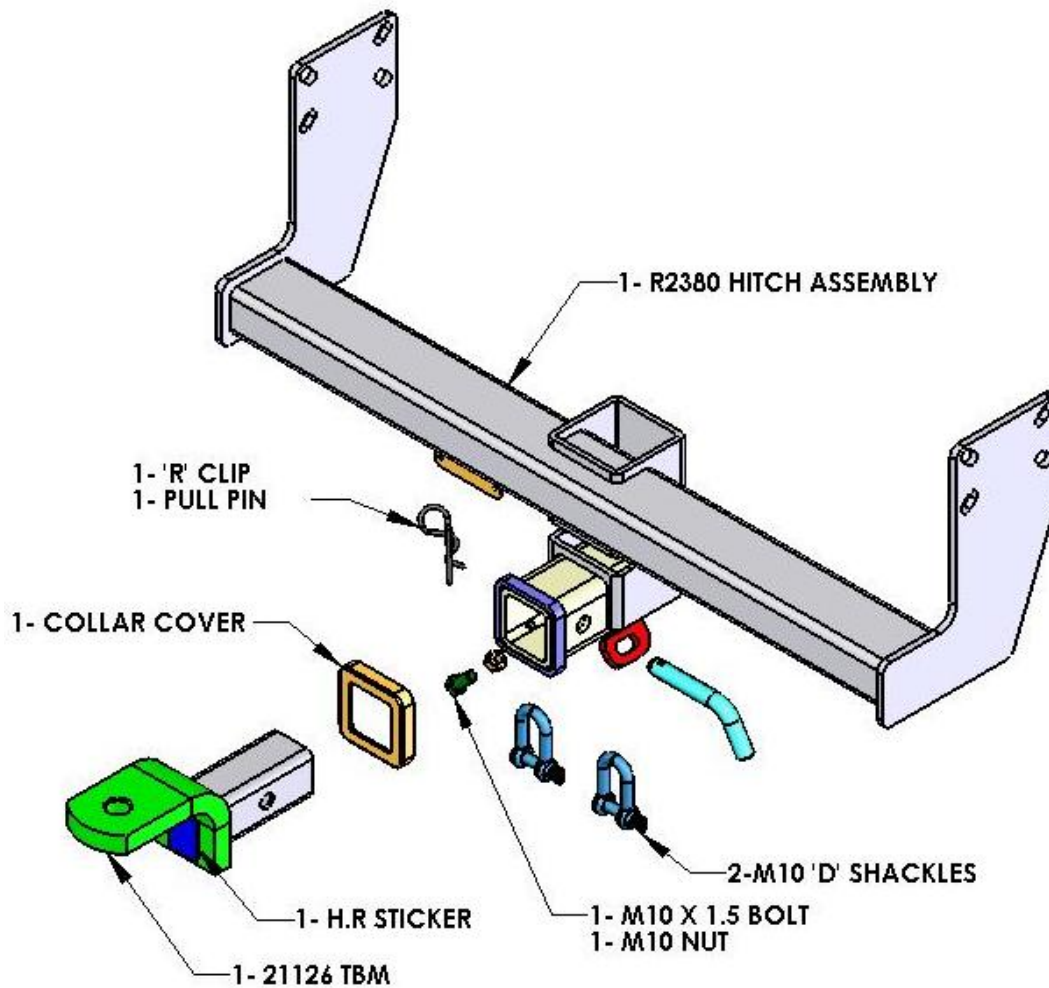

### Tow bar Maintenance and Care.

Hayman Reese recommends that bolt torque's, as listed below, are routinely and regularly inspected and checked for correct tension. Replace any worn or defective parts.

We recommended to remove Tow Ball Mounts (TBM's, tongues or lugs) when not being used for any considerable length of time.

So as to avoid injury, when not towing it is suggested that the tongue, Pull Pin and R-clip are removed then stored in a safe, clean and dry place, away from excessive moisture.

Hitch Pull Pins and spring "R" clips are regularly checked for proper installation. Replace any worn or defective parts.