

**HAYMAN REESE**  
PART No: **R2720W**  
**VOLVO S40 2009 on**

## INSTALLATION INSTRUCTIONS

PLEASE ENSURE THAT INSTRUCTIONS ARE UNDERSTOOD PRIOR TO FITMENT



Installation Time: Approx 90 Mins

**Towbar Installation Instructions**  
**VOLVO S40 2009 on**

**Towbar capacity**

**Part Number R2720W**

**Max Towing Braked 1500kg**  
**Max Static Ball Load 150kg**

Hayman Reese (Cequent)  
PO Box 4050, Dandenong South VIC 3164  
Phone 1800 812 017 Email [info@haymanreese.com.au](mailto:info@haymanreese.com.au)

# HAYMAN REESE

PART No: R2720W

VOLVO S40 2009 on

## INSTALLATION INSTRUCTIONS

PLEASE ENSURE THAT INSTRUCTIONS ARE UNDERSTOOD PRIOR TO FITMENT

### Warning:

1. Do not, drill, cut, weld or otherwise modify the towbar.
2. If you are using electric welding on a motor vehicle, **always** check that the vehicle is not equipped with electronic engine or instrument management equipment. Failure to do so could **destroy** any onboard computers. If in doubt, check with the vehicle's manufacturer.
  
1. **General:** Ensure all hardware items have been included refer to assembly diagram.
2. It is recommended that the instructions are read through and completely understood before making any attempt to fit this product.
3. Be wary of any changes to vehicle designs or other accessories that may conflict with the installation of this product.
4. Before drilling ensure that the area is clear of fuel, electrical & other components.
5. All holes drilled into the body panels shall have all burrs & swarf removed then coated with a suitable rust preventative paint.
6. The high tensile fasteners supplied with this product were used to achieve the specified rating. If replacement is required ensure that fasteners of the same rating & quality are used. Contact an authorised **Hayman Reese** dealer if further information is required.
7. Ensure that all hardware is fastened to torque list below check fasteners on regular basis.
8. Towbar load rating sticker provided with this product shall be conspicuously located on inside rear end of the driver's door. **(See diagram below).**
9. Hayman Reese recommends that you check your tow ball to ensure that it complies with the Australian standards **AS 4177.2**.
10. **PLEASE NOTE:** It is advised to remove your lug or tbm when not actually towing so as to produce a clear view of the vehicles registration plate if obscured, and to also provide maximum available departure angle.

### Tow bar Maintenance and Care.

Hayman Reese recommends that bolt torque's, as listed below, are routinely and regularly inspected and checked for correct tension. Replace any worn or defective parts.

We recommended to remove Tow Ball Mounts (TBM's, tongues or lugs) when not being used for any considerable length of time.

So as to avoid injury, when not towing it is suggested that the tongue, Pull Pin and R-clip are removed then stored in a safe, clean and dry place, away from excessive moisture.

Hitch Pull Pins and spring "R" clips are regularly checked for proper installation. Replace any worn or defective parts.

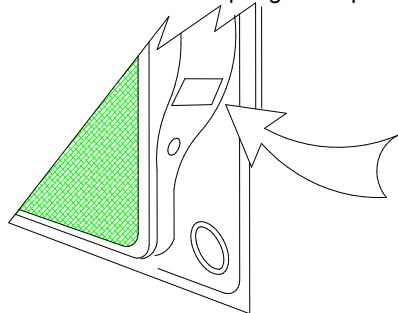

Place load rating sticker  
inside driver's door here

### **RECOMMENDED ASSEMBLY TORQUE LISTING**

#### Diameter Grade 8.8 Bolt

M6	9.5 Nm
M8	21.7 Nm
M10	43.4 Nm
M12	77.3 Nm
M14	146 Nm
M16	189.8 Nm

### **FOR TOWING PURPOSES ONLY**

For towing capacity details please refer to vehicle owner's manual or to the manufacturer. Overloading can void your warranties.

# HAYMAN REESE

PART No: **R2720W**

**VOLVO S40 2009 on**

## INSTALLATION INSTRUCTIONS

PLEASE ENSURE THAT INSTRUCTIONS ARE UNDERSTOOD PRIOR TO FITMENT

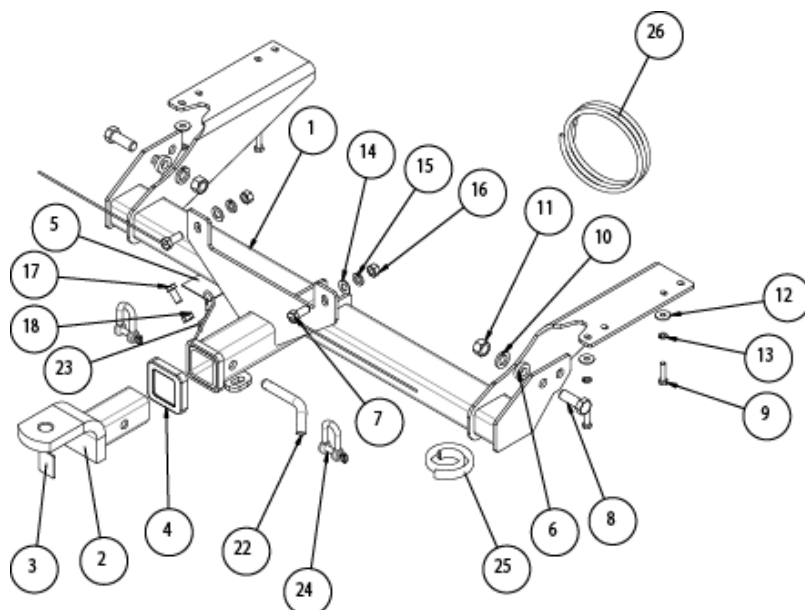

Items 19, 20 and 21 are not shown in the drawing

Figure 1 – Layout Diagram

ITEM NO.	DESCRIPTION	QTY.
1	WELDED ASSEMBLY VOLVO S40/V50	1
2	TBM	1
3	H.R STICKER	1
4	Hitch Box Collar Cover	1
5	ACRYLIC CP	1
6	WASHER	2
7	BOLT & WIRE M12 X 35 X 300	2
8	M16 x 45 2.0P BOLT	2
9	M8 X30 BOLT	4
10	M16 SPRING WASHER	2
11	M16 x 2.0P NUT	2
12	Wshr ft 5/16 x 7/8 x 16 z/p	4
13	M8 SPRING WASHER	4
14	Wshr ft 1/2" x 1-1/8" x 16 z/p	2
15	M12 SPRING WASHER	2
16	M12 x 1.75P NUT	2
17	M10 x 25 1.5P BOLT	1
18	NUT M10 x 1.5P	1
19	FITTING INSTRUCTIONS	1
20	LOAD RATING LABEL	1
21	Warranty Card	1
22	PULL PIN	1
23	SPRING COTTER PIN	1
24	D' SHACKLE	2
25	BUMPER TRIM PINCH WELD 400mm	1
26	WIRING LOOM	1

# HAYMAN REESE

PART No: R2720W

VOLVO S40 2009 on

## INSTALLATION INSTRUCTIONS

PLEASE ENSURE THAT INSTRUCTIONS ARE UNDERSTOOD PRIOR TO FITMENT



Figure 2 – Bumper cut out illustration for Sedan.

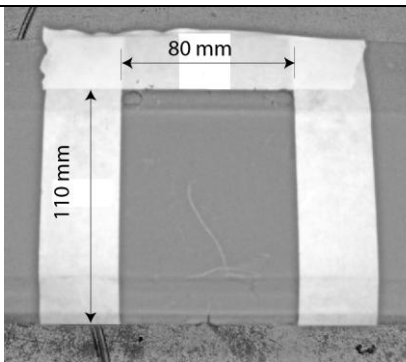

Figure 3 – Bumper Cut out illustrations for Wagon.

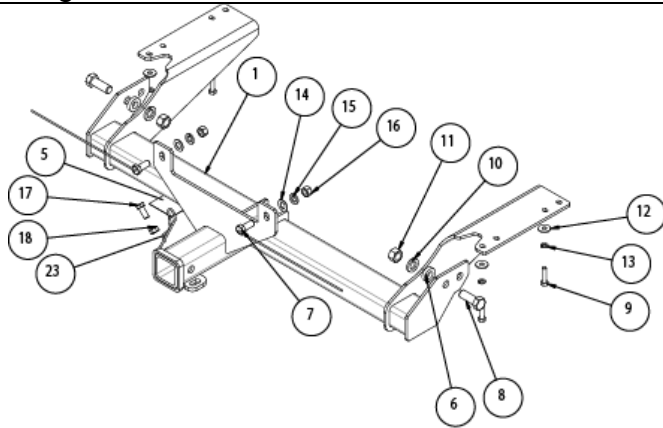

Figure 4 – Locate the Towbar on the vehicle.

Note: Position the vehicle to a safe working height.

1. Remove lower plastic skirt from the bumper and make a cut.
2. Refer to Figure 2 for Sedan.

3. Refer to Figure 3 for Bumper cut out illustration for Wagon. Cut along the centreline.

4. Remove rear most exhaust mounts from chassis on both sides, and let muffler hang.
5. Lift towbar into position so as forward most arms align with exhaust mount holes.
6. Fit M16x95 bolts loosely through shipping hooks.
7. Fit bolts on wires through large holes in impact beam and into rear dropper plate, fit nuts flat washers and spring washers loosely.

Refer to Figure 4.

## HAYMAN REESE

PART No: R2720W

VOLVO S40 2009 on

### INSTALLATION INSTRUCTIONS

PLEASE ENSURE THAT INSTRUCTIONS ARE UNDERSTOOD PRIOR TO FITMENT

- |  |   |
|--|---|
|  | <ol style="list-style-type: none"><li>8. Tighten all bolts to torque listings, as shown on page 2.</li><li>9. Refit the plastic skirt.</li><li>10. Affix the load rating label, as shown on page 2.</li></ol> |
|--|---|



**HAYMAN REESE**  
**PART No: 100475-WL**  
**VOLVO S40**

## **INSTALLATION INSTRUCTIONS**

PLEASE ENSURE THAT INSTRUCTIONS ARE UNDERSTOOD PRIOR TO FITMENT

### **Wiring Loom Installation Instructions**

**VOLVO S40**  
**Part No: 100475-WL**  
**ECU: 04826**

**Tail Harness Length Required: 1800mm**  
**RPA Override Switch Part No: 04848 (If Fitted)**

**Wiring Loom Installation Time: Approx 30 Mins**

Issue Date 07-09-10

Page 1

Part No: 100475-WL

Hayman Reese (Cequent)  
PO Box 4050, Dandenong South VIC 3164  
Phone 1800 812 017 Email [info@haymanreese.com.au](mailto:info@haymanreese.com.au)

[www.haymanreese.com.au](http://www.haymanreese.com.au)



**HAYMAN REESE**  
**PART No: 100475-WL**  
**VOLVO S40**

**INSTALLATION INSTRUCTIONS**

**PLEASE ENSURE THAT INSTRUCTIONS ARE UNDERSTOOD PRIOR TO FITMENT**

1. In the luggage compartment, remove the floor carpet cover (1).
2. Remove the rear trim (2) by first removing the clips.



3. Remove the foam storage tray (1) by first removing the clips.



4. Remove the RHS side trim (1) by first removing the three clips (2).
5. Remove the LHS side trim by first removing the three clips.

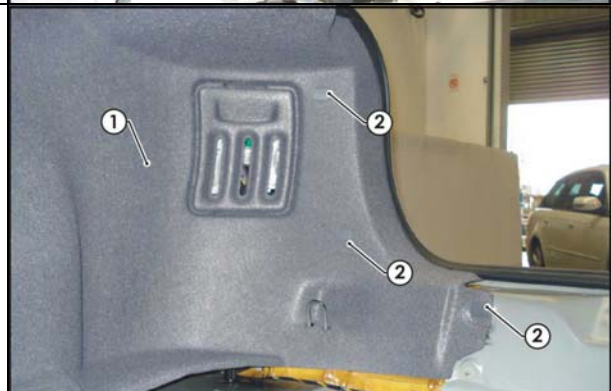

Issue Date 07-09-10

Page 2

Part No: 100475-WL

Hayman Reese (Cequent)  
PO Box 4050, Dandenong South VIC 3164  
Phone 1800 812 017 Email [info@haymanreese.com.au](mailto:info@haymanreese.com.au)

[www.haymanreese.com.au](http://www.haymanreese.com.au)



**HAYMAN REESE**  
**PART No: 100475-WL**  
**VOLVO S40**

**INSTALLATION INSTRUCTIONS**

**PLEASE ENSURE THAT INSTRUCTIONS ARE UNDERSTOOD PRIOR TO FITMENT**

6. In the RHS of the luggage compartment, locate the vehicle factory grommet (1).
7. If the vehicle is fitted with a sunroof, drill a Ø31mm hole in the area (2) next to the grommet (1).
8. If the vehicle does not have a sunroof, remove the vehicle grommet (1) and drill out the grommet hole to Ø31mm.
9. File any rough or sharp edges and spray on rust inhibitor.

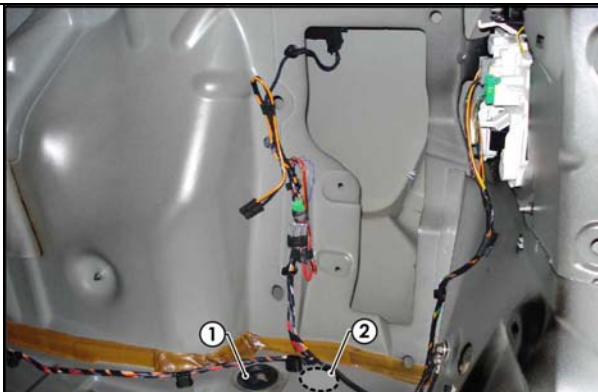

10. Disconnect the RHS tail light grey connector (1) and the green connector (2).
11. Connect the trailer harness (P/No: 100475-WL) patch connector to the RHS tail light assembly.
12. Connect the tail light connectors (1&2) to the trailer harness patch connectors.
13. Connect the trailer harness ground ring terminal to the existing vehicle grounding point (3).
14. Connect the ezy-tap (4) to the vehicle orange power wire (5) and then connect the trailer harness orange power wire terminal (6) to the corresponding wire (5).

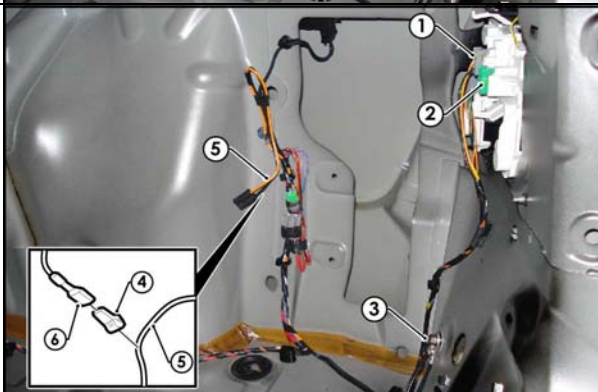

15. Route the trailer harness along the rear of the luggage compartment towards the LHS of the vehicle.
16. Disconnect the LHS tail light green connector (1).
17. Connect the trailer harness patch connector to the LHS tail light assembly.
18. Connect the tail light connector (1) to the trailer harness patch connector.

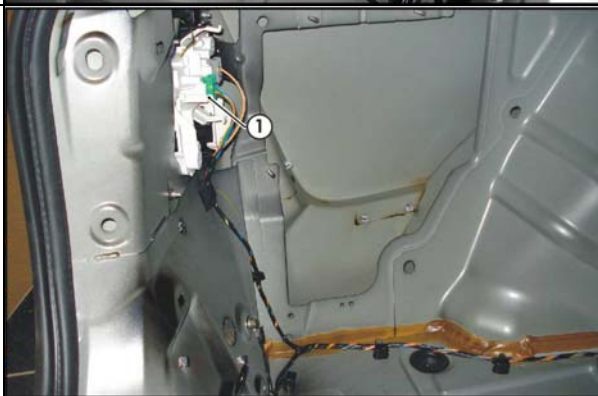

Issue Date 07-09-10

Page 3

Part No: 100475-WL

Hayman Reese (Cequent)  
PO Box 4050, Dandenong South VIC 3164  
Phone 1800 812 017 Email [info@haymanreese.com.au](mailto:info@haymanreese.com.au)

[www.haymanreese.com.au](http://www.haymanreese.com.au)





**HAYMAN REESE**  
**PART No: 100475-WL**  
**VOLVO S40**

**INSTALLATION INSTRUCTIONS**

**PLEASE ENSURE THAT INSTRUCTIONS ARE UNDERSTOOD PRIOR TO FITMENT**

19. Connect the trailer harness 12-way connector (1) to the ECU (04826) (2).

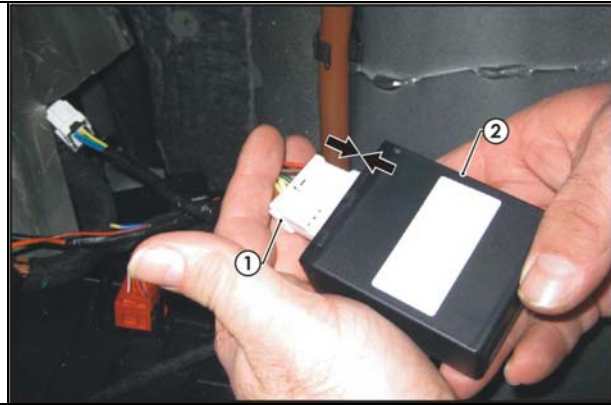

20. In the LHS rear quarter corner, apply double sided tape to the ECU and adhere it to the vehicle sheet metal (1).

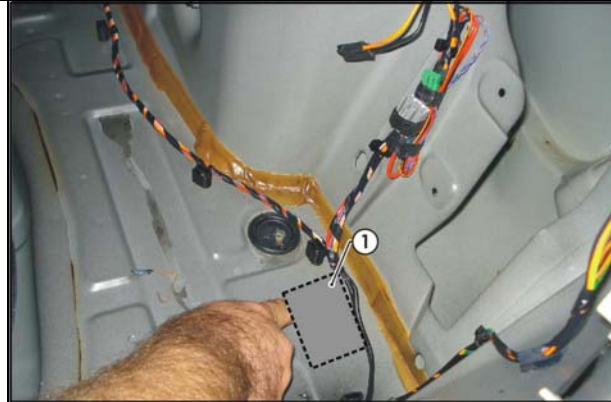

21. Mount the trailer socket to the towbar mounting bracket using M4 fasteners (not supplied).  
22. Route the tail harness (tail length 1800mm) up through the previously drilled out hole.  
23. Ensure the tail harness grommet is seated correctly and secured in place with a cable tie (not supplied).  
24. Connect the tail harness 8-way connector (1) to the trailer harness mating 8-way connector (2).

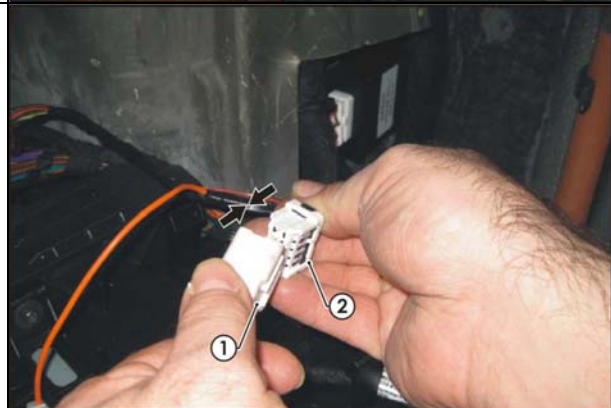

Issue Date 07-09-10

Page 4

Part No: 100475-WL

Hayman Reese (Cequent)  
PO Box 4050, Dandenong South VIC 3164  
Phone 1800 812 017 Email [info@haymanreese.com.au](mailto:info@haymanreese.com.au)

[www.haymanreese.com.au](http://www.haymanreese.com.au)



**HAYMAN REESE**  
**PART No: 100475-WL**  
**VOLVO S40**

**INSTALLATION INSTRUCTIONS**

**PLEASE ENSURE THAT INSTRUCTIONS ARE UNDERSTOOD PRIOR TO FITMENT**

- |  |  |
|--|--|
| <ol style="list-style-type: none"><li>25. Test the Trailer Harness function using a Light Board or multimeter.</li><li>26. Secure all Harnesses using cables ties (not supplied).</li><li>27. Re-fit all removed parts and secure all fasteners, ensuring there are no squeaks or rattles.</li><li>28. Place instructions in glove box after fitment</li></ol> |  |
|--|--|

Issue Date 07-09-10

Page 5

Part No: 100475-WL

Hayman Reese (Cequent)  
PO Box 4050, Dandenong South VIC 3164  
Phone 1800 812 017 Email [info@haymanreese.com.au](mailto:info@haymanreese.com.au)

[www.haymanreese.com.au](http://www.haymanreese.com.au)

