

HAYMAN REESE
PART No: **02747W**
Mazda 2 Hatch 2011-On

INSTALLATION INSTRUCTIONS

PLEASE ENSURE THAT ALL INSTRUCTIONS ARE UNDERSTOOD PRIOR TO FITMENT



Installation Time: Approx **50** Mins

Towbar Installation Instructions
Mazda 2 Hatch 2011-On

Towbar capacity

Part Number **02747W**

Max Towing Braked 700kg
Max Static Ball Load 70kg

Hayman Reese (Cequent)
PO Box 4050, Dandenong South VIC 3164
Phone 1800 812 017 Email info@haymanreese.com.au

HAYMAN REESE

PART No: 02747W

Mazda 2 Hatch 2011-On

INSTALLATION INSTRUCTIONS

PLEASE ENSURE THAT INSTRUCTIONS UNDERSTOOD PRIOR TO FITMENT

Warning:

1. Do not, drill, cut, weld or otherwise modify the towbar.
2. If you are using electric welding on a motor vehicle, **always** check that the vehicle is not equipped with electronic engine or instrument management equipment. Failure to do so could **destroy** any onboard computers. If in doubt, check with the vehicle's manufacturer.

1. **General:** Ensure all hardware items have been included refer to assembly diagram.
2. It is recommended that the instructions are read through and completely understood before making any attempt to fit this product.
3. Be wary of any changes to vehicle designs or other accessories that may conflict with the installation of this product.
4. Before drilling ensure that the area is clear of fuel, electrical & other components.
5. All holes drilled into the body panels shall have all burrs & swarf removed then coated with a suitable rust preventative paint.
6. The high tensile fasteners supplied with this product were used to achieve the specified rating. If replacement is required ensure that fasteners of the same rating & quality are used. Contact an authorised **Hayman Reese** dealer if further information is required.
7. Ensure that all hardware is fastened to torque list below check fasteners on regular basis.
8. Towbar load rating sticker provided with this product shall be conspicuously located on inside rear end of the driver's door. **(See diagram below).**
9. Hayman Reese recommends that you check your tow ball to ensure that it complies with the Australian standards **AS 4177.2**.
10. **PLEASE NOTE:** It is advised to remove your lug or tbm when not actually towing so as to produce a clear view of the vehicles registration plate if obscured, and to also provide maximum available departure angle.

Tow bar Maintenance and Care.

Hayman Reese recommends that bolt torque's, as listed below, are routinely and regularly inspected and checked for correct tension. Replace any worn or defective parts.

We recommended to remove Tow Ball Mounts (TBM's, tongues or lugs) when not being used for any considerable length of time.

So as to avoid injury, when not towing it is suggested that the tongue, Pull Pin and R-clip are removed then stored in a safe, clean and dry place, away from excessive moisture.

Hitch Pull Pins and spring "R" clips are regularly checked for proper installation. Replace any worn or defective parts.

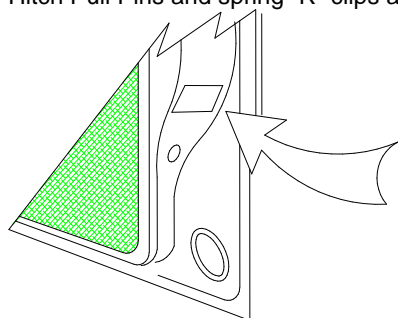

Place load rating sticker
inside driver's door here

RECOMMENDED ASSEMBLY TORQUE LISTING

Diameter Grade 8.8 Bolt

M6	9.5 Nm
M8	21.7 Nm
M10	43.4 Nm
M12	77.3 Nm
M14	146 Nm
M16	189.8 Nm

FOR TOWING PURPOSES ONLY

For towing capacity details please refer to vehicle owner's manual or to the manufacturer. Overloading can void your warranties.

Issue Date 1/11/10

Page 2

Part No: 02747W

HAYMAN REESE

PART No: 02747W

Mazda 2 Hatch 2011-On

INSTALLATION INSTRUCTIONS

PLEASE ENSURE THAT INSTRUCTIONS UNDERSTOOD PRIOR TO FITMENT

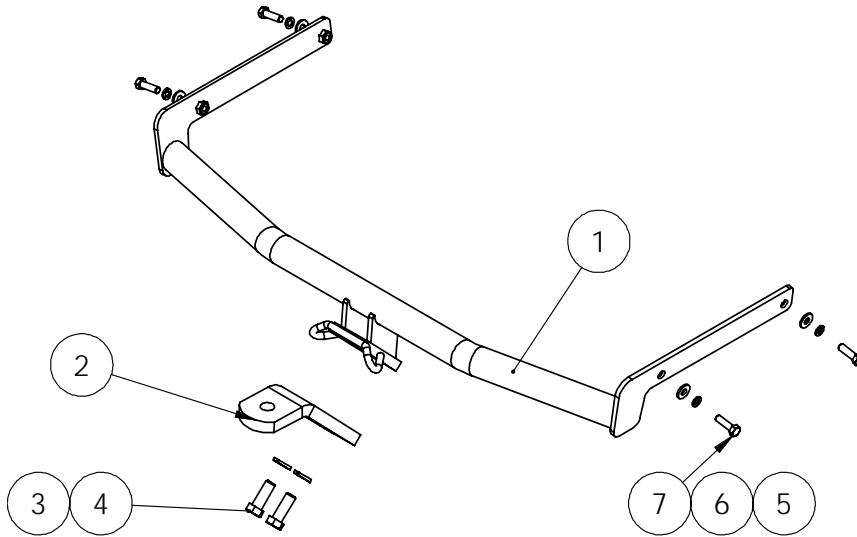

QTY.	DESCRIPTION	ITEM NO.
1	WELD ASSY.	1
1	LUG	2
2	M16 X 5 X 3.5 SPRING WASHER	3
2	M16 x 45 2.0P BOLT	4
4	WSHR FT M10 X 25.4 X 3	5
4	M10 X 3.5 X 2.2 SPRING WSHR	6
4	M10 - 1.5 x 35mm BOLT	7

ADDITIONAL ITEMS

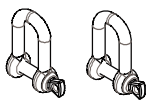

D SCHAKLES

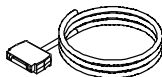

WIRING LOOM



FITTING INSTRUCTIONS



LOAD RATING LABEL



WARRANTY CARD



HAYMAN REESE

PART No: 02747W

Mazda 2 Hatch 2011-On

INSTALLATION INSTRUCTIONS

PLEASE ENSURE THAT INSTRUCTIONS UNDERSTOOD PRIOR TO FITMENT

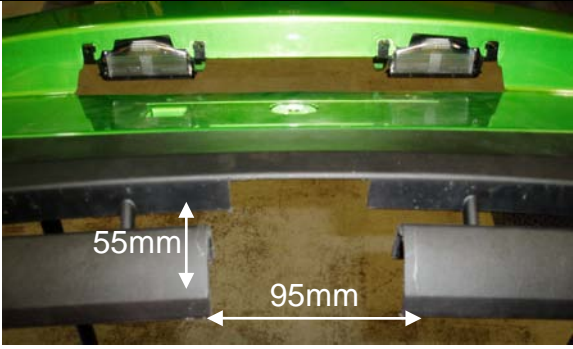
	<ol style="list-style-type: none">1. Remove 4 screws and 1 skivet around wheel arch area on both sides.2. Remove 2 skrivets under the bumper.3. Open the booth lid and remove 2 screws between the cavities.
	<ol style="list-style-type: none">4. Loosen taillight assemblies via accessing from inside the booth.5. Remove bumper and disconnect any wirings connecting to the bumper.
	<ol style="list-style-type: none">6. Insert towbar into chassis rails, fit tow bar to chassis rails using M10 bolts, flat washers and spring washers supplied.7. Torque all fastens to specifications on page 2.
	<ol style="list-style-type: none">8. Using number plate lights as a guide, cut 95mm wide by 55mm deep from the bottom of the bumper. Also cut horizontal section above grill.9. Refit bumper bar to vehicle.

HAYMAN REESE
PART No: 100073-WL
MAZDA 2 HATCH
DE11 & DE12 2008 ONWARDS
INSTALLATION INSTRUCTIONS

PLEASE ENSURE THAT INSTRUCTIONS ARE UNDERSTOOD PRIOR TO FITMENT

Wiring Loom Installation Instructions

MAZDA 2 HATCH
DE11 & DE12 2008 ONWARDS
Part No: 100073-WL

Tail Harness Length Required: 1200mm
RPA Override Switch Part No: 04848 (If Fitted)

Wiring Loom Installation Time: Approx 30 Mins

Issue Date 28-10-10

Page 1

Part No: 100073-WL

Hayman Reese (Cequent)
PO Box 4050, Dandenong South VIC 3164
Phone 1800 812 017 Email info@haymanreese.com.au

www.haymanreese.com.au



HAYMAN REESE
PART No: 100073-WL
MAZDA 2 HATCH
DE11 & DE12 2008 ONWARDS
INSTALLATION INSTRUCTIONS

PLEASE ENSURE THAT INSTRUCTIONS ARE UNDERSTOOD PRIOR TO FITMENT

1. In the luggage compartment, remove the floor cover carpet (1).
2. Remove the parcel shelf (2) and fold the rear seats (3) forwards.

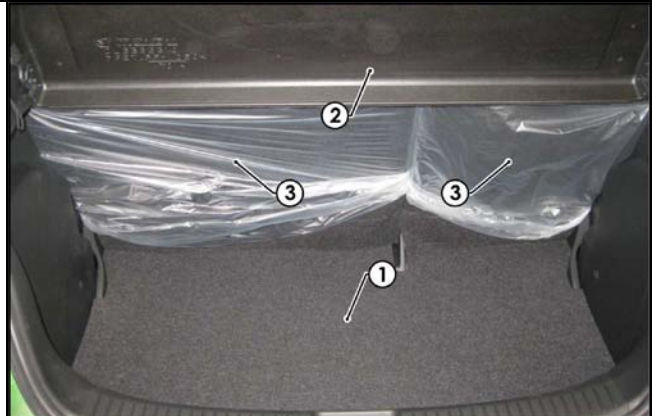

3. Remove the rear trim (1) by first removing the two clips (2).

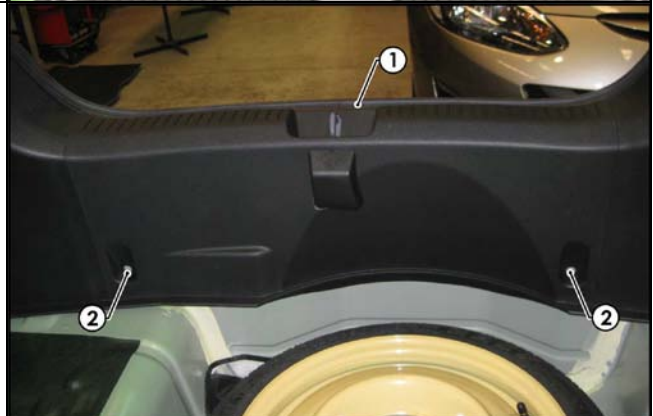

4. Dislodge the LHS side trim (1) by first removing any scrivenets (2) or fasteners (2).



Issue Date 28-10-10

Page 2

Part No: 100073-WL

Hayman Reese (Cequent)
PO Box 4050, Dandenong South VIC 3164
Phone 1800 812 017 Email info@haymanreese.com.au

www.haymanreese.com.au



HAYMAN REESE
PART No: 100073-WL
MAZDA 2 HATCH
DE11 & DE12 2008 ONWARDS
INSTALLATION INSTRUCTIONS

PLEASE ENSURE THAT INSTRUCTIONS ARE UNDERSTOOD PRIOR TO FITMENT

5. Dislodge the RHS side trim (1) by first removing any scrivenets (2) or fasteners (2).
6. Disconnect the RHS light 2-way connector (3).

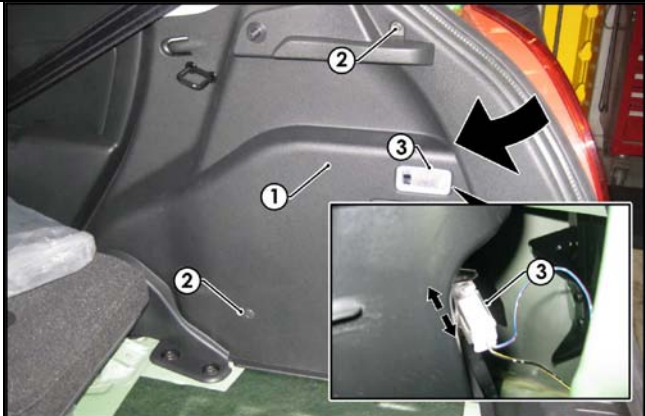

7. From outside the vehicle, remove the RHS rear grommet (1).
8. Drill out the grommet hole to Ø31mm.
9. File any rough or sharp edges and spray on rust inhibitor.



10. From inside the luggage compartment, disconnect the LHS tail light 6-way connector (1).
11. Patch in the trailer patch mating 6-way connectors (2).
12. Route the trailer patch harness (P/No: 100073-WL) from the LHS tail light assembly towards the rear of the luggage compartment.

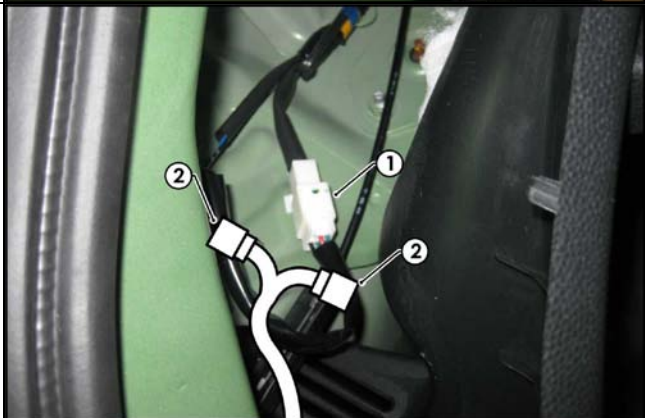

Issue Date 28-10-10

Page 3

Part No: 100073-WL

Hayman Reese (Cequent)
PO Box 4050, Dandenong South VIC 3164
Phone 1800 812 017 Email info@haymanreese.com.au

www.haymanreese.com.au



HAYMAN REESE
PART No: 100073-WL
MAZDA 2 HATCH
DE11 & DE12 2008 ONWARDS
INSTALLATION INSTRUCTIONS

PLEASE ENSURE THAT INSTRUCTIONS ARE UNDERSTOOD PRIOR TO FITMENT

13. Route the trailer patch harness (1) along the rear of the luggage compartment and towards the RHS

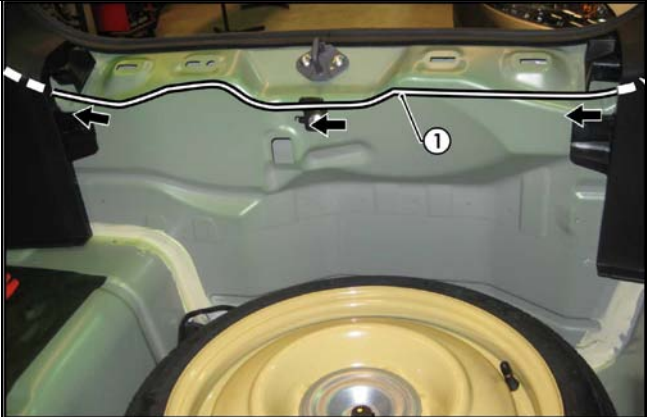

14. Route the trailer patch harness (1) towards the RHS tail light assembly.
15. Disconnect the RHS tail light 6-way connector (2).
16. Patch in the trailer patch mating 6-way connectors (3).

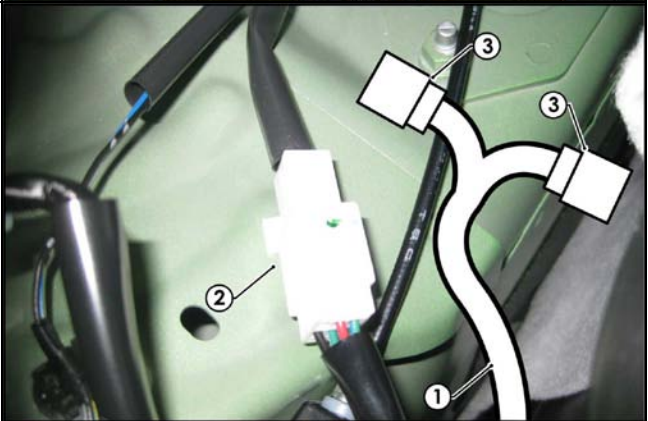

17. Using a self tapping tech screw (1), secure the trailer patch harness ground ring terminal (2) to the RHS vehicle sheet metal as shown.

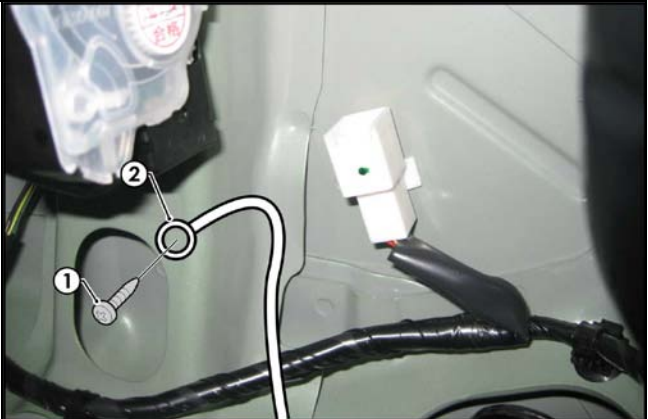

Issue Date 28-10-10

Page 4

Part No: 100073-WL

Hayman Reese (Cequent)
PO Box 4050, Dandenong South VIC 3164
Phone 1800 812 017 Email info@haymanreese.com.au

HAYMAN REESE
PART No: 100073-WL
MAZDA 2 HATCH
DE11 & DE12 2008 ONWARDS
INSTALLATION INSTRUCTIONS

PLEASE ENSURE THAT INSTRUCTIONS ARE UNDERSTOOD PRIOR TO FITMENT

18. Mount the trailer socket (1) to the towbar mounting bracket using M4 fasteners (not supplied).
19. Route the tail harness (tail length 1200mm) (2) across the towbar, towards the RHS of the vehicle and up through the previously drilled out grommet hole.
20. Ensure the tail harness grommet is seated correctly and secure in place using a cable tie (not supplied).



21. Connect the tail harness 8-way connector (1) to the trailer harness mating 8-way connector (2).

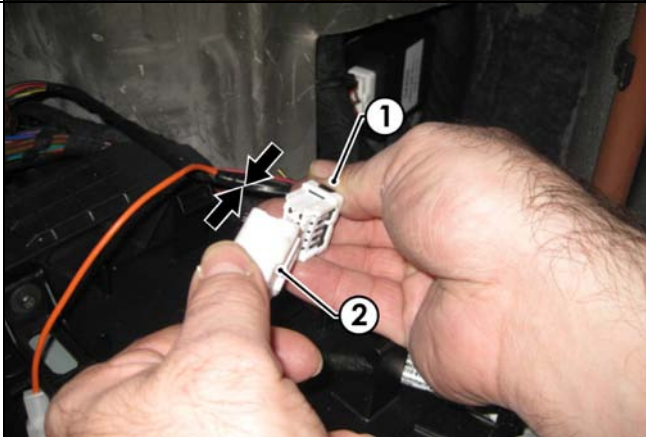

22. Test the trailer harness function using a light board or multimeter.
23. Secure all harnesses using cables ties (not supplied).
24. Re-fit all removed parts and secure all fasteners, ensuring there are no squeaks or rattles.
25. Place the instructions in the glove box after fitment.

Issue Date 28-10-10

Page 5

Part No: 100073-WL

Hayman Reese (Cequent)
PO Box 4050, Dandenong South VIC 3164
Phone 1800 812 017 Email info@haymanreese.com.au

www.haymanreese.com.au

