

HAYMAN REESE

PART No: 03260R

JAYCO FA25 SERIES CL4

INSTALLATION INSTRUCTIONS

PLEASE ENSURE THAT INSTRUCTIONS ARE UNDERSTOOD PRIOR TO FITMENT
PLACE THESE INSTRUCTIONS IN THE VEHICLE'S GLOVEBOX AFTER INSTALLATION IS COMPLETED



Installation Time: Approx 20 Mins

Towbar Installation Instructions

JAYCO FA25 SERIES CL4

Towbar capacity

Part Number 03260R

Max Towing Braked 1700 kg

Max Towing Unbraked 750 kg

Max Static Ball Load 170 kg

Hayman Reese (Cequent)
PO Box 4050, Dandenong South VIC 3164
Phone 1800 812 017 Email info@haymanreese.com.au

www.haymanreese.com.au



HAYMAN REESE

PART No: 03260R

JAYCO FA25 SERIES CL4

INSTALLATION INSTRUCTIONS

PLEASE ENSURE THAT INSTRUCTIONS ARE UNDERSTOOD PRIOR TO FITMENT
PLACE THESE INSTRUCTIONS IN THE VEHICLE'S GLOVEBOX AFTER INSTALLATION IS COMPLETED

Warning:

1. Do not, drill, cut, weld or otherwise modify the towbar.
2. If you are using electric welding on a motor vehicle, **always** check that the vehicle is not equipped with electronic engine or instrument management equipment. Failure to do so could **destroy** any on board computers. If in doubt, check with the vehicle's manufacturer.
3. If TBM is used in inverted position tow ball may make contact with rear tailgate when lowered, which could cause damage.

General:

1. Ensure all hardware items have been included refer to assembly diagram.
2. It is recommended that the instructions are read through and completely understood before making any attempt to fit this product.
3. Be wary of any changes to vehicle designs or other accessories that may conflict with the installation of this product.
4. Before drilling ensure that the area is clear of fuel, electrical & other components.
5. All holes drilled into the body panels shall have all burrs & swarf removed then coated with a suitable rust preventative paint.
6. The high tensile fasteners supplied with this product were used to achieve the specified rating. If replacement is required ensure that fasteners of the same rating & quality are used. Contact an authorised **Hayman Reese** dealer if further information is required.
7. Ensure that all hardware is fastened to torque list below check fasteners on regular basis.
8. Towbar load rating sticker provided with this product shall be conspicuously located on inside rear end of the driver's door. **(See diagram below).**
9. Hayman Reese recommends that you check your tow ball to ensure that it complies with the Australian standards **AS 4177.2**.
10. **PLEASE NOTE:** It is advised to remove your LUG or TBM when not actually towing so as to produce a clear view of the vehicles registration plate if obscured, and to also provide maximum available departure angle.

Tow bar Maintenance and Care.

Hayman Reese recommends that bolt torque's, as listed below, are routinely and regularly inspected and checked for correct tension. Replace any worn or defective parts.

We recommended to remove Tow Ball Mounts (TBM's, tongues or lugs) when not being used for any considerable length of time.

So as to avoid injury, when not towing it is suggested that the tongue, Pull Pin and R-clip are removed then stored in a safe, clean and dry place, away from excessive moisture.

Hitch Pull Pins and spring "R" clips are regularly checked for proper installation. Replace any worn or defective parts.

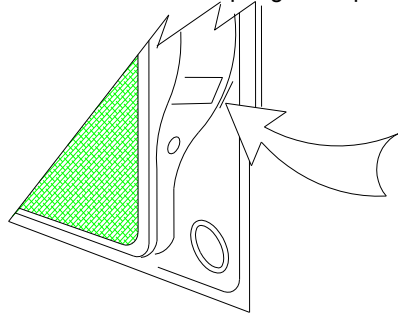

**Place load rating sticker
inside driver's door here**

FOR TOWING PURPOSES ONLY

**For towing capacity details please refer to vehicle
owner's manual or to the manufacturer. Overloading can
void your warranties.**

Hayman Reese (Cequent)
PO Box 4050, Dandenong South VIC 3164
Phone 1800 812 017 Email info@haymanreese.com.au

www.haymanreese.com.au



HAYMAN REESE

PART No: 03260R

JAYCO FA25 SERIES CL4

INSTALLATION INSTRUCTIONS

PLEASE ENSURE THAT INSTRUCTIONS ARE UNDERSTOOD PRIOR TO FITMENT
PLACE THESE INSTRUCTIONS IN THE VEHICLE'S GLOVEBOX AFTER INSTALLATION IS COMPLETED

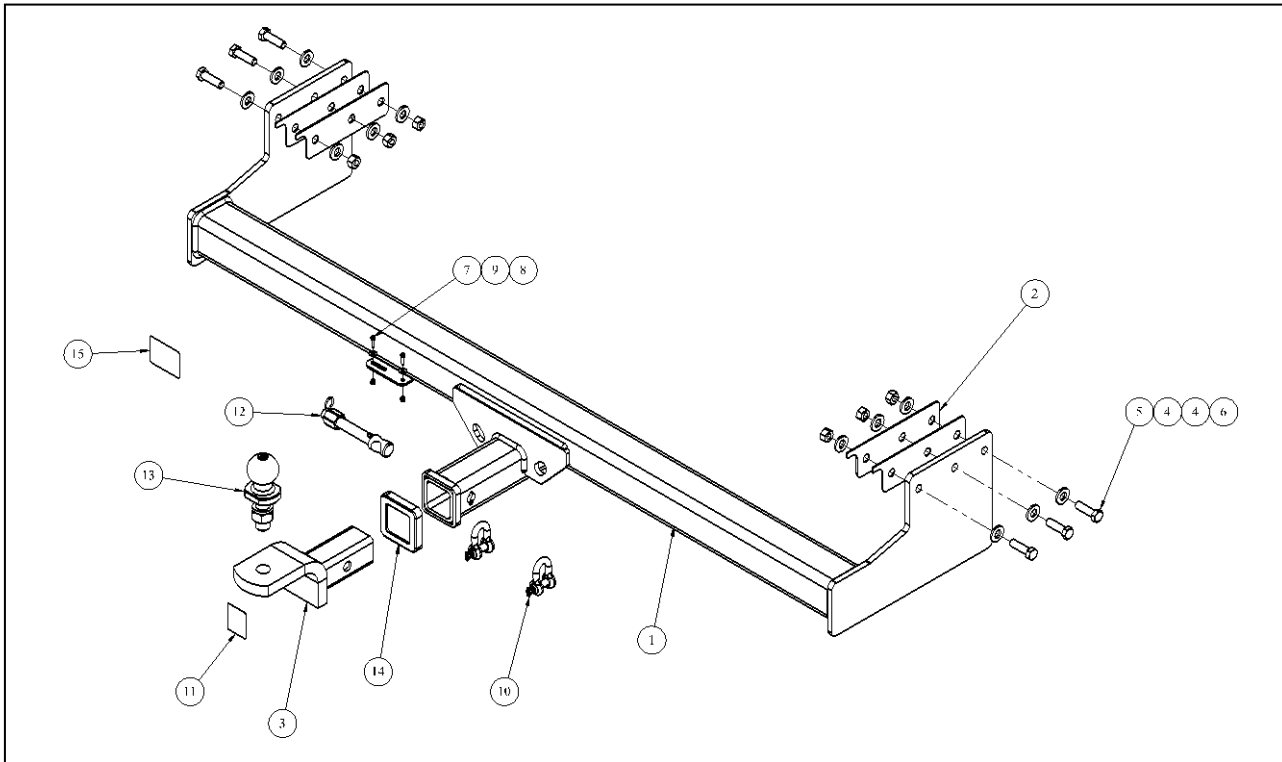

ITEM	DESCRIPTION	QTY
1	JAYCO FA25 WELDED ASSEMBLY	1
2	SHIM PLATE	4
3	TRAILER BALL MOUNT	1
4	WASHER PLAIN 1/2X1-1/8X16G	12
5	SET SCREW M12-1.75x40 GR10.9	6
6	M12x1.75 HEX NUT PC8	6
7	SCREW PAN HD M4 X 16 X 0.7P G4.6	2
8	NUT NYLON LOCK HEX HD M4X0.7P G8	2

ITEM	DESCRIPTION	QTY
9	WASHER PLAIN3/16 X 1/2 X 20G	2
10	"D" SHACKLE 10mm	2
11	H.R STICKER	1
12	ANTI-RATTLE PULL PIN ASSY GOLD	1
13	HR TOWBALL	1
14	HITCH BOX COLLAR COVER	1
15	ACRYLIC COMPLIANCE LABEL	1

Hayman Reese (Cequent)
PO Box 4050, Dandenong South VIC 3164
Phone 1800 812 017 Email info@haymanreese.com.au

www.haymanreese.com.au



HAYMAN REESE

PART No: 03260R

JAYCO FA25 SERIES CL4

INSTALLATION INSTRUCTIONS

PLEASE ENSURE THAT INSTRUCTIONS ARE UNDERSTOOD PRIOR TO FITMENT
PLACE THESE INSTRUCTIONS IN THE VEHICLE'S GLOVEBOX AFTER INSTALLATION IS COMPLETED

1. Remove 2 off Screws securing plug to rear panel, underneath vehicle.

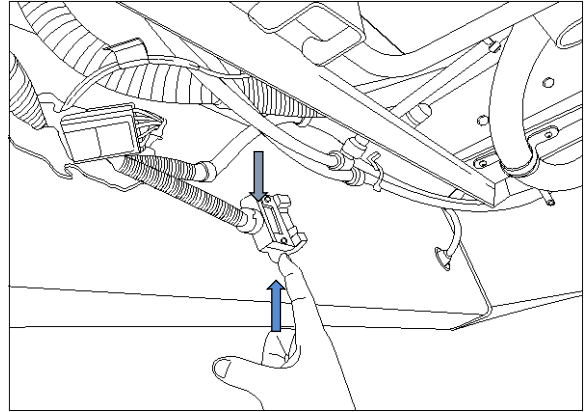

2. Loosely secure Towbar onto right hand chassis rail with 3 off M12 x 40 Set Screws provided, complete with 2 x Flat Washers and 1 x M12 nut per Set Screw.

If a gap is present, insert supplied shim plates, with shim tab facing rearwards (refer to exploded diagram on page 3), between chassis rail and side arm. Ensure to distribute shims evenly between LH and RH sides to keep bar centred.

Torque M12 fasteners to **109 N.m**

Repeat for opposite side.

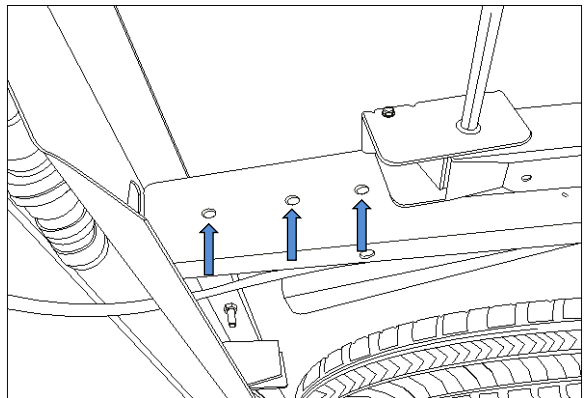

3. Secure plug on to Towbar's plug bracket using two x M4 Screws provided, complete with 1 x Flat Washer and 1 x Nyloc Nut per Screw.

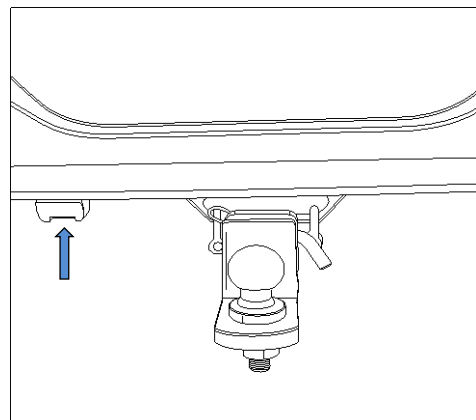

Hayman Reese (Cequent)
PO Box 4050, Dandenong South VIC 3164
Phone 1800 812 017 Email info@haymanreese.com.au

www.haymanreese.com.au





FITTING INSTRUCTIONS

Smart Pin (55070BL)

• These fitting instructions are supplied to ensure understanding of how the SMART PIN should be fitted and used correctly.

• Once installed, we recommend **ALL** instructions are kept and placed in the vehicle glove box.

NOTE: Routine maintenance and inspection of the towbar & SMART PIN is required. Regularly inspect for wear and check the tightness of the SMART PIN NUT. Follow instructions below to retighten the nut when necessary.

***Do not tow with your vehicle if the R CLIP or the SMART PIN NUT is loose or missing. Replacement parts are available from your Hayman Reese Distributor.**

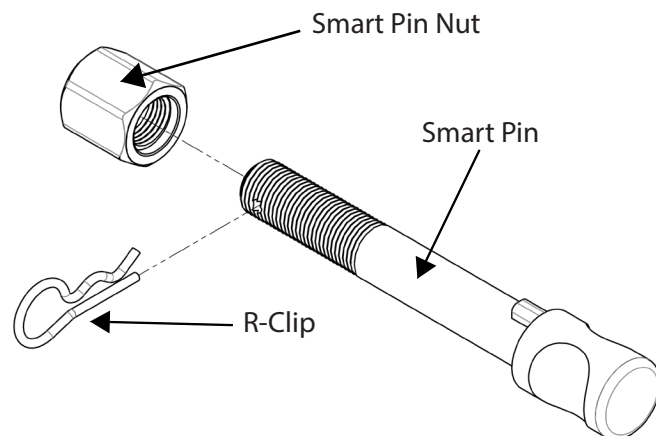
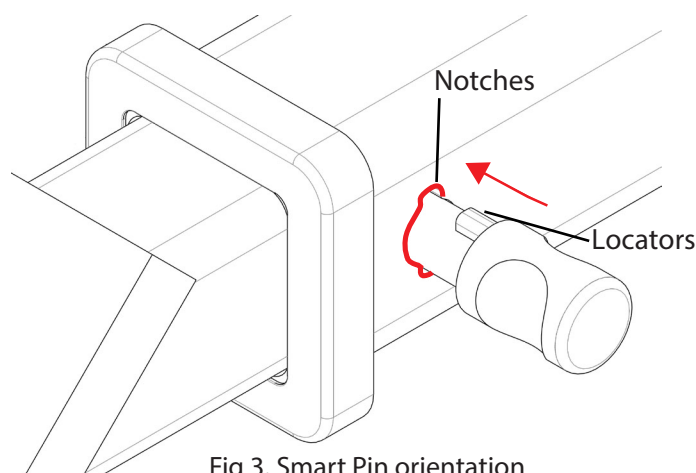
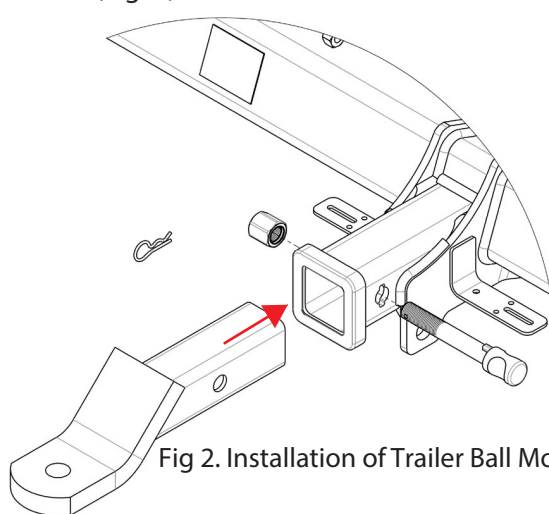

Fig 1. Smart Pin assembly

STEP 1 Insert Trailer Ball Mount (TBM) into towbar HITCHBOX, aligning hole in TBM SHANK with hole in HITCHBOX (Fig. 2).



STEP 2 Insert SMART PIN through hole in HITCHBOX and hole in TBM SHANK; ensure the LOCATORS are inserted into the NOTCHES in the HITCHBOX (Fig. 3).

STEP 3 Screw SMART PIN NUT onto SMART PIN; tighten SMART PIN NUT until finger tight, ensuring TBM is restrained from movement.

STEP 4 Tighten SMART PIN NUT by turning nut a further 1/8th of a turn in the clockwise direction using a 24mm spanner (Fig 4).

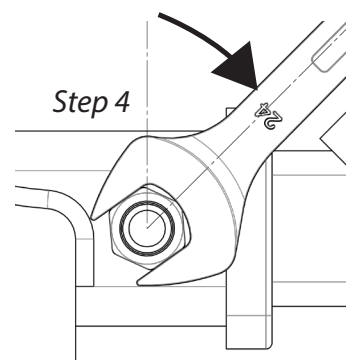

STEP 5 Install SMART PIN R CLIP through the hole on the SMART PIN (Fig. 1).

