



TOWBAR INSTALLATION INSTRUCTIONS

PART NUMBER 03274RW

VOLKSWAGEN AMAROK 2H CL4 UTE



PRODUCT DETAILS:

Part Number:	03274RW	Maximum Towing Braked:	3500	kg
ECU Number:	WLE70004	Maximum Towing Unbraked:	750	kg
Tail Harness Length Required:	1200 mm	Maximum Static Ball Load:	300	kg
TBM/Lug Part Number:	21161			
Wiring Part Number:	WLL9004			

FITTING DETAILS:

Towbar Installation Time:	30 Mins.	Hayman Reese SmartCODE Solution Required:	YES
Wiring Installation Time:	30 Mins.	RPA Disable/Other	YES
Total Installation Time:	60 Mins.	Notes:	
Bumper Cut Required:	No	<ul style="list-style-type: none">• Electric Brake = Brack Prep Connector• RPA Automatically disable when vehicle is coded	
		*See Appendix for added information	



TOWBAR INSTALLATION INSTRUCTIONS

PART NUMBER 03274RW

VOLKSWAGEN AMAROK 2H CL4 UTE

ENSURE THAT INSTRUCTIONS ARE UNDERSTOOD PRIOR TO FITMENT.

i BEFORE YOU START:

Hayman Reese recommends that instructions are read completely prior to fitment. Check all hardware items have been included refer to assembly diagram. Please ensure this towbar is only fitted to vehicle models as per Hayman Reese application guide (www.haymanreese.com.au).

Bumper Cuts



Vehicle and bumper variations can and do occur during vehicle manufacture after initial towbar design. Fitment of towbar to vehicle and accuracy of bumper cut must be assessed prior to any bumper modifications made. Incorrect bumper cuts are not covered under Hayman Reese warranty.

NOTE: Bumper cuts need to be approached with care, refer to notes below.

- Bumper centreline – where the centreline of the bumper needs to be determined, the installer must assess centre point by measurement of bumper width or determining two symmetrical reference points to give centreline.
- Bumper edge – To assist with accurate bumper cut measurement, reference to the start of the bumper edge is now being commonly used.
 - Measure from bottom edge along bumper and around corner to the 70 mm point (Figure 1).
 - Do not measure from visible bumper front of corner, upwards (Figure 2).

Drilling

- For any required drilling during installation, ensure that the area is clear of fuel, electrical & other components that may be damaged.
- All holes drilled into the body panels shall have all burrs & swarf removed then coated with a suitable rust preventative paint.

Bolts/Fasteners

- Ensure that all hardware is fastened to correct torque as specified in this fitting instruction.
- All fasteners supplied with this product are used to achieve a specified clamp loading. If replacement is required ensure that fasteners of the same grade and class are used.



NOTE: Achieving correct torque is critical to proper installation and responsibility of the installer. Towbar failures attributed to tension issues from over tightening or under tightening are not covered by Hayman Reese warranty.

Product Labels

- Towbar load rating sticker provided with this product shall be conspicuously located on inside rear end of the driver's door.
- Powertrain Control Module (PCM)/Body Control Module (BCM) upgrade warning label will be provided in towbar kit for vehicles as required. Affix warning label in door and owner's handbook.

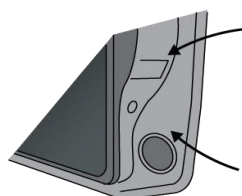

Place **Load Rating sticker** inside driver's door here

Place **Vehicle PCM/ BCM upgrade warning label** in door AND on front cover of owner's service handbook

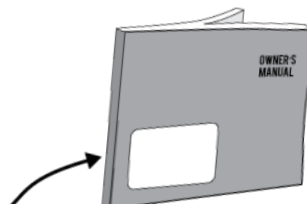

WARNING:

**Do not, drill, cut, weld or otherwise modify the towbar.
FOR TOWING PURPOSES ONLY - This towbar is designed and tested by Hayman Reese to adhere to ADR 62/02 which provides only for the expected load demands of towing.**

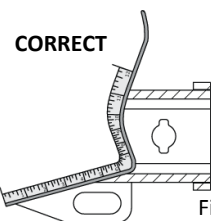

Figure 1

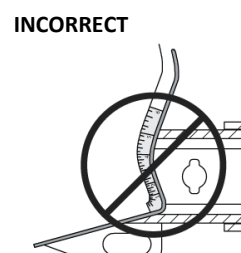

Figure 2



TOWBAR INSTALLATION INSTRUCTIONS

PART NUMBER 03274RW

VOLKSWAGEN AMAROK 2H CL4 UTE

i TOWBAR ASSEMBLY DIAGRAM

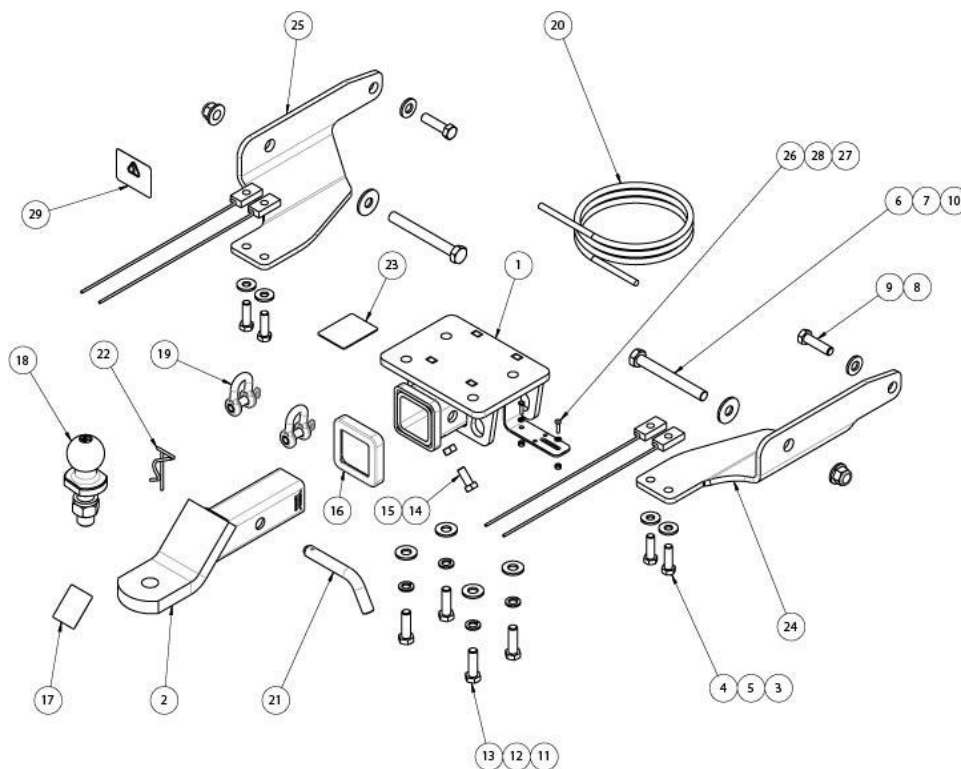

ITEM	DESCRIPTION	QTY
1	AMAROK WELDED ASSEMBLY	1
2	TRAILER BALL MOUNT	1
3	T PLATE M10 1.5P & WIRE W300	4
4	M10 - 1.5 x 35mm SET SCREW	4
5	WSHR FT M10 X 25.4 X 3	4
6	BOLT M14 x120 x 2.0P G10.9	2
7	WASHER FT M12 x 37 x 3mm	2
8	WASHER FLAT 1/2"x1 1/8"x1/8"	2
9	SET SCREW M12x45x1.5P GR 10.9	2
10	NUT HEX FLANGE NYLON M14-2.0	2
11	WASHER FLAT M12	4
12	WSHR SPRING FT SEC M12x4.0x2.5mm	4
13	SET SCREW M12-1.5x40 GR8.8	4
14	BOLT M10-1.50 x 25	1
15	HEX NUT M10x1.5	1

ITEM	DESCRIPTION	QTY
16	HITCH BOX COLLAR COVER	1
17	H.R STICKER	1
18	HR TOWBALL	1
19	"D" SHACKLE 10mm	2
20	CAN WIRING LOOM VW AMAROK	1
21	PULL PIN	1
22	SPRING COTTER PIN ASSY	1
23	COMPLIANCE LABEL	1
24	SUPPORT PLATE RHS	1
25	SUPPORT PLATE LHS	1
26	SCREW PAN HD M4 X 16 X 0.7P G4.6	2
27	NUT NYLON LOCK HEX HD M4X0.7P	2
28	M4 WASHER	2
29	CAN TRAILER WARNING LABEL	2



TOWBAR INSTALLATION INSTRUCTIONS

PART NUMBER 03274RW

VOLKSWAGEN AMAROK 2H CL4 UTE

WIRING ASSEMBLY DIAGRAM

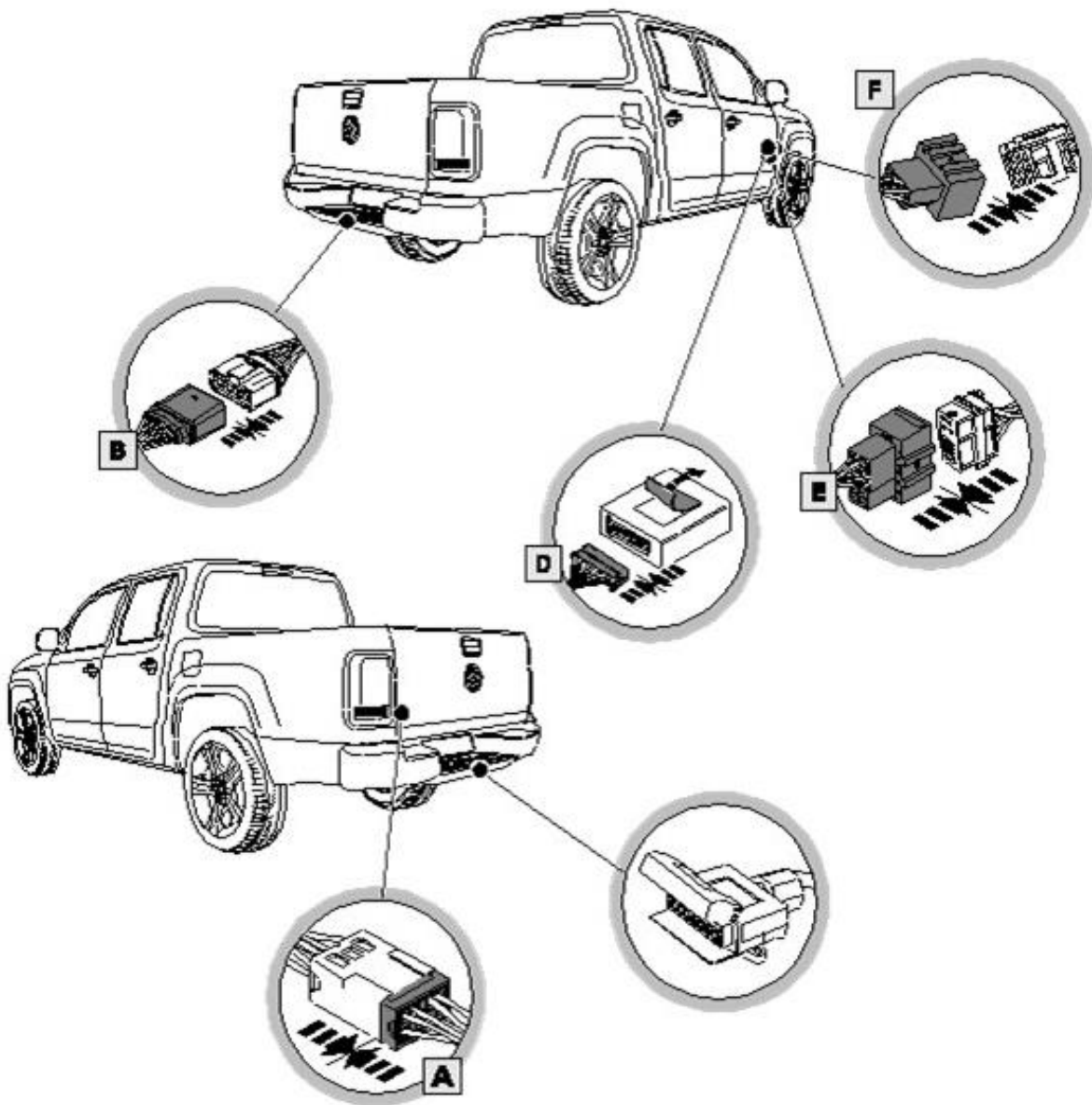



TOWBAR INSTALLATION INSTRUCTIONS

PART NUMBER 03274RW

VOLKSWAGEN AMAROK 2H CL4 UTE

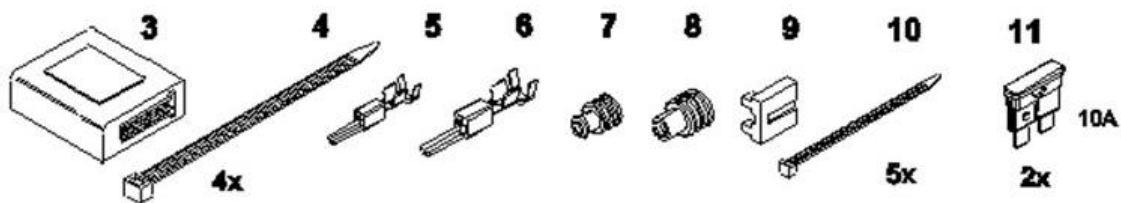
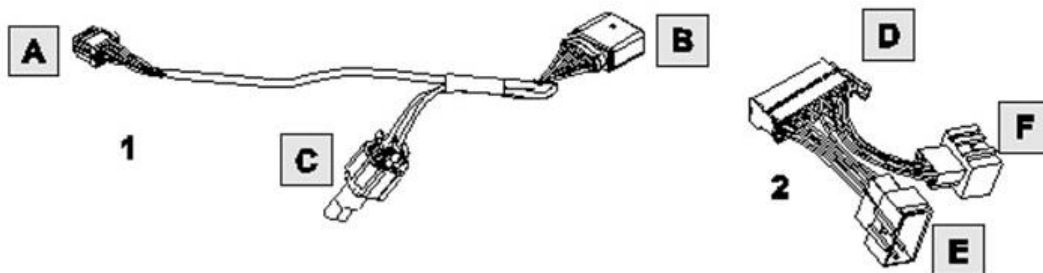

ITEM	DESCRIPTION	QTY
1	Rear outside harness	1
2	Front inside harness	1
3	Trailer module -> WLE70004	1
4	Tie Straps – 300mm long	4
5	Brake controller plug pin - small	1
6	Brake controller plug pin - large	1
7	Weather Seal brake controller plug - small	1
8	Weather Seal brake controller plug - large	1
9	Secondary lock brake controller plug	1
10	Tie straps - 150mm long	5
11	Fuse 10A - red	2



TOWBAR INSTALLATION INSTRUCTIONS

PART NUMBER 03274RW

VOLKSWAGEN AMAROK 2H CL4 UTE

TOOLS

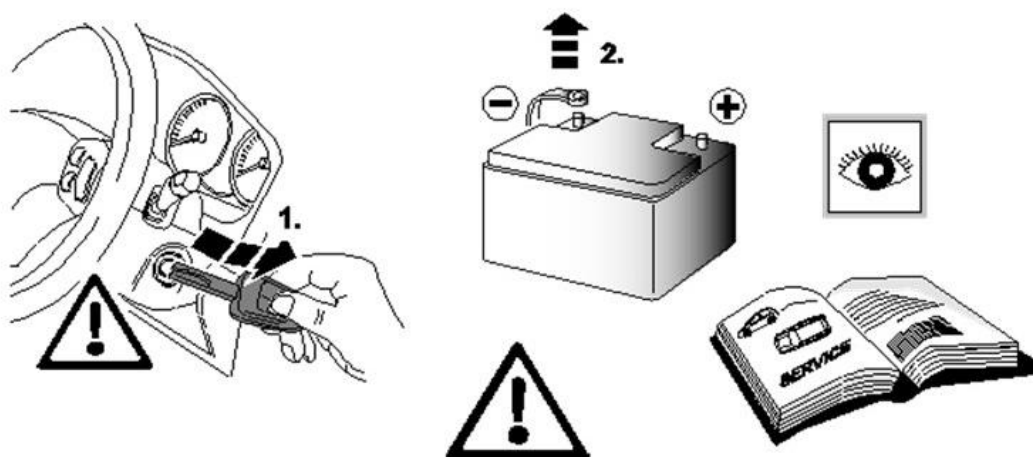
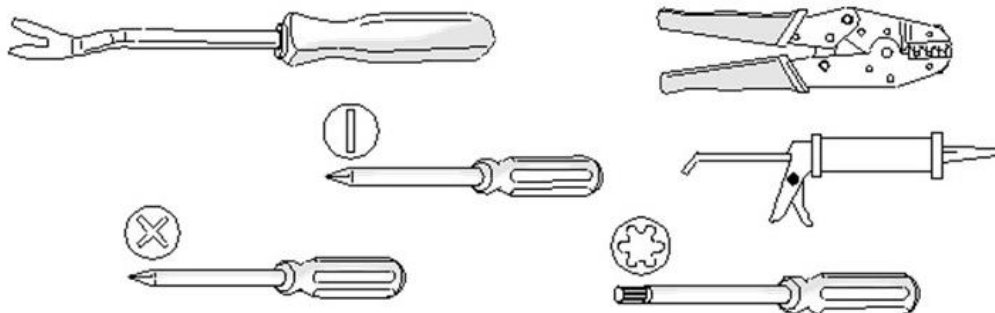



TOWBAR INSTALLATION INSTRUCTIONS

PART NUMBER 03274RW

VOLKSWAGEN AMAROK 2H CL4 UTE

1. Fit Towbar under bumper, aligning holes in mount plate with chassis.

Insert 4 off M12 x 40-1.5p Bolts, with spring Washer and flat Washer through mount plate into chassis Captive Nuts.

Torque:

M12x40x1.5P GR8.8 = 83Nm

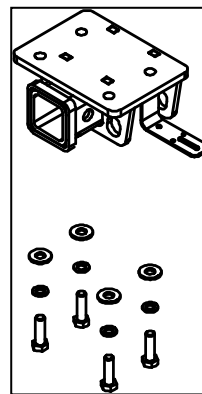

2. Carefully remove the 2 step Mounting Bolts connecting the step to the Chassis Rail, discarding the existing Bolts.

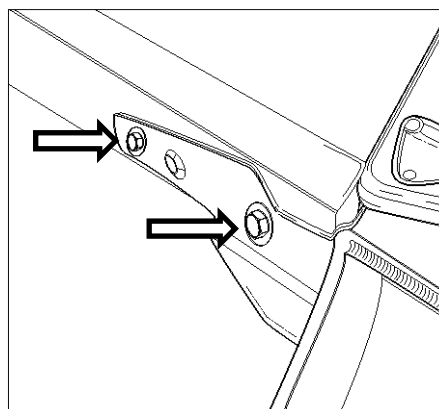

3. Bolt the step support Bracket to the step using the Bolts provided to the torque specification below, Spare wheel may need to be lowered to make room for installation of step support plates. See exploded view on page 3 for reference.

Torque:

M14x120x2.0P GR10.9 = 175Nm

M12x45x1.5P GR10.9 = 117Nm

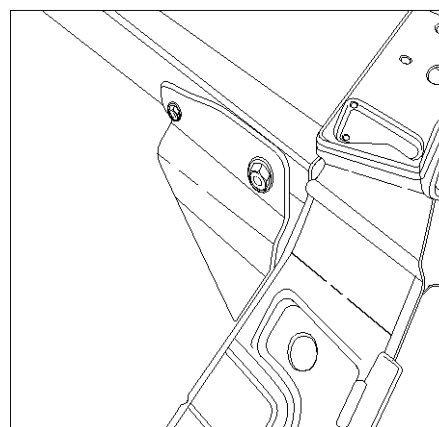



TOWBAR INSTALLATION INSTRUCTIONS

PART NUMBER 03274RW

VOLKSWAGEN AMAROK 2H CL4 UTE

4. Using the step support Bracket as a drilling template drill out the 2 holes in the bottom of the step cross, using a 11mm drill bit.

Using the existing hole in the step cross tube feed in the 2 x tapped plates and fasten the 2 x M10 Bolts to them to the torque specification below.

Torque:

M10x35x1.5P GR8.8 = 44Nm

Cut away excess wire from tapped plates.
Repeat steps 2 to 4 for other side of vehicle.

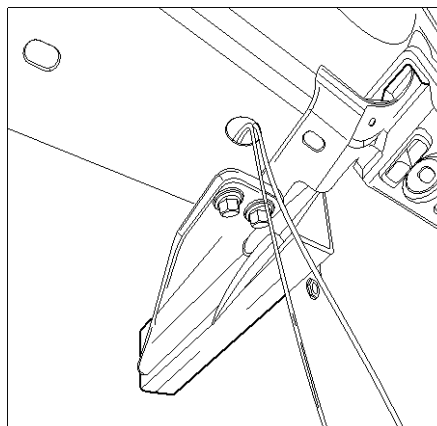

! IMPORTANT

Due to possible vehicle variations, always confirm any noted vehicle colour wires with a multi-meter to ensure the correct function is identified before soldering or scotch locking. For vehicle wires denoted with two colours (example; RED/GREEN) the first colour will always be the main wire colour while the second colour is the thinner trace colour on the wire.

5. Find the prepared 14-way trailer plug located at the rear left chassis underbody.

Unplug the blanking plug (1), discard (2).

Connect the rear outside harness (1) using connector (B).

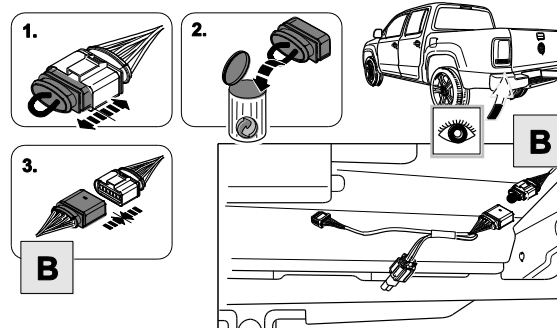



TOWBAR INSTALLATION INSTRUCTIONS

PART NUMBER 03274RW

VOLKSWAGEN AMAROK 2H CL4 UTE

6. Connect tail harness with 8-way connector to outside trailer harness connector (A).

Waterproof the trailer harness 8-way connector (A) and the tail harness 8-way male connector, using silicone or grease.

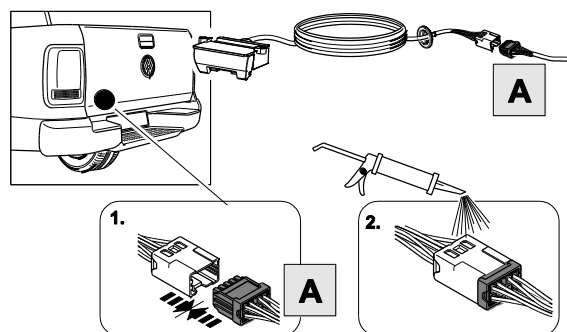

7. Route the trailer harness to the socket plate and fix the trailer harness with enclosed tie straps.

Mount the trailer socket. (AA)

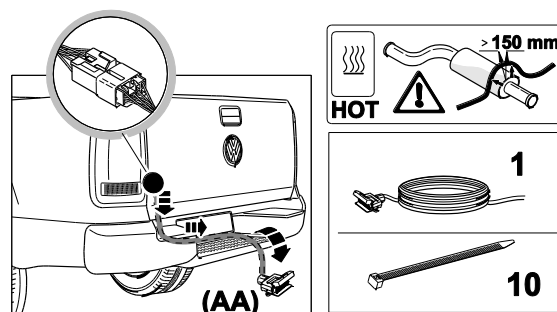

8. Remove the right front trim panels as shown.

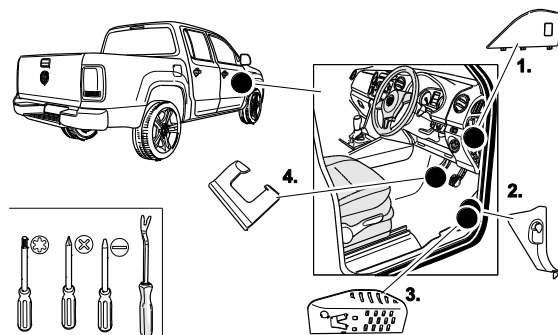



TOWBAR INSTALLATION INSTRUCTIONS

PART NUMBER 03274RW

VOLKSWAGEN AMAROK 2H CL4 UTE

9. Locate the 2 prepared connectors and remove the foam tape.

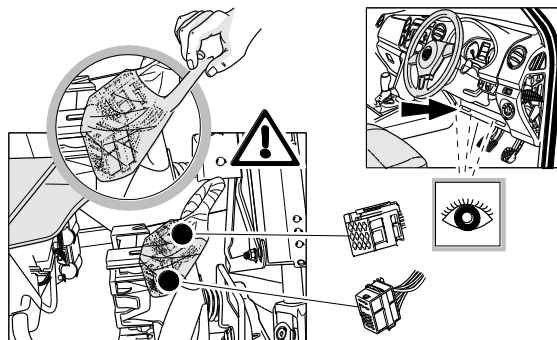

10. Connect internal harness (2) as shown.

Make sure that the connectors are fully home by hearing the connector lock.

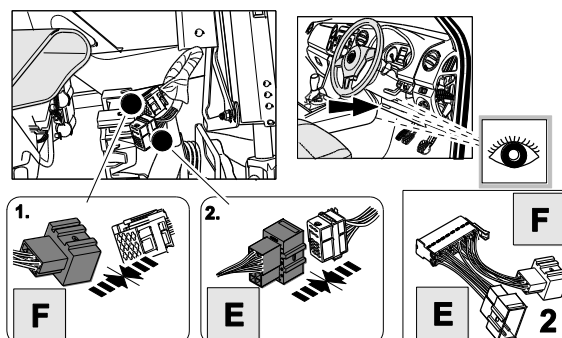

11. Connect the trailer ECU (3) using connector (D). Find a good flat clean surface, remove the backing tape from the adhesive pad and press the module against this surface. Apply pressure for 60 seconds to ensure good adhesion.

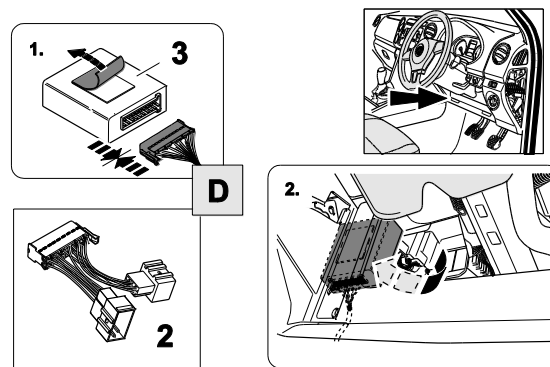



TOWBAR INSTALLATION INSTRUCTIONS

PART NUMBER 03274RW

VOLKSWAGEN AMAROK 2H CL4 UTE

12. Identify vehicle variant by VIN & action step 10 and 11 accordingly.



OPTION 1



VIN
VW1ZZZ2HZ**B**0000000

VW1ZZZ2HZ**C**0000000

13. All other production times are not affected.



OPTION 2



VIN
VW1ZZZ2HZ**D**0000000 >>

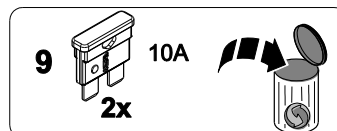

Option 1

14. If empty, place enclosed fuses 10A into fuse slot F60 and F61.

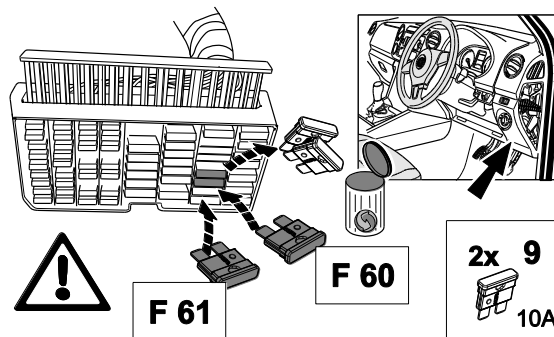



TOWBAR INSTALLATION INSTRUCTIONS

PART NUMBER 03274RW

VOLKSWAGEN AMAROK 2H CL4 UTE

Option 2

15. Enclosed fuses are not needed.

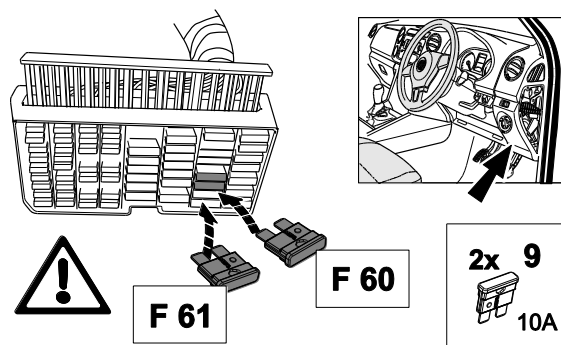

16. Re-connect the battery.

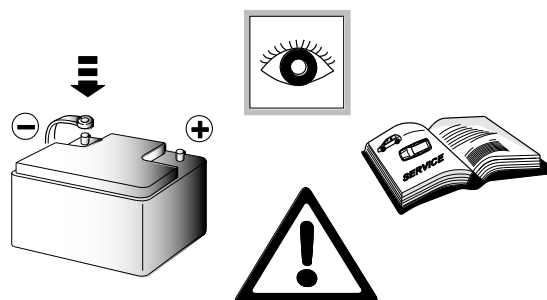

17. Next step is coding of vehicle. Pay attention to the "SmartCODE" instruction (Appendix).

18. Check all light functions.

Before testing the lights and automatic parking sensor deactivation with a tester or trailer connected, the trailer module must be activated by putting your foot on the brake.

This allows the module to detect if a trailer is connected. Once a trailer is disconnected, another press on the brake will enable the module to detect no trailer is connected.

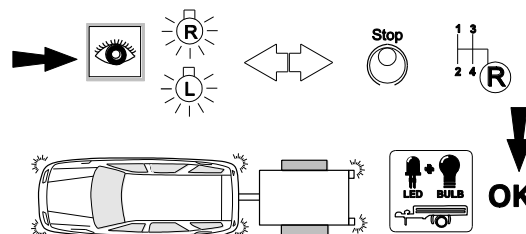



TOWBAR INSTALLATION INSTRUCTIONS

PART NUMBER 03274RW

VOLKSWAGEN AMAROK 2H CL4 UTE

19. A trailer bulb out condition is indicated with an increased indicator frequency as well as a display on the dash.

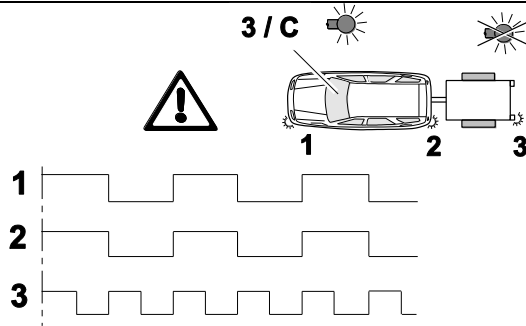

20. Place the instructions in the glove box after fitment.

21. Install brake controller plug.

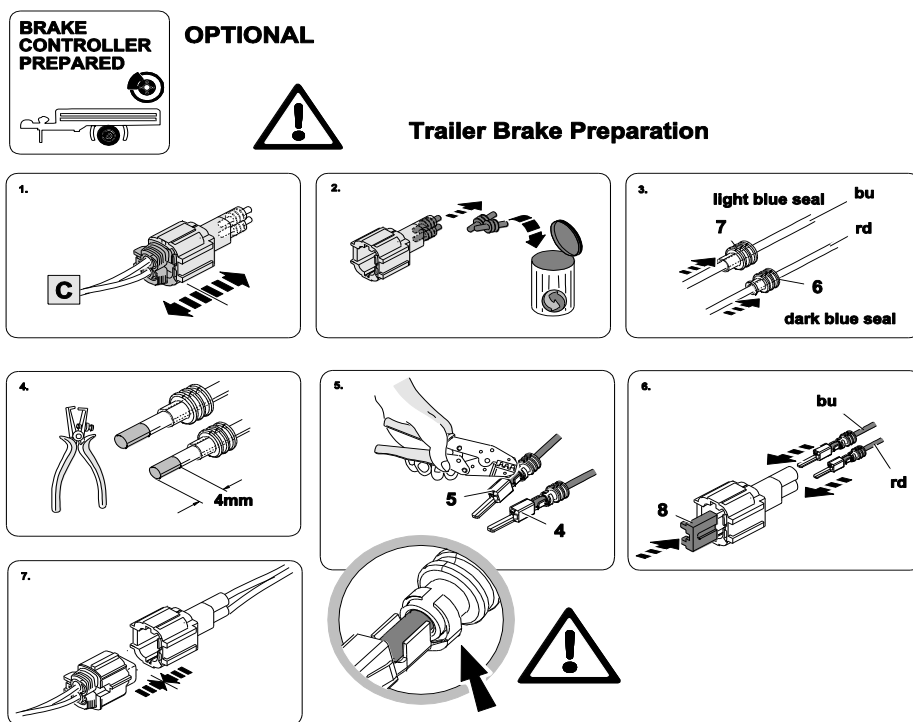



CUSTOMER INFORMATION

PLACE THESE INSTRUCTIONS IN THE VEHICLE'S GLOVEBOX AFTER INSTALLATION

**THANK YOU FOR PURCHASING HAYMAN REESE.
WITH CORRECT MAINTENANCE AND CARE THIS PRODUCT WILL PROVIDE A
LIFETIME OF TROUBLE-FREE OPERATION.**

TOWBAR MAINTENANCE AND CARE:

1. Hayman Reese recommend that the towbar LUG or TBM (tow ball Mount) Pull Pin and R-clip are removed and stored when not in use. Removal of LUG or TBM (tow ball mount) is advisable when not in use to assist with any of the following.
 - Ensure rear number plate is not obscured.
 - Allow maximum available departure angle and prevent any potential interference.
 - Prevent possible interference with vehicles reverse sensors or camera detecting a tow ball mount as an obstruction during reversing.
 - Removes towball mount as an obstruction for when moving around the rear of the vehicle.
2. Hayman Reese recommends routine inspection of your towbar to ensure trouble free towing.
 - Bolt security and tension should be regularly inspected and checked for correct tension. Replace any worn or defective parts with suitable grade & class fasteners. Inspection should be requested to coincide with vehicle major services.
3. It is the owner's responsibility to ensure towing and down ball weight capacities of the towing vehicle are not exceeded.
 - Towing and down ball weights allowable may differ according to model variations. Please refer to owner's manual or vehicle dealer to confirm exact rating for your vehicle model variant.
 - It is not uncommon for the vehicle tow rating to differ from the towbar rating. When this occurs, the lesser rating must be adhered to.
 - For vehicles fitted with enhanced vehicle functions that may be altered/changed when towing i.e Trailer sway mitigation, blind spot detection, adaptive cruise control etc. Please consult owner's manual to understand changes enabled when towing and after towing.



WARRANTY INFORMATION:

Hayman Reese Towbars are covered by a Lifetime Warranty.

Our goods come with guarantees that cannot be excluded under the Australian Consumer Law. You are entitled to a replacement or refund for a major failure and for compensation for any other reasonably foreseeable loss or damage. You are also entitled to have the goods repaired or replaced if the goods fail to be of acceptable quality and the failure does not amount to a major failure.

For further details please visit www.haymanreese.com.au/warranty or contact customer service on 1800 812 017 or info@haymanreese.com.au.



CUSTOMER INFORMATION

PLACE THESE INSTRUCTIONS IN THE VEHICLE'S GLOVEBOX AFTER INSTALLATION

HAYMAN REESE SMART PIN

Your Hayman Reese towbar is equipped with Smart Pin technology to help reduce towbar tongue rattle in most driving conditions. Please ensure below instructions are understood and routine maintenance is carried out to ensure best towing experience.

i Regularly inspect for wear and check the tightness of the Smart Pin Nut. Follow instructions below to re-tighten the nut as necessary when movement and noise in the tow ball mount is noted.

- Before towing, ensure R-Clip is properly installed and Smart pin nut is installed and tensioned. Replacement parts are available from your Hayman Reese Distributor.

TOWBALL MOUNT REMOVAL/INSTALLATION

STEP 1

Insert Trailer Ball Mount (TBM) (a) into towbar hitchbox (b), aligning hole in TBM shank (c) with hole in hitchbox (d) (Fig. 1)

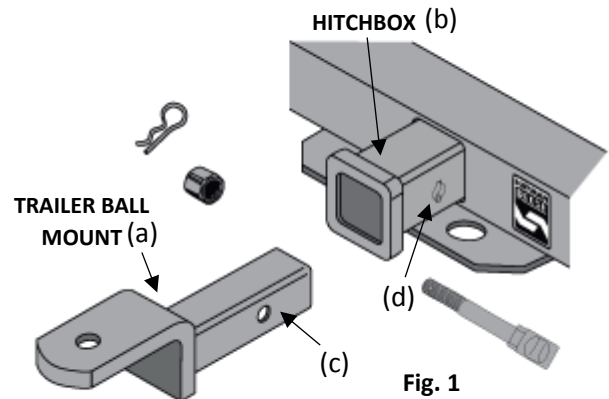

STEP 2

Insert Smart Pin (e) through hole in hitchbox and hole in TBM shank (g); ensure the locators are inserted into the notches in the hitchbox (Fig. 2)

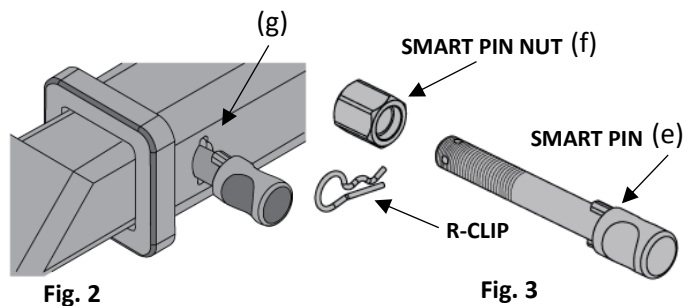

STEP 3

Screw Smart Pin Nut (f) onto Smart Pin (g); tighten Smart Pin Nut until finger tight, ensuring TBM is restrained from up and down movement.

STEP 4

Tighten Smart Pin Nut by turning nut a further 1/8th of a turn in the clockwise direction using a 24mm spanner (Fig. 4).

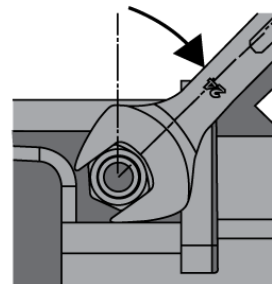

STEP 5

Install Smart Pin R-Clip through the hole that provides best clearance or easiest access. (Fig. 5)

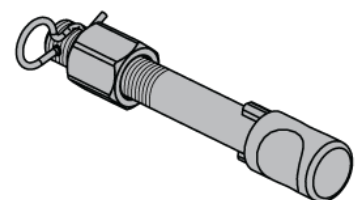

Appendix



WARNING: This vehicle requires a system setting to ensure the trailer wiring and control module are correctly recognised. This process (referred to as 'coding') must be carried out to enable correct vehicle functionality when trailer is connected. Towing features enabled by correct control module and coding support OE functionality as set by OE manufacturer. Please read the vehicles owner's manual for proper operation and understanding.

Coding can be carried out using the Hayman Reese SmartCODE (HRSC) using the following steps. Note, if HRSC is unavailable, vehicle coding can be carried out by OE manufacturer as needed.

Before you start:

- **Ensure the HRSC software is up to date using the HAYMAN REESE SMARTCODE PC APP.**
 - **Ensure the vehicle battery is fully charged**
 - **Use of a battery support unit (BSU) is advised during the coding process.**
 - **Ensure towbar, wiring loom and ECU are correctly installed as per Hayman Reese fitting instructions.**
1. Locate the OBD2 port under the drivers footwell on the right-hand side and plug in the HRSC.
 2. Close all doors and turn the ignition on
 3. Follow the directions on the screen of the HRSC
 4. Once the vehicle has been coded successfully proceed to the "clear codes" tab
 5. Remove disconnect HRSC from OBD2 port.
 6. Check the dash to make sure there are no warning faults.
 7. Check the operation of trailer lights and ensure the Reverse Park Assist (RPA) is disabled and 'trailer on' icon is active where available.

For technical support and further information on Hayman Reese SmartCODE tool and coding process contact your nearest Hayman Reese stockist.

Australia: 1800 812 017

New Zealand: 0800 237 886