



TOWBAR INSTALLATION INSTRUCTIONS

PART NUMBER 03280RW

JAGUAR F-PACE X761 CL4



PRODUCT DETAILS:

Part Number:	03280RW	Maximum Towing Braked:	2400	kg
ECU Number:	WLE70010	Maximum Towing Unbraked:	750	kg
Tail Harness Length Required:	1200 mm	Maximum Static Ball Load:	240	kg
TBM/Lug Part Number:	21325			
Wiring Part No.	WLL90010			

FITTING DETAILS:

Towbar Installation Time:	80 Mins.	Hayman Reese SmartCODE Solution Required:	NO
Wiring Installation Time:	45 Mins.	RPA Disable/Other:	YES
Total Installation Time:	125 Mins.	Note:	
Bumper Cut Required:	Yes		

- RPA Accessory disable when vehicle is coded
- Electric Brake = Brake Prep Connector



TOWBAR INSTALLATION INSTRUCTIONS

PART NUMBER 03280RW
JAGUAR F-PACE X761 CL4

ENSURE THAT INSTRUCTIONS ARE UNDERSTOOD PRIOR TO FITMENT.

i BEFORE YOU START:

Hayman Reese recommends that instructions are read completely prior to fitment. Check all hardware items have been included refer to assembly diagram. Please ensure this towbar is only fitted to vehicle models as per Hayman Reese application guide (www.haymanreese.com.au).

Bumper Cuts



Vehicle and bumper variations can and do occur during vehicle manufacture after initial towbar design. Fitment of towbar to vehicle and accuracy of bumper cut must be assessed prior to any bumper modifications made. Incorrect bumper cuts are not covered under Hayman Reese warranty.

NOTE: Bumper cuts need to be approached with care, refer to notes below.

- Bumper centreline – where the centreline of the bumper needs to be determined, the installer must assess centre point by measurement of bumper width or determining two symmetrical reference points to give centreline.
- Bumper edge – To assist with accurate bumper cut measurement, reference to the start of the bumper edge is now being commonly used.
 - Measure from bottom edge along bumper and around corner to the 70 mm point (Figure 1).
 - Do not measure from visible bumper front of corner, upwards (Figure 2).

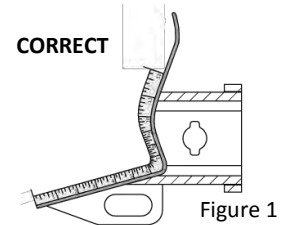

Figure 1

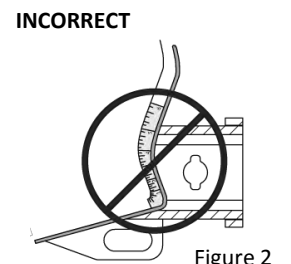

Figure 2

Drilling

- For any required drilling during installation, ensure that the area is clear of fuel, electrical & other components that may be damaged.
- All holes drilled into the body panels shall have all burrs & swarf removed then coated with a suitable rust preventative paint.

Bolts/Fasteners

- Ensure that all hardware is fastened to correct torque as specified in this fitting instruction.
- All fasteners supplied with this product are used to achieve a specified clamp loading. If replacement is required ensure that fasteners of the same grade and class are used.



NOTE: Achieving correct torque is critical to proper installation and responsibility of the installer. Towbar failures attributed to tension issues from over tightening or under tightening are not covered by Hayman Reese warranty.

Product Labels

- Towbar load rating sticker provided with this product shall be conspicuously located on inside rear end of the driver's door.
- Powertrain Control Module (PCM)/Body Control Module (BCM) upgrade warning label will be provided in towbar kit for vehicles as required. Affix warning label in door and owner's handbook.

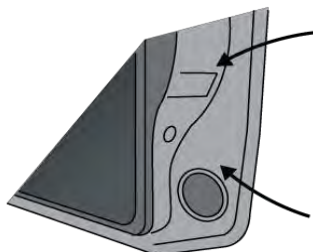

Place **Load Rating sticker** inside driver's door here

Place **Vehicle PCM/ BCM upgrade warning label** in door AND on front cover of owner's service handbook



WARNING:

Do not, drill, cut, weld or otherwise modify the towbar.

FOR TOWING PURPOSES ONLY - This towbar is designed and tested by Hayman Reese to adhere to ADR 62/02 which provides only for the expected load demands of towing.



TOWBAR INSTALLATION INSTRUCTIONS

PART NUMBER 03280RW
JAGUAR F-PACE X761 CL4

i TOWBAR ASSEMBLY DIAGRAM

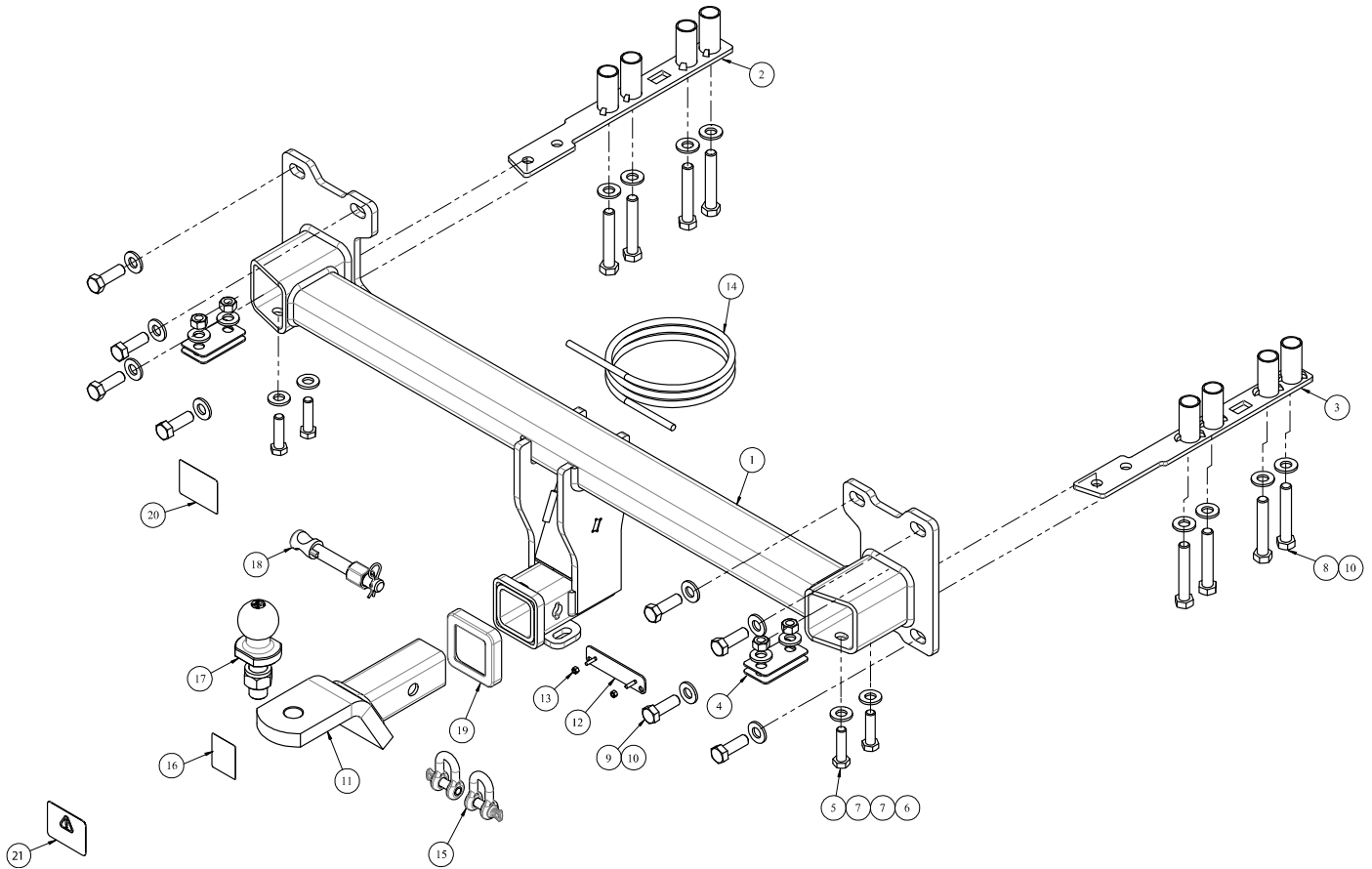

ITEM	DESCRIPTION	QTY
1	JAGUAR F-PACE WELDED ASSY	1
2	SIDE ARM ASSY LH	1
3	SIDE ARM ASSY RH	1
4	SPACER	4
5	SET SCREW M12 - 1.25 x 45mm GR 8.8	4
6	NUT HEX HD M12 X 1.25P G8	4
7	WASHER PLAIN 1/2X1-1/8X16G	8
8	BOLT HEX HD M14X80X2.0P GR8.8	8
9	BOLT M14-2.0Px40 GR 8.8	8
10	M14 X 28 X 3 Z/P FT WASHER	16
11	TRAILDER BALL MOUNT	1

ITEM	DESCRIPTION	QTY
12	PLUG BRACKET	1
13	NUT NYLON LOCK HEX HD M4X0.7P	2
14	WIRING LOOM	1
15	10mm "D" SHACKLE	2
16	H.R STICKER	1
17	TOWBALL 50MM FLAT CHROME	1
18	SMART PIN ASSY CLASS 4 - GOLD	1
19	HITCH BOX COLLAR COVER	1
20	ACRYLIC COMPLIANCE LABEL	1
21	CAN TRAILER WARNING LABEL	2



TOWBAR INSTALLATION INSTRUCTIONS

PART NUMBER 03280RW
JAGUAR F-PACE X761 CL4

i WIRING ASSEMBLY DIAGRAM

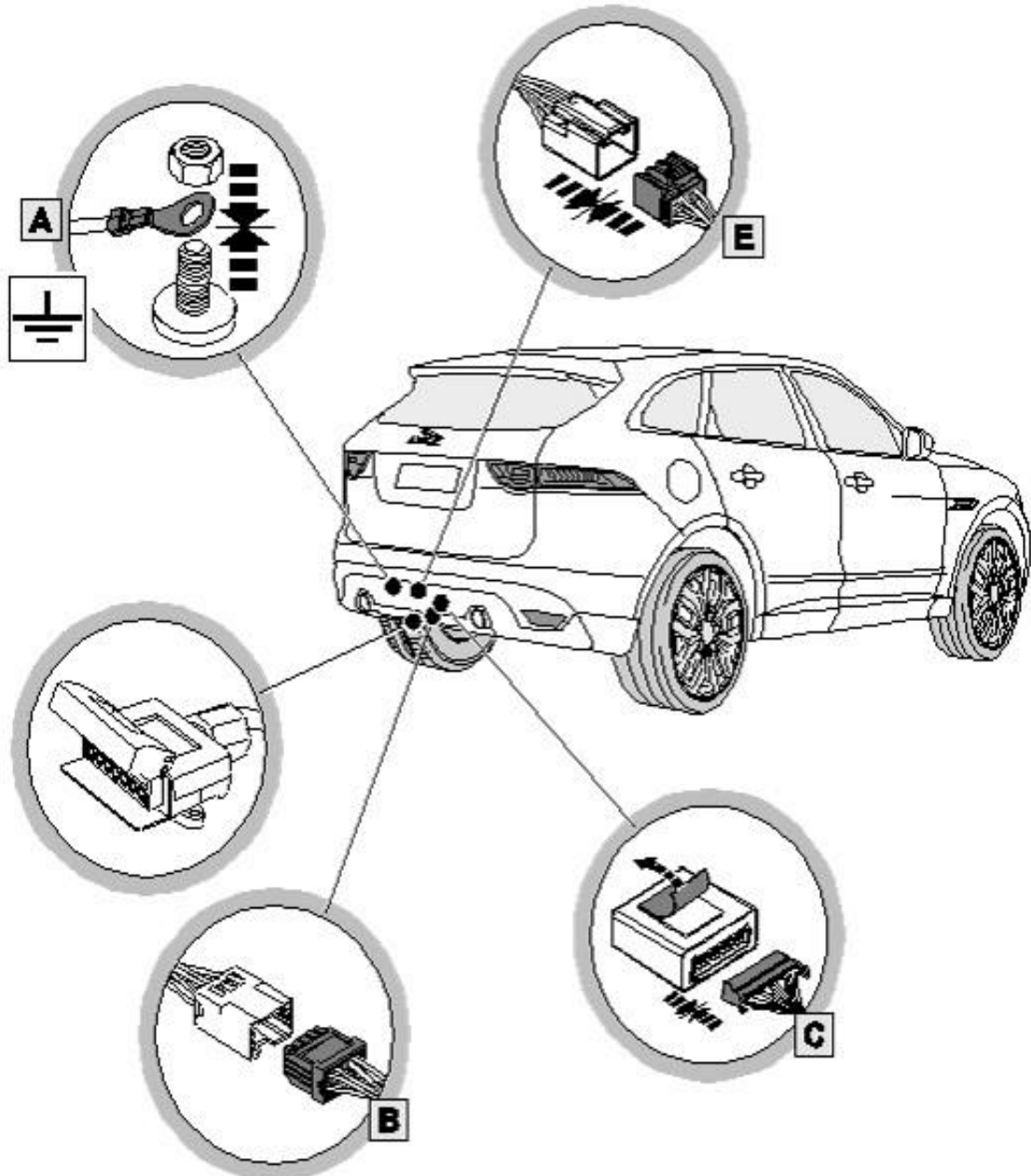



TOWBAR INSTALLATION INSTRUCTIONS

PART NUMBER 03280RW

JAGUAR F-PACE X761 CL4

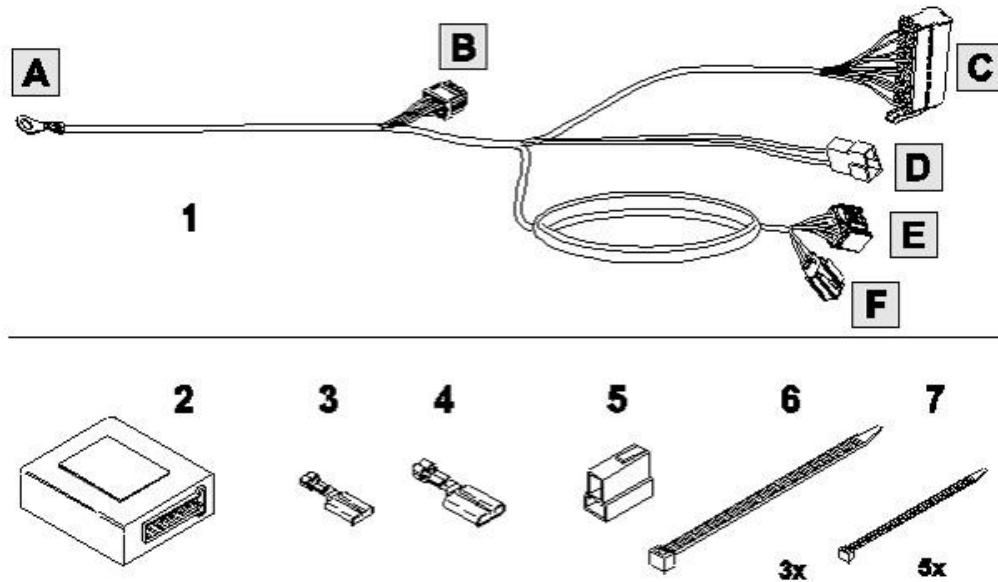

ITEM	DESCRIPTION	QTY
1	Trailer patch harness	1
2	Trailer module → WLE70010	1
3	Brake controller plug pin - small	1
4	Brake controller plug pin - large	1
5	Brake controller 2-pin housing	1
6	300mm Cable tie	3
7	150mm Cable tie	5

TOOLS

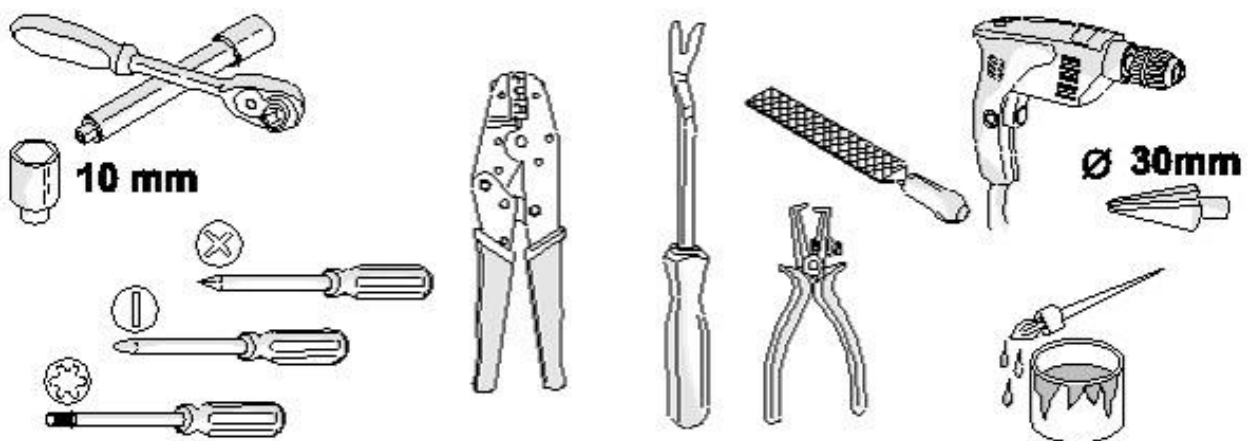



TOWBAR INSTALLATION INSTRUCTIONS

PART NUMBER 03280RW

JAGUAR F-PACE X761 CL4

1.

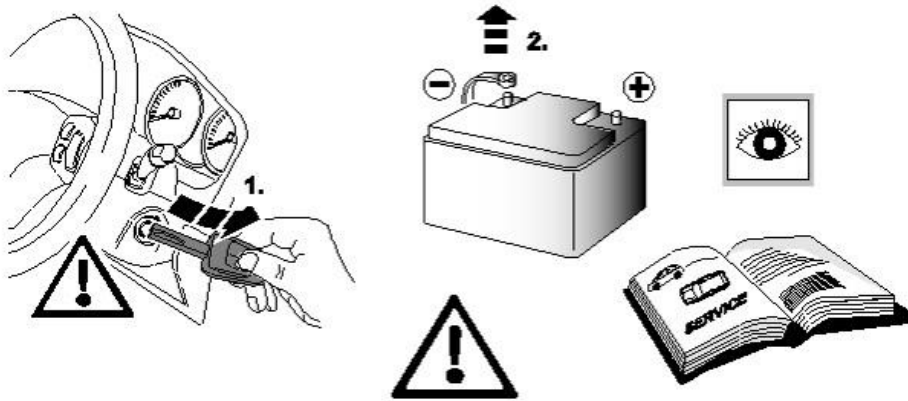

2. Open tailgate and remove plastic trim cover.
(arrows indicate approximate clip positions)

Repeat for other side.

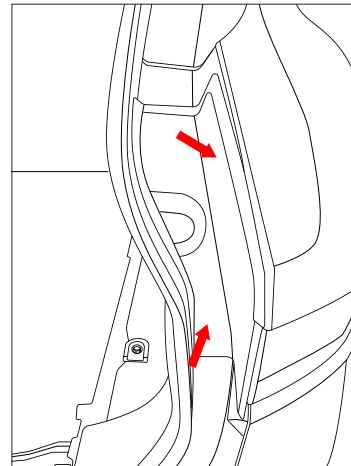

3. Remove the exposed 1 x bolt and 1 x plastic screw on
the bumper.

Repeat for other side.

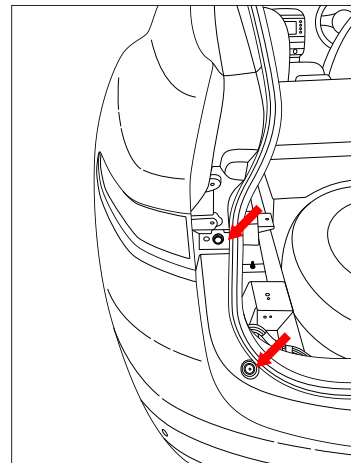



TOWBAR INSTALLATION INSTRUCTIONS

PART NUMBER 03280RW

JAGUAR F-PACE X761 CL4

-
- In wheel arch remove 2 x screws.
 - Peel back the wheel arch trim and remove exposed 2 x torx screws and 4 x screws.

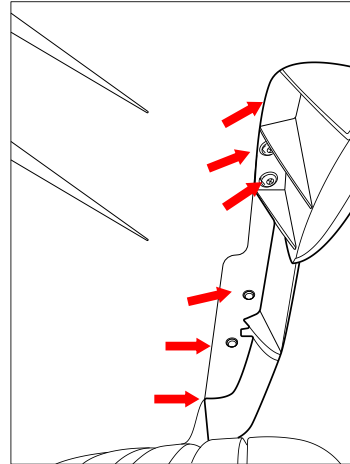

-
- Under vehicle remove lower garnish secured with 4 x screws and 3 x bolts.

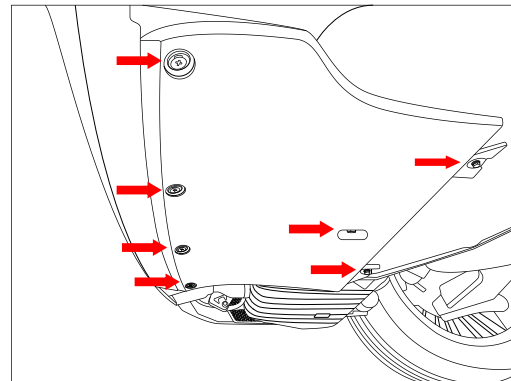

-
- Peel away bumper from sides and remove from vehicle. Ensure to disconnect the supporting electrical connectors, located on the LHS.



TOWBAR INSTALLATION INSTRUCTIONS

PART NUMBER 03280RW

JAGUAR F-PACE X761 CL4

8. Remove the 3 x exhaust rubber mounts to lower the rear muffler. Support rear muffler with straps if required.

9. Remove the exhaust heat shield secured with 3 x bolts.

Repeat for other side if vehicle has a dual exhaust system.

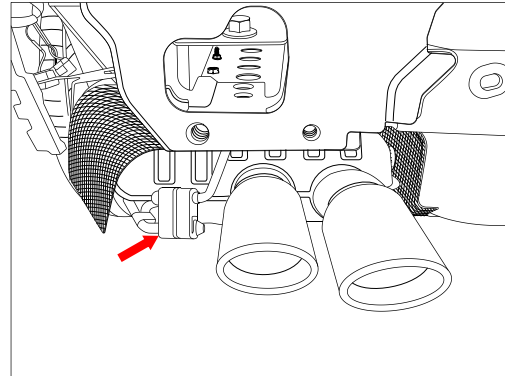

10. Remove the impact beam secured with 4 x bolts per side and discard.

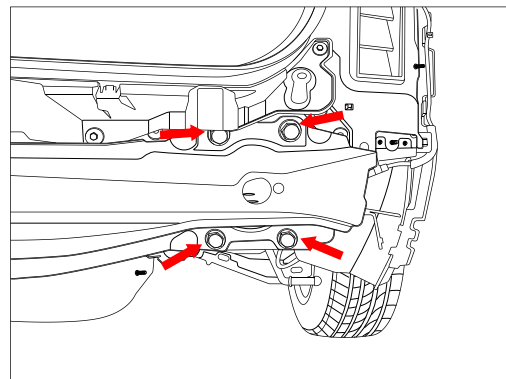

11. Insert the LH Side arm assembly into the chassis rail and loosely secure from under the chassis rail with 4 x M14 x 80 bolts complete with 1 x washer per bolt.

Repeat for other side.

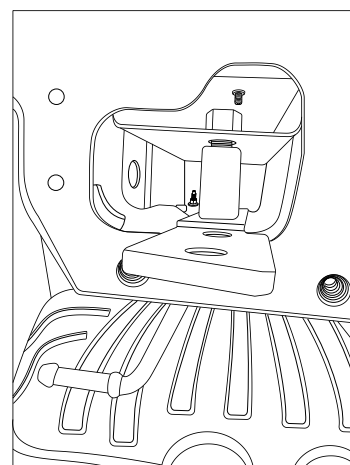



TOWBAR INSTALLATION INSTRUCTIONS

PART NUMBER 03280RW

JAGUAR F-PACE X761 CL4

12. Lift crosstube up to vehicle and loosely secure to the vehicle rear panel with 8 x M14 x 40 Bolts complete with 1 x washer per bolt. (4 per side)
13. Add supplied spacer plates between the Crosstube's side arms and the Side Arm Assembly as required to minimise any gap.
14. Loosely secure the Side arm assembly to the crosstube's side arm with 2 x M12 x 45 complete with 2 x washers and 1 x M12 nut per bolt.

Repeat for other side.

15. Position the towbar and torque all bolts (including under chassis rail) as specified:

M12 GR8.8 : 89Nm

M14 GR8.8 : 124Nm

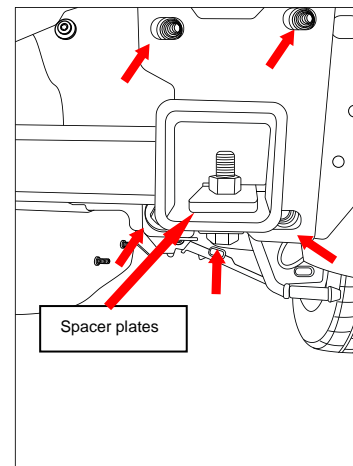

16. On the Lower garnish (removed in step 5) determine the centre, measure, mark and cut out a recess 100mm x 100mm measured from the edge of the garnish.

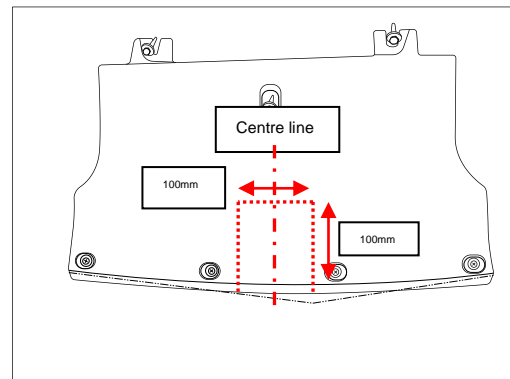

17. On the lower garnish, find a suitable location for the plug bracket. Mark out and drill 2x ø5mm holes 69mm apart on the skin to support plug bracket.

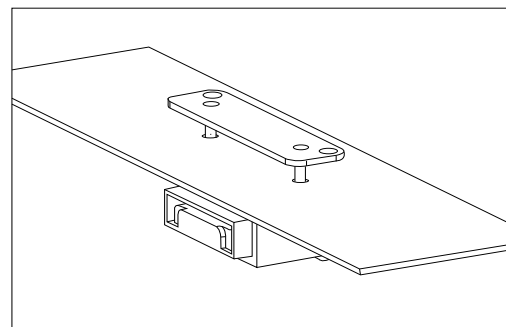



TOWBAR INSTALLATION INSTRUCTIONS

PART NUMBER 03280RW

JAGUAR F-PACE X761 CL4

IMPORTANT

Due to possible vehicle variations, always confirm any noted vehicle colour wires with a multi-meter to ensure the correct function is identified before soldering or scotch locking. For vehicle wires denoted with two colours (example; RED/GREEN) the first colour will always be the main wire colour while the second colour is the thinner trace colour on the wire.

18. Ensure negative cable is disconnected from the battery terminal.

19. Open the boot and remove the keys from the vehicle.

20. Remove the rear parcel shelf.

21. Remove the boot floor carpet.

22. Remove the rear boot sill trim by removing 2x 10mm nuts dislodge the trim and disconnect the wire clip on the RHS and remove.

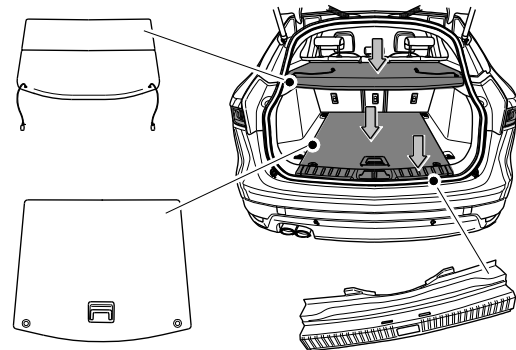

24. On the LHS remove the 2x cargo hooks.

25. Remove 3x scrivet down the bottom.

26. Remove 2x scrivet, the upper trim screw.

27. Remove the 2x net holders.

28. Dislodge and upper trim and disconnect the boot light.

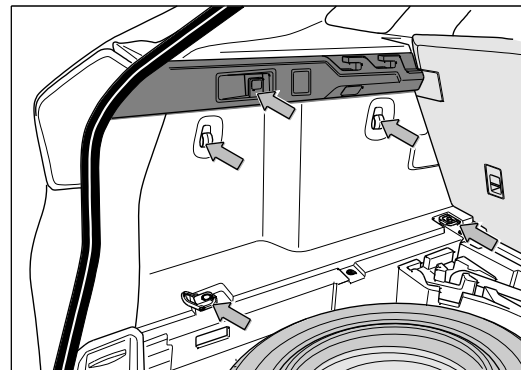



TOWBAR INSTALLATION INSTRUCTIONS

PART NUMBER 03280RW

JAGUAR F-PACE X761 CL4

29. Remove the 3x scrivet and remove the LHS trim.

30. Remove the spare wheel.

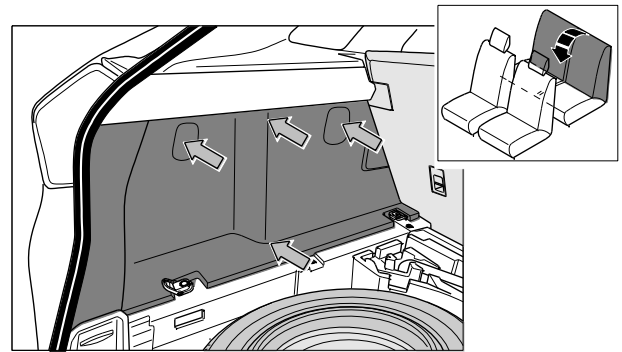

31. Remove the blanking grommet on the RHS of the rear and drill the hole out to $\varnothing 30\text{mm}$.

32. Remove all sharp edges and spray rust inhibitor.

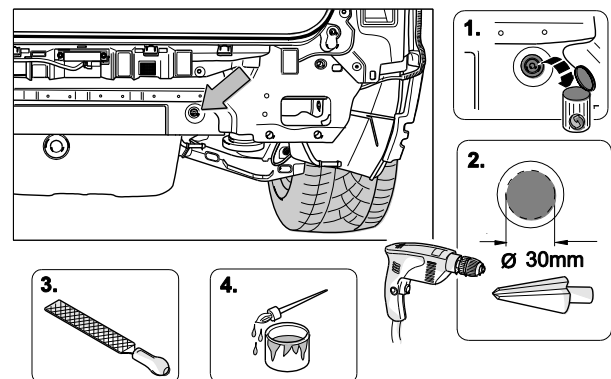

33. From outside the vehicle feed the tail harness (1200) through the previously drilled hole, slide the grommet to the required length, and secure the grommet with a supplied cable tie. Ensure the grommet is seated properly.

34. Place the trailer patch harness (1) inside the vehicle, locate the 8-way tail harness connector and connect it to the 8-way female connector on the trailer patch location (B).

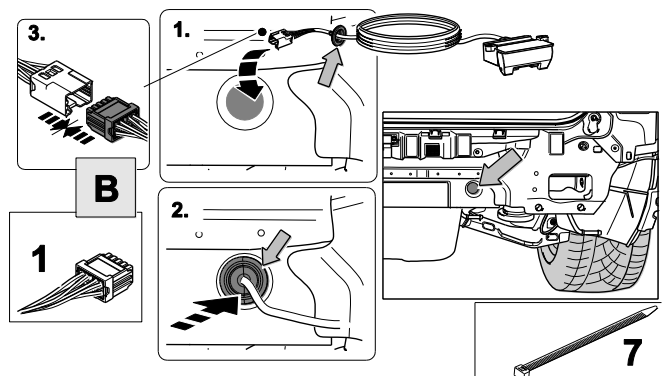



TOWBAR INSTALLATION INSTRUCTIONS

PART NUMBER 03280RW

JAGUAR F-PACE X761 CL4

35. Route the trailer harness to the socket plate and fix the trailer harness with enclosed tie straps.

Mount the trailer socket.

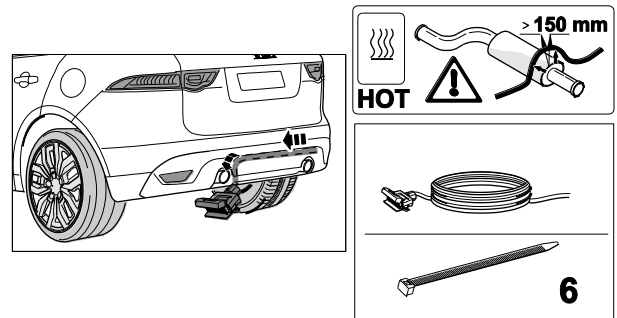

36. Plug the ECU item (2) into the trailer patch item (1) location (C).

37. Peel the backing of the adhesive tape from the rear of the ECU and mount the ECU in the location shown.

Ensure the tape has good adhesion.

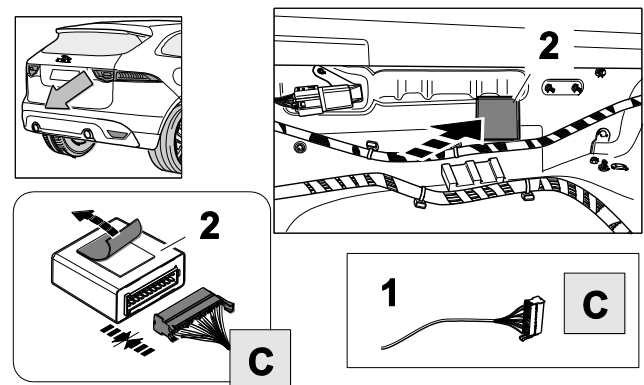

38. Connect the ring terminal location (A) to the factory Ground stud.

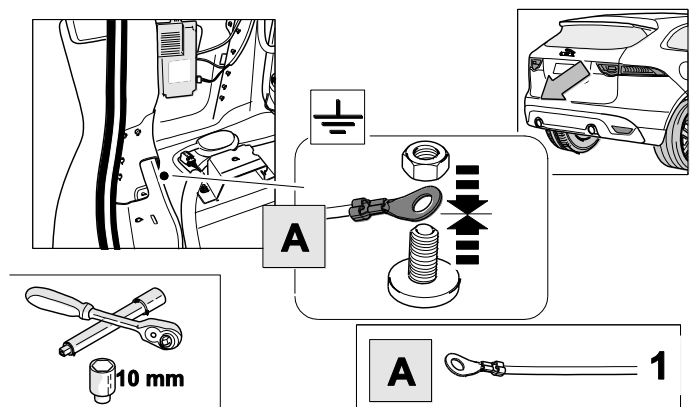



TOWBAR INSTALLATION INSTRUCTIONS

PART NUMBER 03280RW
JAGUAR F-PACE X761 CL4

39. Locate the 8-way trailer break out connector and remove the blanking plug on the LHS rear.
40. Route the trailer patch harness towards the LHS along the vehicle main harness.
41. Plug the trailer patch harness location (E) 8-way CAN/BATT connector into the trailer break out connector.

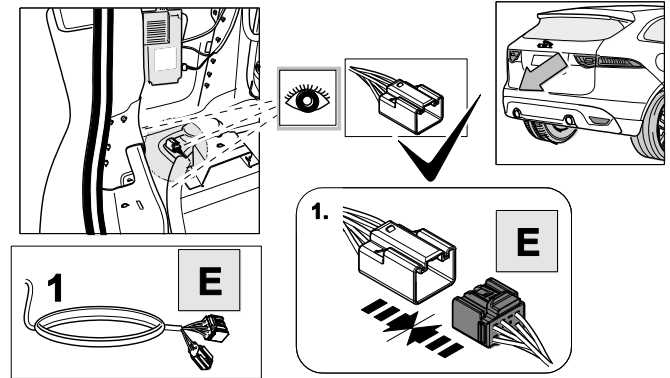

42. Re-connect the battery.

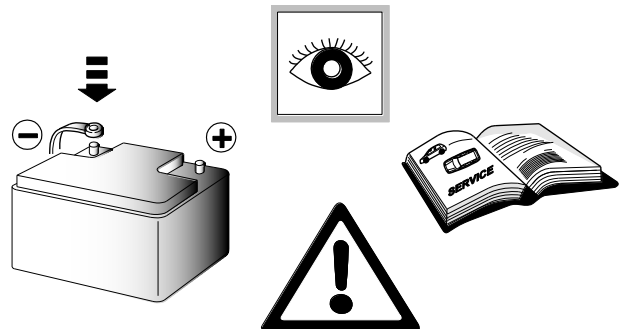

43. Check all light functions.

Before testing the lights with a tester or trailer connected, the trailer module must be activated by putting your foot on the brake.

This allows the module to detect if a trailer is connected. Once a trailer is disconnected, another press on the brake will enable the module to detect no trailer is connected.

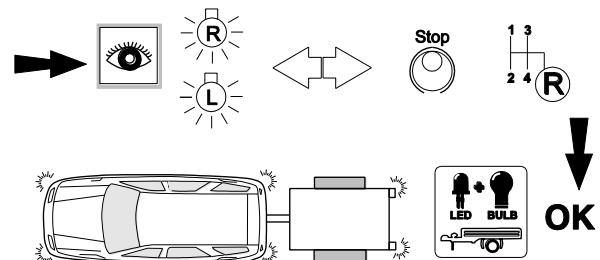



TOWBAR INSTALLATION INSTRUCTIONS

PART NUMBER 03280RW

JAGUAR F-PACE X761 CL4

44. A trailer bulb out condition is indicated with an increased indicator frequency as well as a display on the dash.

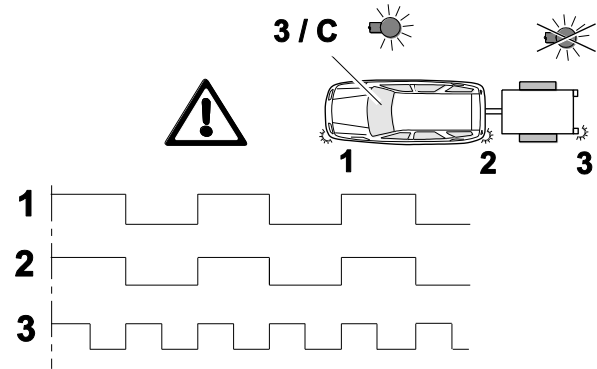

45.



Trailer Brake Preparation

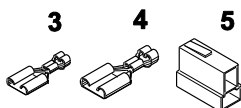
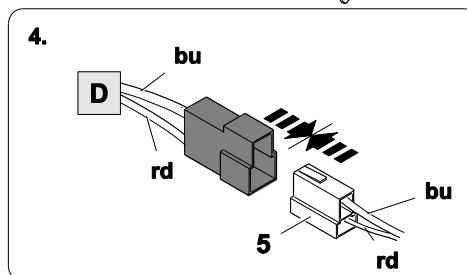
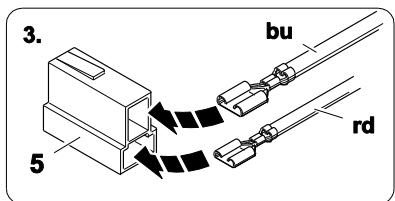
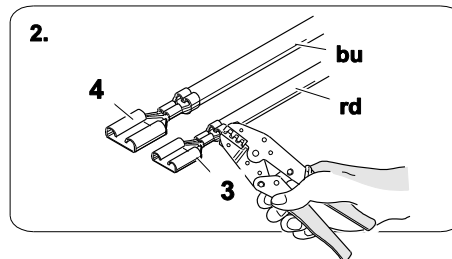
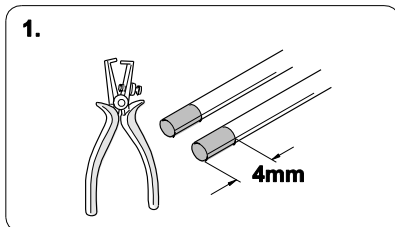
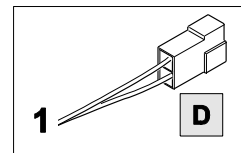

46. Refit all removed parts, excluding the impact beam.



CUSTOMER INFORMATION

PLACE THESE INSTRUCTIONS IN THE VEHICLE'S GLOVEBOX AFTER INSTALLATION

**THANK YOU FOR PURCHASING HAYMAN REESE.
WITH CORRECT MAINTENANCE AND CARE THIS PRODUCT WILL PROVIDE A
LIFETIME OF TROUBLE-FREE OPERATION.**

TOWBAR MAINTENANCE AND CARE:

1. Hayman Reese recommend that the towbar LUG or TBM (tow ball Mount) Pull Pin and R-clip are removed and stored when not in use. Removal of LUG or TBM (tow ball mount) is advisable when not in use to assist with any of the following.
 - Ensure rear number plate is not obscured.
 - Allow maximum available departure angle and prevent any potential interference.
 - Prevent possible interference with vehicles reverse sensors or camera detecting a tow ball mount as an obstruction during reversing.
 - Removes towball mount as an obstruction for when moving around the rear of the vehicle.
2. Hayman Reese recommends routine inspection of your towbar to ensure trouble free towing.
 - Bolt security and tension should be regularly inspected and checked for correct tension. Replace any worn or defective parts with suitable grade & class fasteners. Inspection should be requested to coincide with vehicle major services.
3. It is the owner's responsibility to ensure towing and down ball weight capacities of the towing vehicle are not exceeded.
 - Towing and down ball weights allowable may differ according to model variations. Please refer to owner's manual or vehicle dealer to confirm exact rating for your vehicle model variant.
 - It is not uncommon for the vehicle tow rating to differ from the towbar rating. When this occurs, the lesser rating must be adhered to.
 - For vehicles fitted with enhanced vehicle functions that may be altered/changed when towing i.e Trailer sway mitigation, blind spot detection, adaptive cruise control etc. Please consult owner's manual to understand changes enabled when towing and after towing.



WARRANTY INFORMATION:

Hayman Reese Towbars are covered by a Lifetime Warranty.

Our goods come with guarantees that cannot be excluded under the Australian Consumer Law. You are entitled to a replacement or refund for a major failure and for compensation for any other reasonably foreseeable loss or damage. You are also entitled to have the goods repaired or replaced if the goods fail to be of acceptable quality and the failure does not amount to a major failure.

For further details please visit www.haymanreese.com.au/warranty or contact customer service on 1800 812 017 or info@haymanreese.com.au.



CUSTOMER INFORMATION

PLACE THESE INSTRUCTIONS IN THE VEHICLE'S GLOVEBOX AFTER INSTALLATION

HAYMAN REESE SMART PIN

Your Hayman Reese towbar is equipped with Smart Pin technology to help reduce towbar tongue rattle in most driving conditions. Please ensure below instructions are understood and routine maintenance is carried out to ensure best towing experience.

i Regularly inspect for wear and check the tightness of the Smart Pin Nut. Follow instructions below to re-tighten the nut as necessary when movement and noise in the tow ball mount is noted.

- Before towing, ensure R-Clip is properly installed and Smart pin nut is installed and tensioned. Replacement parts are available from your Hayman Reese Distributor.

TOWBALL MOUNT REMOVAL/INSTALLATION

STEP 1

Insert Trailer Ball Mount (TBM) (a) into towbar hitchbox (b), aligning hole in TBM shank (c) with hole in hitchbox (d) (Fig. 1)

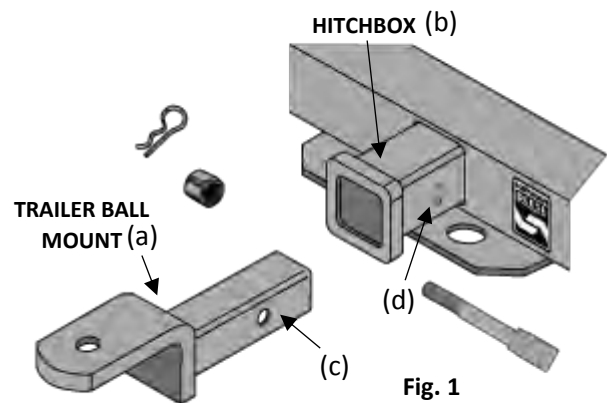

STEP 2

Insert Smart Pin (e) through hole in hitchbox and hole in TBM shank (g); ensure the locators are inserted into the notches in the hitchbox (Fig. 2)

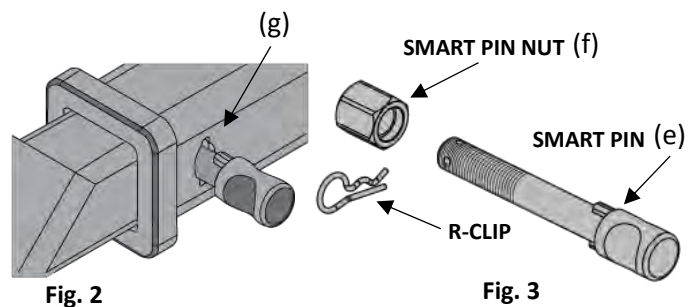

STEP 3

Screw Smart Pin Nut (f) onto Smart Pin (g); tighten Smart Pin Nut until finger tight, ensuring TBM is restrained from up and down movement.

STEP 4

Tighten Smart Pin Nut by turning nut a further 1/8th of a turn in the clockwise direction using a 24mm spanner (Fig. 4).

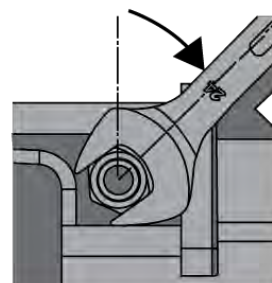

Fig. 4

STEP 5

Install Smart Pin R-Clip through the hole that provides best clearance or easiest access. (Fig. 5)

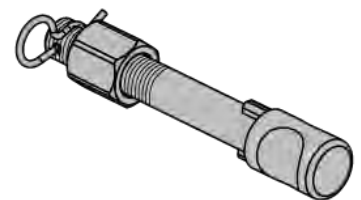

Fig. 5