



TOWBAR INSTALLATION INSTRUCTIONS

PART NUMBER 03282RW

LDV D90



PRODUCT DETAILS:

Part Number:	03282RW	Maximum Towing Braked:	2000	kg
ECU Number:	04826	Maximum Towing Unbraked:	750	kg
Tail Harness Length Required:	1200 mm.	Maximum Static Ball Load:	200	kg
TBM/Lug Part Number:	21325			

FITTING DETAILS:

Towbar Installation Time:	30 Mins.	Vehicle Coding Required:	NO
Wiring Installation Time:	50 Mins.	RPA Disable/Other:	YES
Total Installation Time:	80 mins.	Note:	
Bumper Cut Required:	No		

- Use Tail Part Number to automatically disable RPA where fitted.



TOWBAR INSTALLATION INSTRUCTIONS

PART NUMBER 03282RW

LDV D90

ENSURE THAT INSTRUCTIONS ARE UNDERSTOOD PRIOR TO FITMENT.

i BEFORE YOU START:

Hayman Reese recommends that instructions are read completely prior to fitment. Check all hardware items have been included refer to assembly diagram. Please ensure this towbar is only fitted to vehicle models as per Hayman Reese application guide (www.haymanreese.com.au).

Bumper Cuts



Vehicle and bumper variations can and do occur during vehicle manufacture after initial towbar design. Fitment of towbar to vehicle and accuracy of bumper cut must be assessed prior to any bumper modifications made. Incorrect bumper cuts are not covered under Hayman Reese warranty.

NOTE: Bumper cuts need to be approached with care, refer to notes below.

- Bumper centreline – where the centreline of the bumper needs to be determined, the installer must assess centre point by measurement of bumper width or determining two symmetrical reference points to give centreline.
- Bumper edge – To assist with accurate bumper cut measurement, reference to the start of the bumper edge is now being commonly used.
 - Measure from bottom edge along bumper and around corner to the 70 mm point (Figure 1).
 - Do not measure from visible bumper front of corner, upwards (Figure 2).

CORRECT

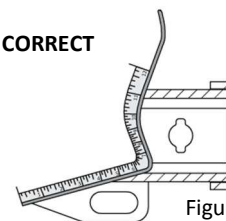

Figure 1

INCORRECT

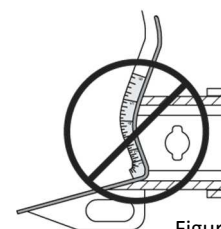

Figure 2

Drilling

- For any required drilling during installation, ensure that the area is clear of fuel, electrical & other components that may be damaged.
- All holes drilled into the body panels shall have all burrs & swarf removed then coated with a suitable rust preventative paint.

Bolts/Fasteners

- Ensure that all hardware is fastened to correct torque as specified in this fitting instruction.
- All fasteners supplied with this product are used to achieve a specified clamp loading. If replacement is required ensure that fasteners of the same grade and class are used.



NOTE: Achieving correct torque is critical to proper installation and responsibility of the installer. Towbar failures attributed to tension issues from over tightening or under tightening are not covered by Hayman Reese warranty.

Product Labels

- a. Towbar load rating sticker provided with this product shall be conspicuously located on inside rear end of the driver's door.
- b. Powertrain Control Module (PCM)/Body Control Module (BCM) upgrade warning label will be provided in towbar kit for vehicles as required. Affix warning label in door and owner's handbook.

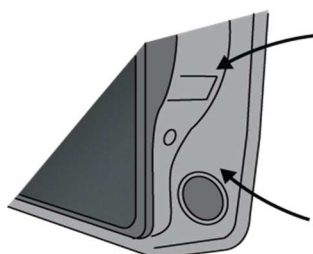

Place **Load Rating sticker** inside driver's door here

Place **Vehicle PCM/ BCM upgrade warning label** in door AND on front cover of owner's service handbook

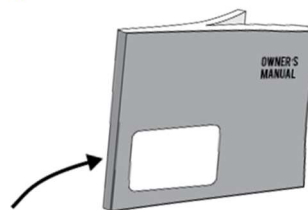

WARNING:

Do not, drill, cut, weld or otherwise modify the towbar.

FOR TOWING PURPOSES ONLY - This towbar is designed and tested by Hayman Reese to adhere to ADR 62/02 which provides only for the expected load demands of towing.



TOWBAR INSTALLATION INSTRUCTIONS

PART NUMBER 03282RW

LDV D90

i TOWBAR ASSEMBLY DIAGRAM

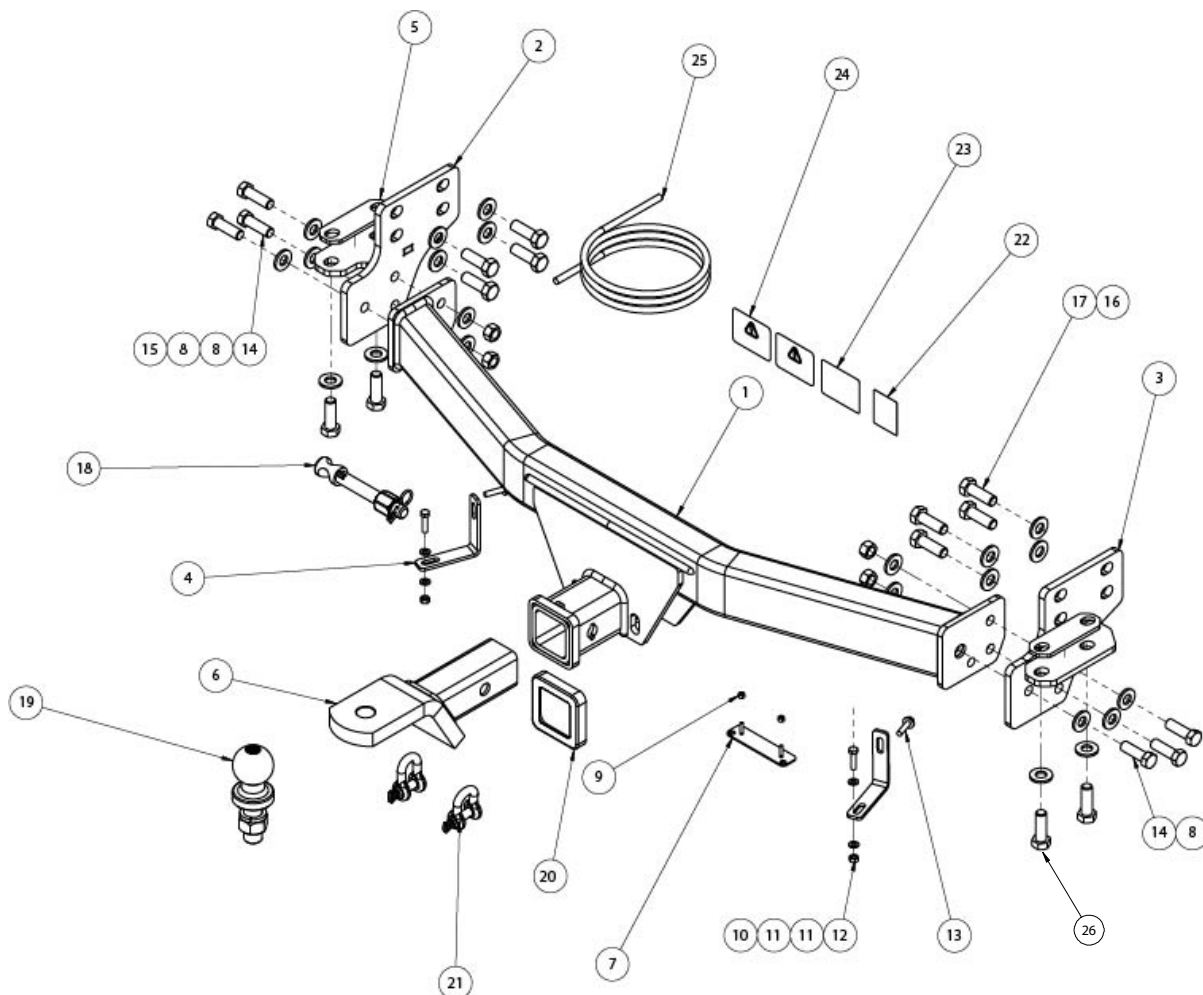

ITEM	DESCRIPTION	QTY
1	LDV D90 WELDED ASSEMBLY	1
2	LHS SIDE ARM ASSEMBLY	1
3	RHS SIDE ARM ASSEMBLY	1
4	BUMPER TAB	2
5	SHIM PLATE	2
6	TRAILER BALL MOUNT	1
7	PLUG BRACKET	1
8	WASHER PLAIN 1/2x1-1/8x16	10
9	NUT NYLON LOCK HEX M4x0.7P	2
10	SET SCREW HEX HD M6x25x1P	2
11	WASHER PLAIN M6x12.5x1.2P	4
12	NUT HEX M6x1.0P	2
13	TEK SCREW 14-20 HEX HD 22mm	2

ITEM	DESCRIPTION	QTY
14	SET SCREW HEX HD M12x40x1.75P	6
15	NUT HEX M12x1.75P	4
16	WASHER PLAIN M14x28x3	12
17	SET SCREW HEX HD M14x35x2P	12
18	SMART PIN	1
19	TOWBALL 50mm	1
20	HITCH BOX COLLAR COVER	1
21	"D" SHACKLE 10mm	2
22	H.R STICKER	1
23	ACRYLIC COMPLIANCE LABEL	1
24	CAN WARNING LABEL	2
25	WIRING LOOM	1
26	SET SCREW HEX HD M14x45x2P	4



TOWBAR INSTALLATION INSTRUCTIONS

PART NUMBER 03282RW

LDV D90

1. Drop spare wheel and exhausts from hangers; support exhausts with a sling if necessary.

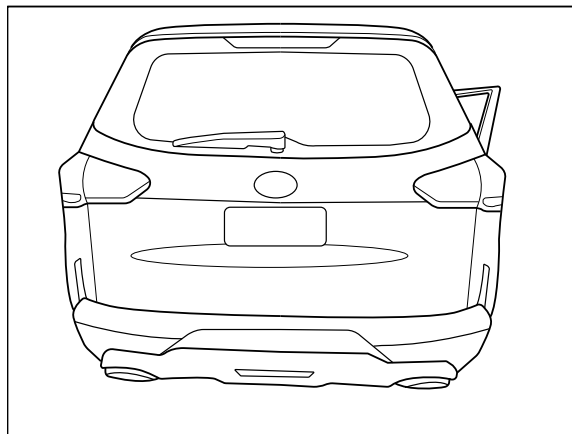

2. Remove 2 x bumper brackets securing bumper in place, secured by 3 x screw per bracket.

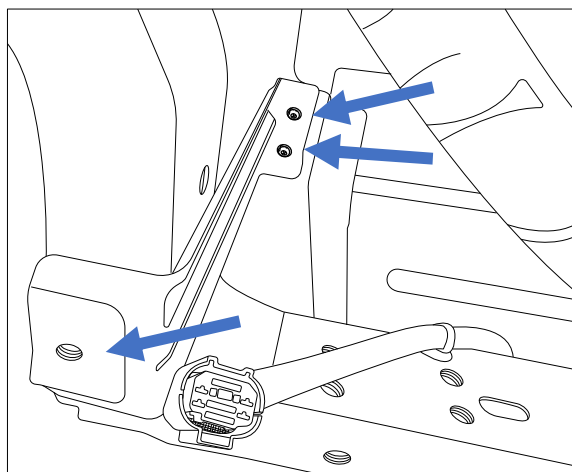

3. Attach sidearm to chassis rail using 6 x M14 bolts (2 x 45mm in vertical direction & 4 x 35mm in horizontal direction) complete with 1 x washer per bolt.

Use spacer plate between sidearm and vertical mount holes where necessary.

Repeat for opposite side.

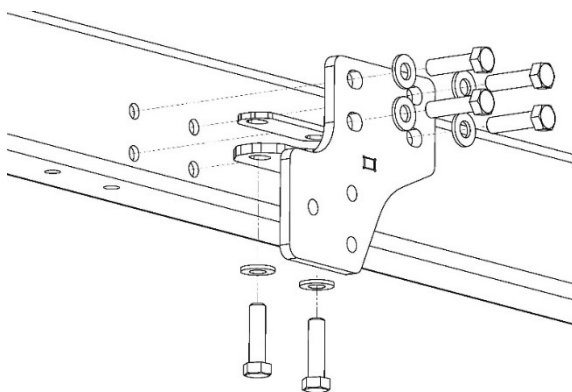



TOWBAR INSTALLATION INSTRUCTIONS

PART NUMBER 03282RW

LDV D90

-
4. Attach 2 x bumper tabs to back of central welded assembly using 1 x tek screw per tab.

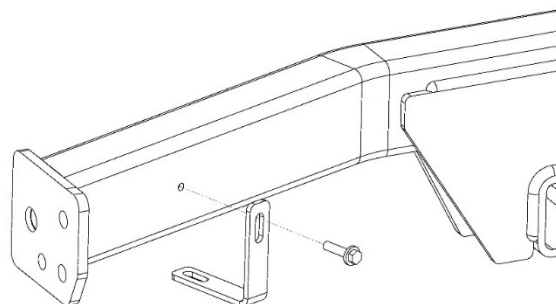

-
5. Using two people, raise centre section up to sidearms. Attach with 3 x M12 bolts per side, complete with nuts and washers.

Torque fasteners as below:

M12 - 77 Nm

M14 - 140 Nm

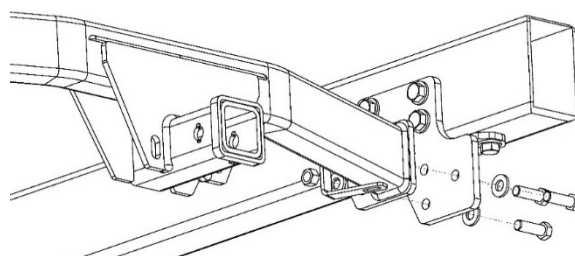

-
6. Secure bumper to bumper tabs using 1 x M6 bolt per tab, complete with 1 x nut and 2 x washers per bolt.

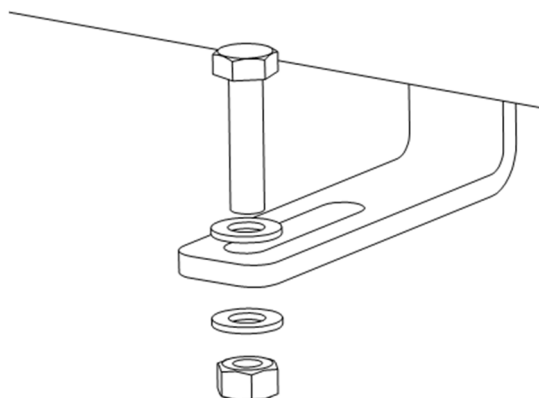



TOWBAR INSTALLATION INSTRUCTIONS

PART NUMBER 03282RW

LDV D90

7. For the plug bracket, find an appropriate position on the bumper. Mark out and drill 2 x \varnothing 5mm holes 69mm apart on bumper skin to support plug bracket.
8. Reattach exhausts to hangers and raise spare wheel.

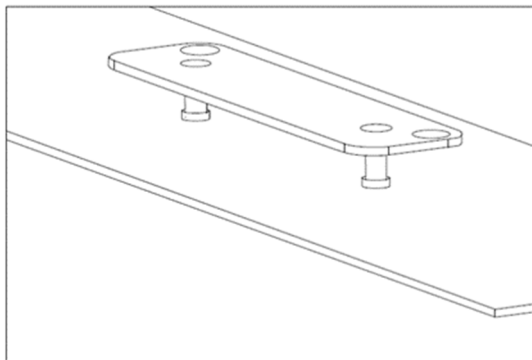

IMPORTANT

Due to possible vehicle variations, always confirm any noted vehicle colour wires with a multi-meter to ensure the correct function is identified before soldering or scotch locking. For vehicle wires denoted with two colours (example; RED/GREEN) the first colour will always be the main wire colour while the second colour is the thinner trace colour on the wire.

9. In the Engine Bay, disconnect the vehicle battery negative terminal (1).

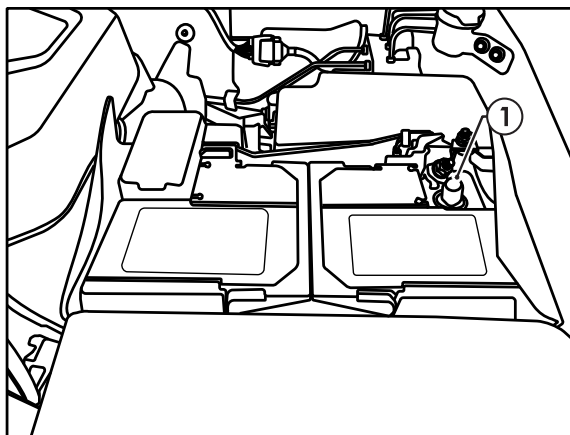



TOWBAR INSTALLATION INSTRUCTIONS

PART NUMBER 03282RW

LDV D90

10. In the luggage compartment, fold the rear row seats forward (1).

11. Remove the rear sunshade (2).

12. Remove the rear boot liner.

13. Remove the tool cover and tray (3).

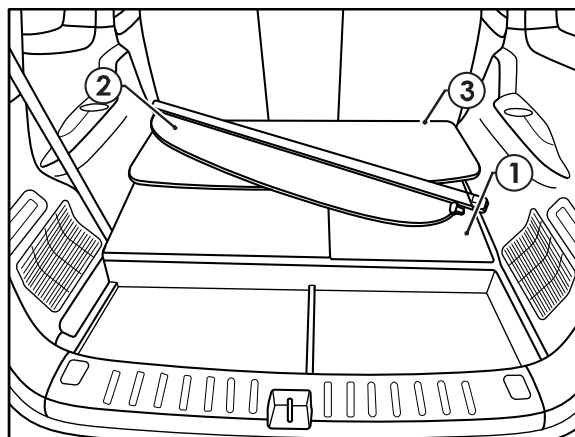

14. On the rear scuff trim, lift up the caps (1) under the hooks which cover the screws.

15. Remove the screws securing the rear scuff trim (2).

16. Remove the rear scuff trim by pulling in an upwards direction.

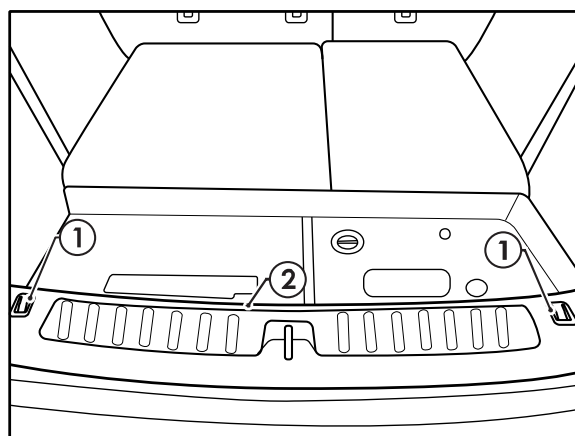

17. Remove the four bolts (1) securing each of the rear row seats (2).

18. Disconnect the seat belt warning connector and then, remove the rear seats from the vehicle.

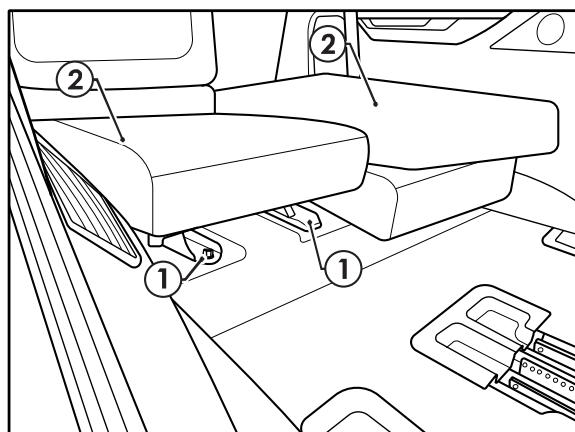



TOWBAR INSTALLATION INSTRUCTIONS

PART NUMBER 03282RW

LDV D90

19. Dislodge the LHS (1) and RHS (2) luggage compartment trims.

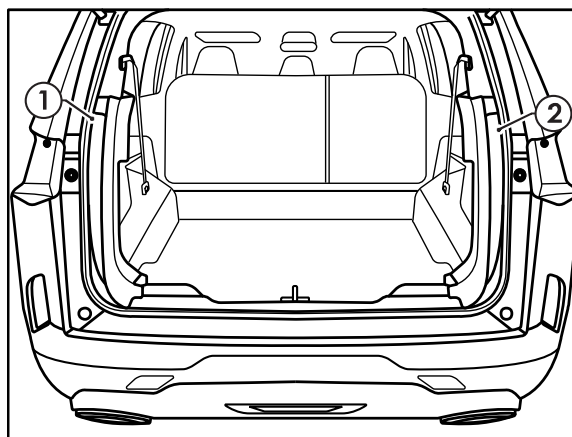

20. Remove the two screws (1) securing the rear tail lights (2).

21. Dislodge the rear tail lights and disconnect the tail light wiring.

22. Remove tail lights from the vehicle.

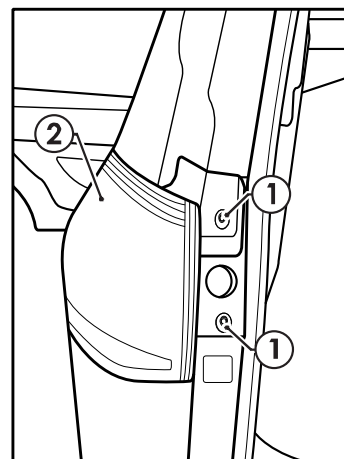

23. At the LHS tail light, unseat the tail light harness grommet (1) and push through the hole and into the vehicle.

Note: For vehicles fitted with a subwoofer this will need to be removed.

24. Inside the vehicle, connect the connector with foam tape on the trailer patch (2) (102182-WL) to the vehicle tail light connector (3) previously pushed through the grommet hole.

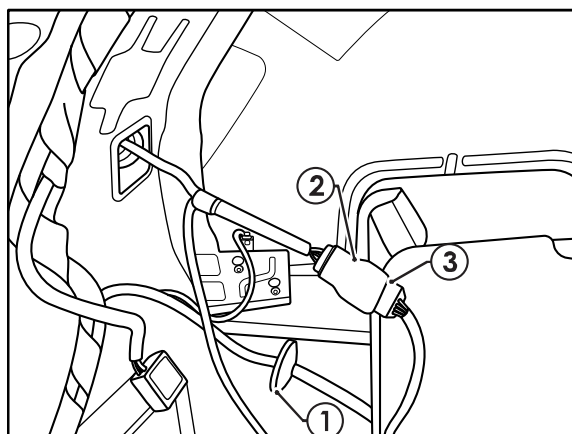

25. Route the trailer patch connector through the grommet hole (1) and to the outside of the vehicle.
26. Seat the grommet (2) on the trailer patch in the vehicle hole.

Note: Ensure grommet is seated correctly and makes a good seal.

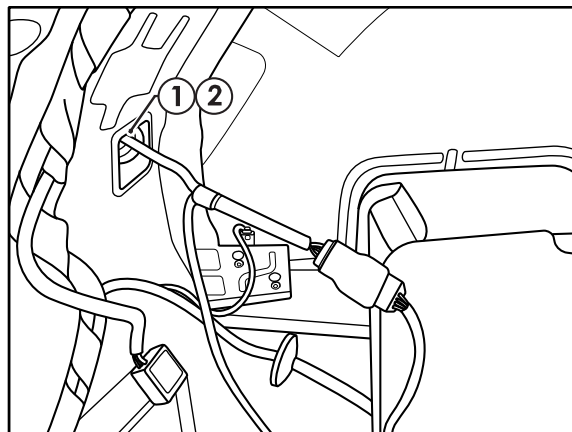

27. Route the ECU white connector down towards the floor.
28. Using an alcohol wipe, clean a suitable location of the LHS inner sheet metal area (1) and the underside of the ECU (04826).
29. Connect the trailer patch 12-way connector (2) to the ECU.

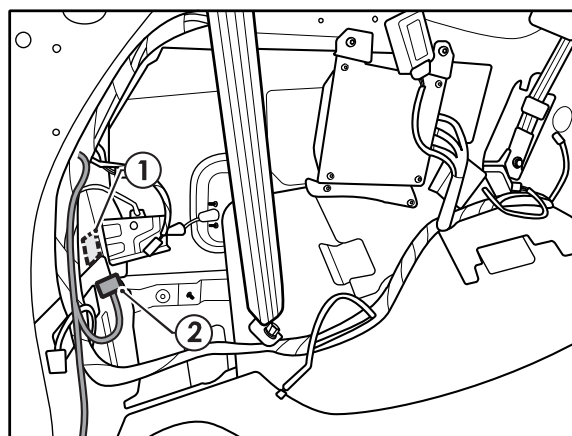

30. Apply double sided tape to the ECU (1) and secure it to the vehicle sheet metal.
31. Secure the ground wire ring terminal (2) to the chassis (3) using a tek screw (not supplied).

Note: Mount the ECU, ensuring the connector is orientated downwards.

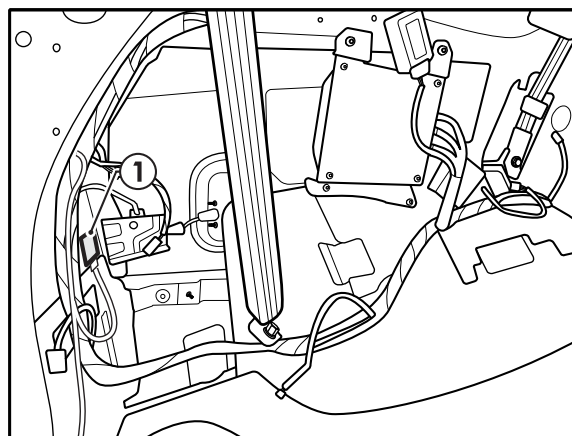



TOWBAR INSTALLATION INSTRUCTIONS

PART NUMBER 03282RW

LDV D90

32. For auto RPA disable, locate the brown wire (1) on the RPA wiring loom running near the down to the floor.
33. Peel back the tape covering to expose the wires inside.
34. Cut the brown (RPA Ground) wire (1) and strip the two exposed ends.
35. Crimp the grey and grey black wires from the trailer patch to the exposed brown wire ends.

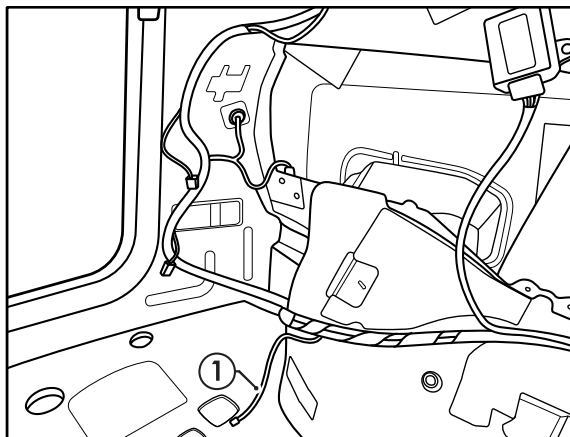

36. Route the trailer patch (1) across to the RHS of the vehicle.
37. At the RHS tail light harness, peel back the tape covering to expose the wires inside.
38. Following the table below, connect the ezy-tap (2) to the vehicle RHS indicator wire (1) then connect the trailer patch wire (3) to the ezy-tap.

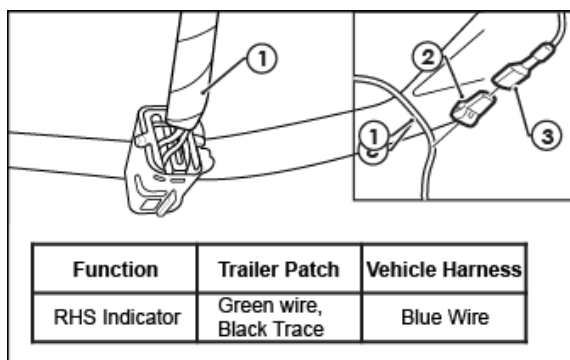

39. Route the harness down towards the RH luggage compartment floor.
40. Locate and remove the 40mm vehicle blanking grommet (1).
41. Route the trailer patch through the grommet hole and seat the grommet in the hole.

Note: Ensure grommet is seated correctly and makes a good seal.

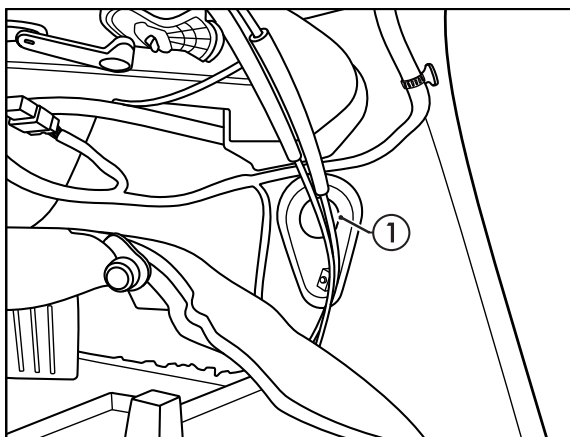

42. Outside the vehicle, pick up the harness under the rear RHS.
43. Connect the power harness one way connector to the trailer patch.
44. Route the power harness (1) up the vehicle towards the vehicle battery.
45. Connect the 8mm ring terminal on the power harness to the vehicle battery positive terminal.

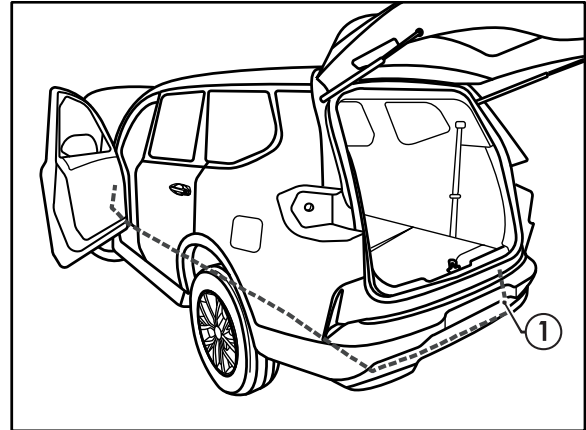

46. With the rear bumper removed, secure tail harness to towbar.
47. Route tail harness towards blue connector on patch loom.

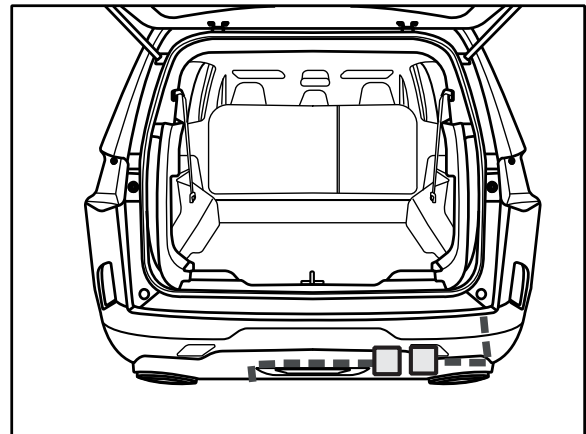

48. Connect the tail harness (tail length 1200mm) 8-way connector (1) to the trailer patch mating 8-way connector (2).
49. Cut-off, crimp the tail harness GREY and GREY/BLACK wires (3) to the trailer patch matching GREY and GREY/BLACK wires (4).
50. Apply silicone grease (not supplied) (5) to waterproof connector.
51. Secure all harness using supplied Cable Ties.

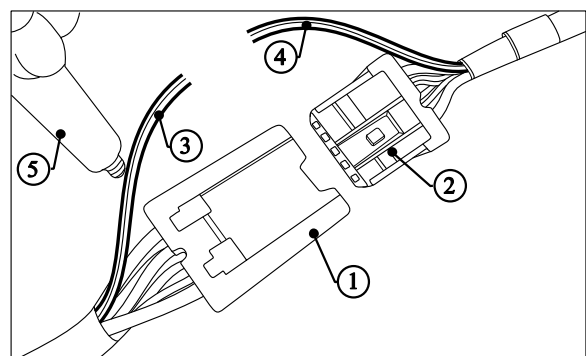



TOWBAR INSTALLATION INSTRUCTIONS

PART NUMBER 03282RW

LDV D90

-
52. Test the trailer patch function using a light board or multi-meter.
 53. Re-fit all removed parts and secure all fasteners, ensuring there are no squeaks or rattles.
 54. Place the fitting instructions in the glove box after fitment.
-



CUSTOMER INFORMATION

PLACE THESE INSTRUCTIONS IN THE
VEHICLE'S GLOVEBOX AFTER INSTALLATION

**THANK YOU FOR PURCHASING HAYMAN REESE.
WITH CORRECT MAINTENANCE AND CARE THIS PRODUCT WILL PROVIDE A
LIFETIME OF TROUBLE-FREE OPERATION.**

i TOWBAR MAINTENANCE AND CARE:

1. Hayman Reese recommend that the towbar LUG or TBM (tow ball Mount) Pull Pin and R-clip are removed and stored when not in use. Removal of LUG or TBM (tow ball mount) is advisable when not in use to assist with any of the following.
 - Ensure rear number plate is not obscured.
 - Allow maximum available departure angle and prevent any potential interference.
 - Prevent possible interference with vehicles reverse sensors or camera detecting a tow ball mount as an obstruction during reversing.
 - Removes towball mount as an obstruction for when moving around the rear of the vehicle.
2. Hayman Reese recommends routine inspection of your towbar to ensure trouble free towing.
 - Bolt security and tension should be regularly inspected and checked for correct tension. Replace any worn or defective parts with suitable grade & class fasteners. Inspection should be requested to coincide with vehicle major services.
3. It is the owner's responsibility to ensure towing and down ball weight capacities of the towing vehicle are not exceeded.
 - Towing and down ball weights allowable may differ according to model variations. Please refer to owner's manual or vehicle dealer to confirm exact rating for your vehicle model variant.
 - It is not uncommon for the vehicle tow rating to differ from the towbar rating. When this occurs, the lesser rating must be adhered to.
 - For vehicles fitted with enhanced vehicle functions that may be altered/changed when towing i.e Trailer sway mitigation, blind spot detection, adaptive cruise control etc. Please consult owner's manual to understand changes enabled when towing and after towing.

i WARRANTY INFORMATION:

Hayman Reese Towbars are covered by a Lifetime Warranty.

Our goods come with guarantees that cannot be excluded under the Australian Consumer Law. You are entitled to a replacement or refund for a major failure and for compensation for any other reasonably foreseeable loss or damage. You are also entitled to have the goods repaired or replaced if the goods fail to be of acceptable quality and the failure does not amount to a major failure.

For further details please visit www.haymanreese.com.au/warranty or contact customer service on 1800 812 017 or info@haymanreese.com.au.



CUSTOMER INFORMATION

PLACE THESE INSTRUCTIONS IN THE VEHICLE'S GLOVEBOX AFTER INSTALLATION

HAYMAN REESE SMART PIN

Your Hayman Reese towbar is equipped with Smart Pin technology to help reduce towbar tongue rattle in most driving conditions. Please ensure below instructions are understood and routine maintenance is carried out to ensure best towing experience.

i Regularly inspect for wear and check the tightness of the Smart Pin Nut. Follow instructions below to re-tighten the nut as necessary when movement and noise in the tow ball mount is noted.

- Before towing, ensure R-Clip is properly installed and Smart pin nut is installed and tensioned. Replacement parts are available from your Hayman Reese Distributor.

TOWBALL MOUNT REMOVAL/INSTALLATION

STEP 1

Insert Trailer Ball Mount (TBM) (a) into towbar hitchbox (b), aligning hole in TBM shank (c) with hole in hitchbox (d) (Fig. 1)

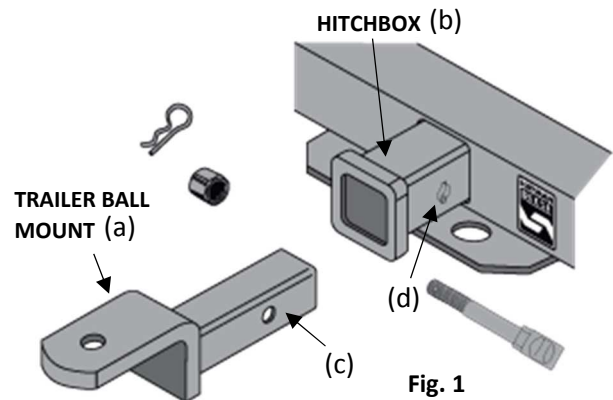

STEP 2

Insert Smart Pin (e) through hole in hitchbox and hole in TBM shank (g); ensure the locators are inserted into the notches in the hitchbox (Fig. 2)

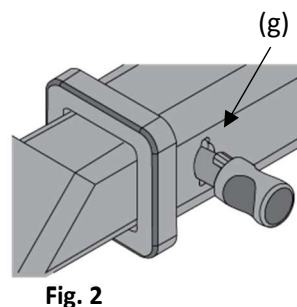

STEP 3

Screw Smart Pin Nut (f) onto Smart Pin (g); tighten Smart Pin Nut until finger tight, ensuring TBM is restrained from up and down movement.

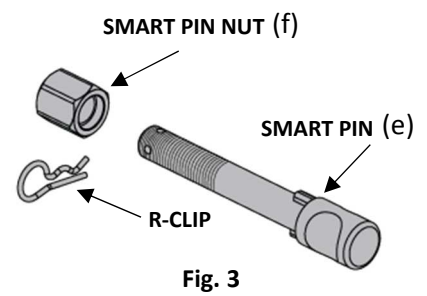

STEP 4

Tighten Smart Pin Nut by turning nut a further 1/8th of a turn in the clockwise direction using a 24mm spanner (Fig. 4).

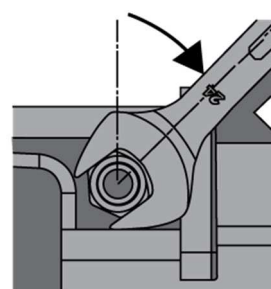

STEP 5

Install Smart Pin R-Clip through the hole that provides best clearance or easiest access. (Fig. 5)

