

HAYMAN REESE
PART No: 03287RW
MITSUBISHI TRITON MQ MY19 XBAR
INSTALLATION INSTRUCTIONS

PLEASE ENSURE THAT INSTRUCTIONS ARE UNDERSTOOD PRIOR TO FITMENT
PLACE THESE INSTRUCTIONS IN THE VEHICLE'S GLOVEBOX AFTER INSTALLATION IS COMPLETED



Installation Time: Approx 60 Mins

Towbar Installation Instructions

MITSUBISHI TRITON MQ MY19 XBAR

Towbar capacity:

Part Number 03287RW	Max Towing Braked	3100kg
	Max Towing Unbraked	700kg
	Max Static Ball Load	310kg

RECOVERY RATING:

CENTRE RECOVERY HOOK

CENTRE RECOVERY POINT LOADING MUST NOT EXCEED 8000kg.
DESIGNED FOR USE WITH A SNATCH STRAP NOT EXCEEDING 8000kg
MBS (MINIMUM BREAKING STRENGTH)

8000kg



SIDE RECOVERY HOOK (SINGLE)

SIDE RECOVERY POINT LOADING MUST NOT EXCEED 4000kg MBS
(MINIMUM BREAKING STRENGTH)

4000kg



Hayman Reese (Cequent)
PO Box 4050, Dandenong South VIC 3164
Phone 1800 812 017 Email info@haymanreese.com.au

x-bar.com.au



HAYMAN REESE
PART No: 03287RW
MITSUBISHI TRITON MQ MY19 XBAR
INSTALLATION INSTRUCTIONS

PLEASE ENSURE THAT INSTRUCTIONS ARE UNDERSTOOD PRIOR TO FITMENT
PLACE THESE INSTRUCTIONS IN THE VEHICLE'S GLOVEBOX AFTER INSTALLATION IS COMPLETED

Warning:

1. Do not, drill, cut, weld or otherwise modify the towbar.
2. If you are using electric welding on a motor vehicle, **always** check that the vehicle is not equipped with electronic engine or instrument management equipment. Failure to do so could **destroy** any on board computers. If in doubt, check with the vehicle's manufacturer.
3. If TBM is used in inverted position tow ball may make contact with rear tailgate when lowered, which could cause damage.

General:

1. Ensure all hardware items have been included refer to assembly diagram.
2. It is recommended that the instructions are read through and completely understood before making any attempt to fit this product.
3. Be wary of any changes to vehicle designs or other accessories that may conflict with the installation of this product.
4. Before drilling ensure that the area is clear of fuel, electrical & other components.
5. All holes drilled into the body panels shall have all burrs & swarf removed then coated with a suitable rust preventative paint.
6. The high tensile fasteners supplied with this product were used to achieve the specified rating. If replacement is required ensure that fasteners of the same rating & quality are used. Contact an authorised **Hayman Reese** dealer if further information is required.
7. Ensure that all hardware is fastened to torque list below check fasteners on regular basis.
8. Towbar load rating sticker provided with this product shall be conspicuously located on inside rear end of the driver's door. **(See diagram below).**
9. Hayman Reese recommends that you check your tow ball to ensure that it complies with the Australian standards **AS 4177.2**.
10. **PLEASE NOTE:** It is advised to remove your LUG or TBM when not actually towing so as to produce a clear view of the vehicles registration plate if obscured, and to also provide maximum available departure angle.

Tow bar Maintenance and Care.

Hayman Reese recommends that bolt torque's, as listed below, are routinely and regularly inspected and checked for correct tension. Replace any worn or defective parts.

We recommended to remove Tow Ball Mounts (TBM's, tongues or lugs) when not being used for any considerable length of time.

So as to avoid injury, when not towing it is suggested that the tongue, Pull Pin and R-clip are removed then stored in a safe, clean and dry place, away from excessive moisture.

Hitch Pull Pins and spring "R" clips are regularly checked for proper installation. Replace any worn or defective parts.

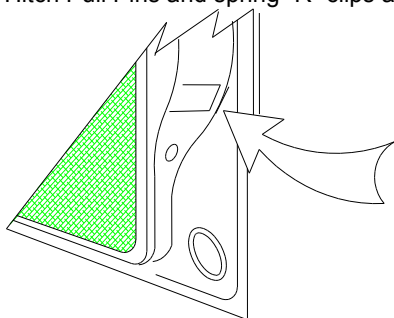

**Place load rating sticker
inside driver's door here**

FOR TOWING PURPOSES ONLY
For towing capacity details please refer to vehicle
owner's manual or to the manufacturer. Overloading can
void your warranties.

Hayman Reese (Cequent)
PO Box 4050, Dandenong South VIC 3164
Phone 1800 812 017 Email info@haymanreese.com.au

x-bar.com.au

X BAR
BY HAYMAN REESE

HAYMAN REESE
PART No: 03287RW
MITSUBISHI TRITON MQ MY19 XBAR
INSTALLATION INSTRUCTIONS

PLEASE ENSURE THAT INSTRUCTIONS ARE UNDERSTOOD PRIOR TO FITMENT
PLACE THESE INSTRUCTIONS IN THE VEHICLE'S GLOVEBOX AFTER INSTALLATION IS COMPLETED

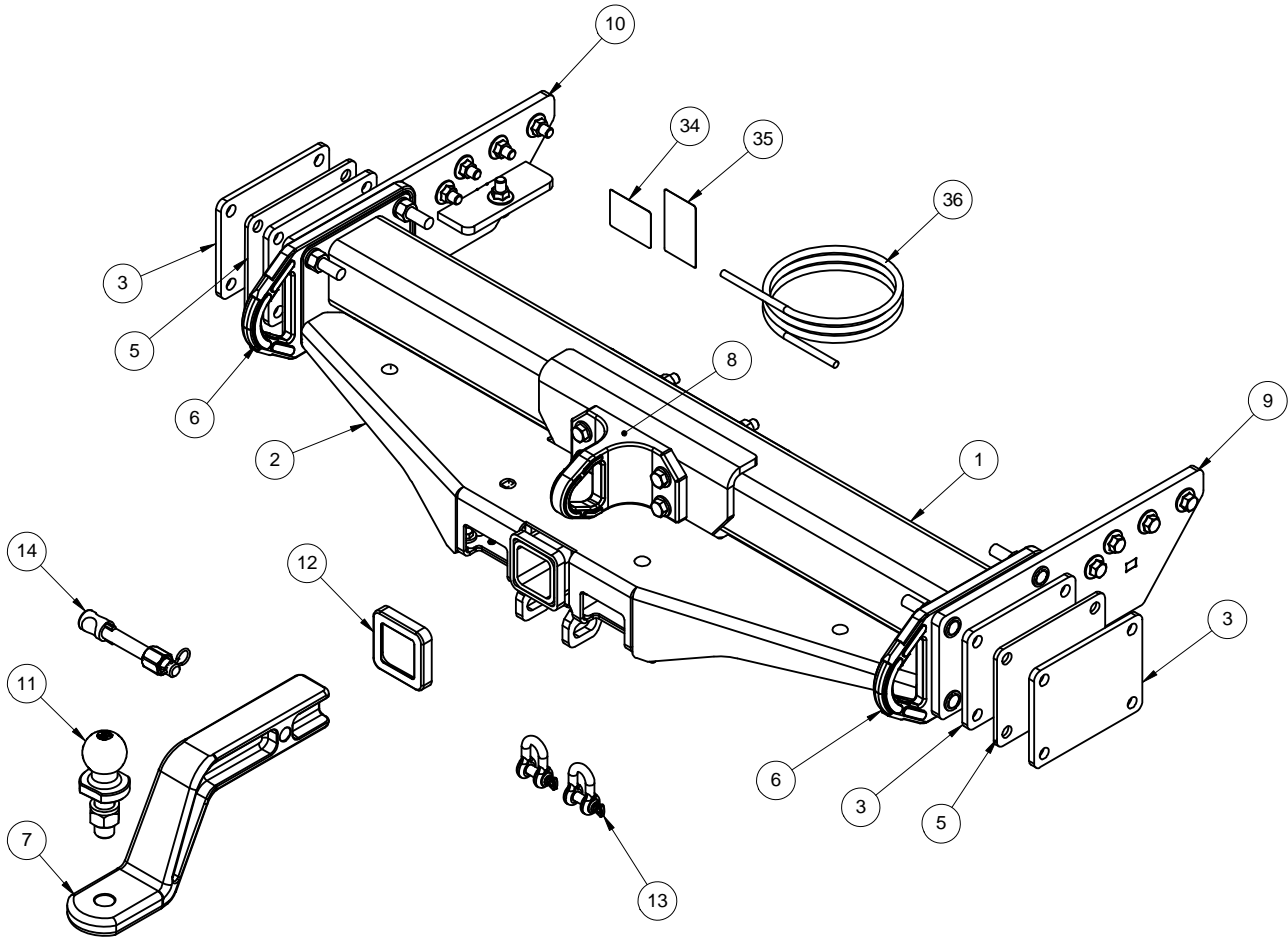

Not all items shown in assembly drawing for clarity

Hayman Reese (Cequent)
PO Box 4050, Dandenong South VIC 3164
Phone 1800 812 017 Email info@haymanreese.com.au

x-bar.com.au



HAYMAN REESE
PART No: 03287RW
MITSUBISHI TRITON MQ MY19 XBAR
INSTALLATION INSTRUCTIONS

PLEASE ENSURE THAT INSTRUCTIONS ARE UNDERSTOOD PRIOR TO FITMENT
 PLACE THESE INSTRUCTIONS IN THE VEHICLE'S GLOVEBOX AFTER INSTALLATION IS COMPLETED

ITEM NO.	DESCRIPTION	QTY.
1	XBAR WELDED ASSEMBLY	1
2	BOLT ON PLATE - MODEL C	1
3	8MM SPACER PLATE	4
4	BASH PLATE	1
5	5MM SPACER PLATE	2
6	FORGED SIDE RECOVERY PLATES	2
7	3.5t FORGED TBM EXTENDED DROP	1
8	FORGED CENTRE RECOVERY MOUNT	1
9	MITSUBISHI TRITON XBAR SIDE ARM RHS	1
10	TRITON D-CAB WO STEP SIDE ARM LHS	1
11	HR TOWBALL	1
12	HITCH BOX COLLAR COVER	1
13	10mm "D" SHACKLE	2
14	ANTI-RATTLE PULL PIN ASSY GOLD	1
15	FLANGED NUT HEX M12x1.25P G10	10
16	FLANGED SET SCREW M12x35x1.25P GR10.9	10
17	M12x1.75 HEX NUT PC8	4
18	WSHR FT M12 x 28 x 3mm BLK XYLAN	24
19	SPACER TUBE 90MM 16X1.6	4
20	BOLT M10-1.25x35mm Gr8.8 BLK XYLAN	2
21	SCREW PAN HD M3 X 20 X 0.7P G4.6	2
22	NUT NYLON LOCK HEX HD M4X0.7P G8	2
23	SCREW PAN HD M4 X 16 X 0.7P G4.6	2
24	NUT NYLON LOCK HEX HD M3X0.7P G8	2
25	SET SCREW M8 - 1.25 x 25mm GR 8.8 Z/P	2
26	WASHER PLAIN M8 X 22 X 3	8
27	M8 - 1.25 NUT	6
28	WSHR FT M10 x 25.4 x 3mm BLK XYLAN	2
29	SCR-HEX-ISO4014-10.9-WS18-M12X150	4
30	SCR-HEX-ISO4014-10.9-WS21-M14X65	8
31	NUT-HEX-ISO4032-10-WS21-M14	8
32	BLT-NUT-AS1390/1112-4.6/5-(A2K)-M8X20	4
33	XBAR DECAL STICKER	1
34	ACRYLIC COMPLIANCE LABEL	1
35	ACRYLIC LOAD RATING LABEL	1
36	WIRING LOOM	1

Hayman Reese (Cequent)
 PO Box 4050, Dandenong South VIC 3164
 Phone 1800 812 017 Email info@haymanreese.com.au

x-bar.com.au



HAYMAN REESE
PART No: 03287RW
MITSUBISHI TRITON MQ MY19 XBAR
INSTALLATION INSTRUCTIONS

PLEASE ENSURE THAT INSTRUCTIONS ARE UNDERSTOOD PRIOR TO FITMENT
PLACE THESE INSTRUCTIONS IN THE VEHICLE'S GLOVEBOX AFTER INSTALLATION IS COMPLETED

1. Loosely secure RH side arm to chassis rail via 4 x M12 bolts on the outboard side of chassis rail and 1 x M12 bolts on underside of chassis, complete with 1 x nut per bolt.

Repeat for opposite side.

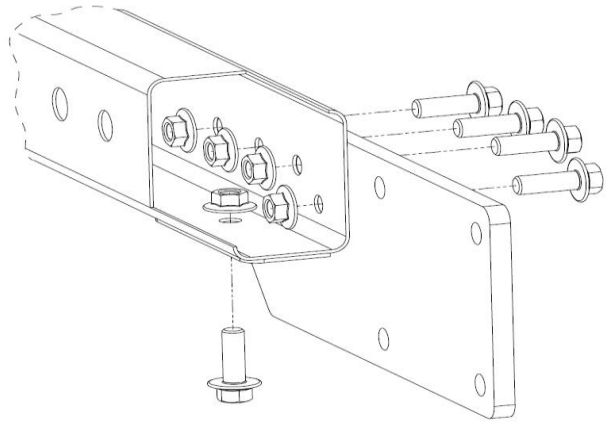

2. Using two people, lift towbar up to side arms ensuring to sandwich red recovery side plate between side arms and cross tube, with 2 x 8mm and 1 x 5mm spacer plates in recess of red plate.

Note: Red recovery side plates must have recess facing inwards.

Loosely secure towbar to side arms with 4 x M14 bolts complete with 2 x washers and 1 x nut per bolt.

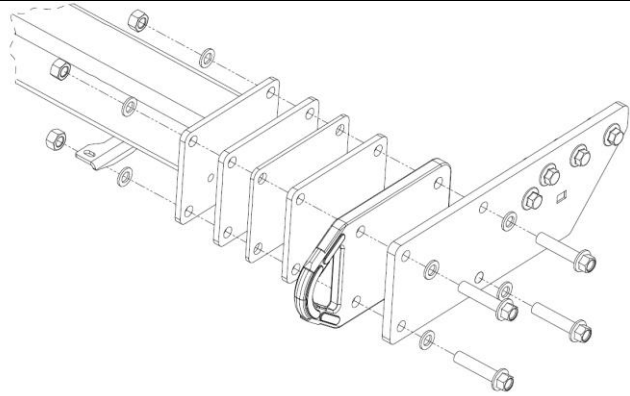

3. Refer to sequence A, B, C, and D over page for final assembly instructions.

4. Tighten all bolts to the torques listed below:

M8: 22 N.m ; M10: 48 N.m; M12: 140 N.m; M14: 175 N.m

IMPORTANT: Ensure all bolts are secured to correct torques using a calibrated torque wrench. Tighten side arms to chassis rail first in an even pattern/sequence. Repeat for centre section to side arms and finally torque all other fasteners.

Hayman Reese (Cequent)
PO Box 4050, Dandenong South VIC 3164
Phone 1800 812 017 Email info@haymanreese.com.au

x-bar.com.au



HAYMAN REESE

PART No: 03287RW

MITSUBISHI TRITON MQ MY19 XBAR

INSTALLATION INSTRUCTIONS

PLEASE ENSURE THAT INSTRUCTIONS ARE UNDERSTOOD PRIOR TO FITMENT
PLACE THESE INSTRUCTIONS IN THE VEHICLE'S GLOVEBOX AFTER INSTALLATION IS COMPLETED

A. FIT PLUGS TO PLUG BRACKETS

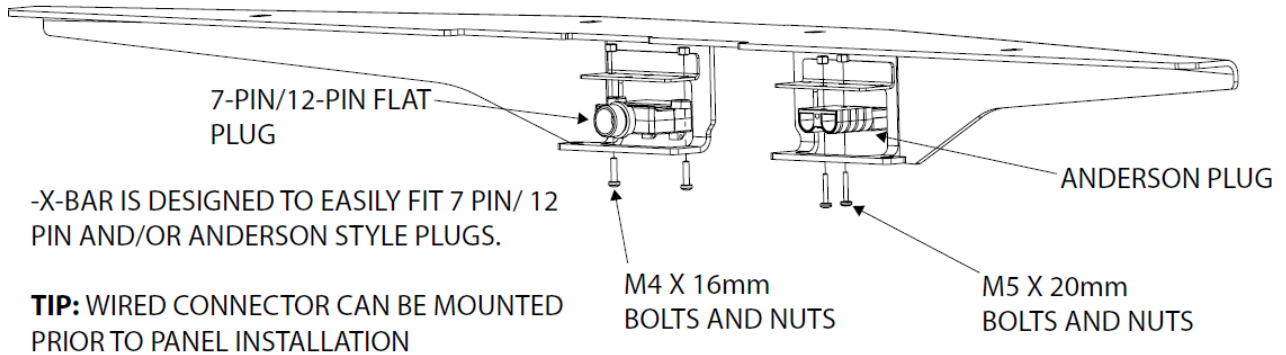

B. BOLT COVER PLATE TO TOWBAR

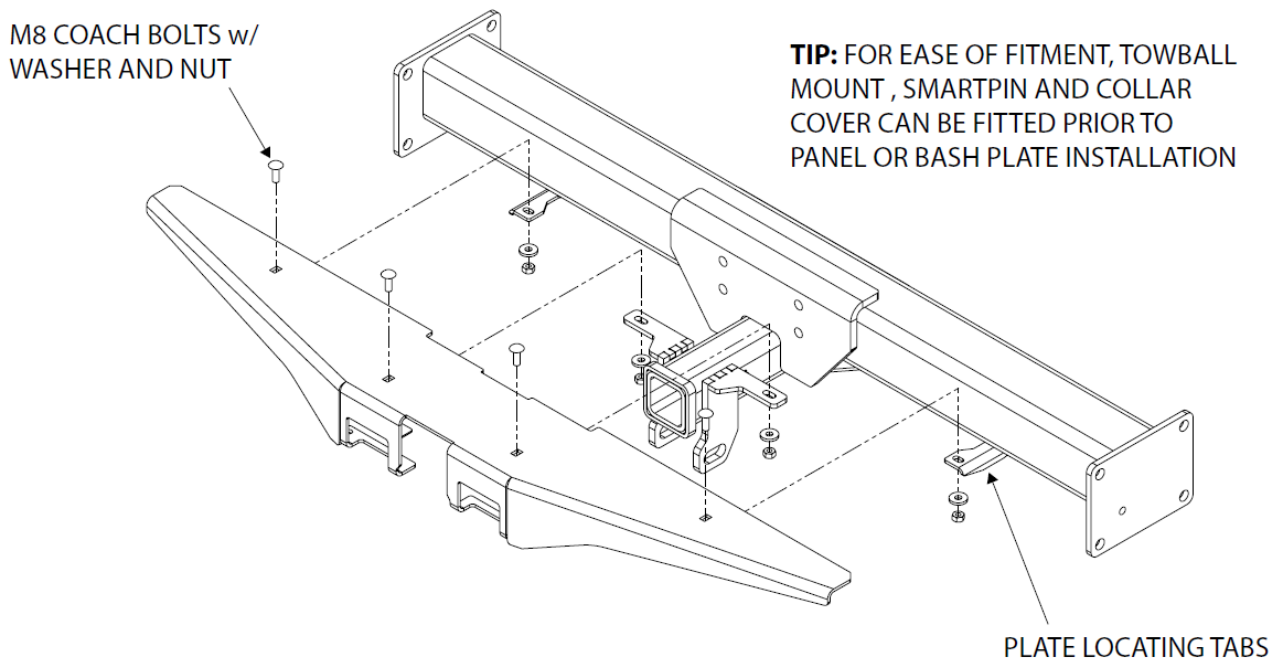

Hayman Reese (Cequent)
PO Box 4050, Dandenong South VIC 3164
Phone 1800 812 017 Email info@haymanreese.com.au

x-bar.com.au

X BAR
BY HAYMAN REESE

HAYMAN REESE
PART No: 03287RW
MITSUBISHI TRITON MQ MY19 XBAR
INSTALLATION INSTRUCTIONS

PLEASE ENSURE THAT INSTRUCTIONS ARE UNDERSTOOD PRIOR TO FITMENT
PLACE THESE INSTRUCTIONS IN THE VEHICLE'S GLOVEBOX AFTER INSTALLATION IS COMPLETED
C. BOLT CENTRE RECOVERY HOOK TO TOWBAR

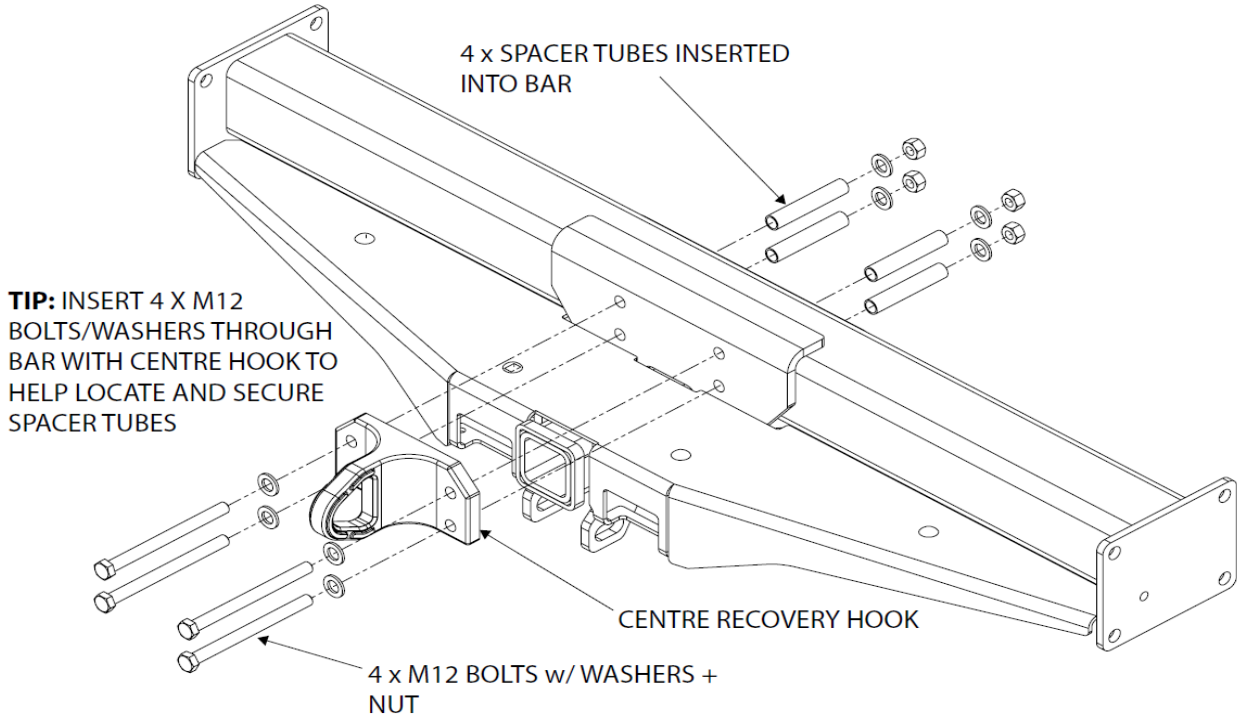

D. BOLT BASH PLATE TO TOWBAR

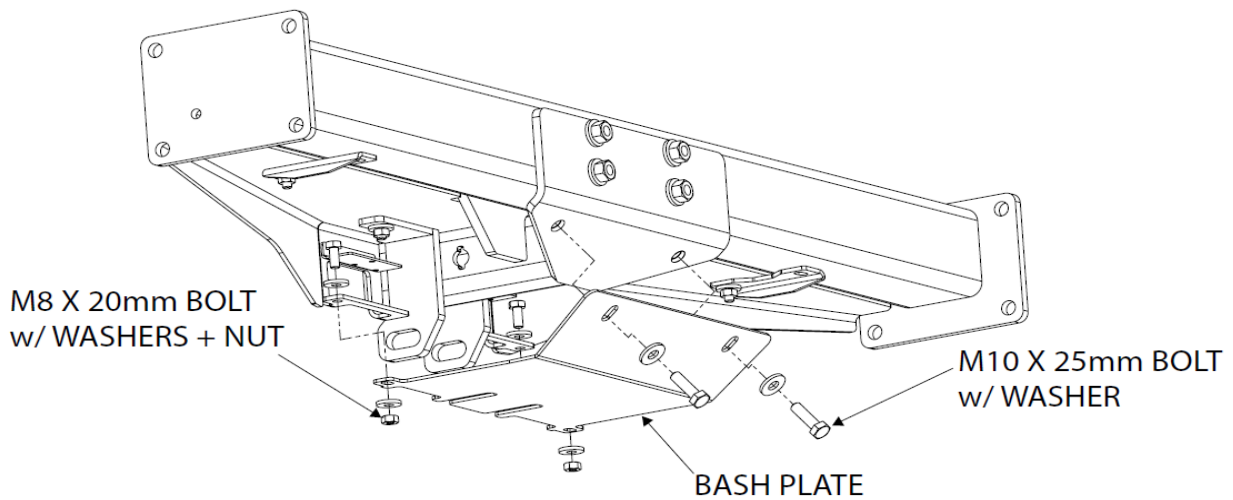

Hayman Reese (Cequent)
PO Box 4050, Dandenong South VIC 3164
Phone 1800 812 017 Email info@haymanreese.com.au

x-bar.com.au

XBAR
BY HAYMAN REESE

HAYMAN REESE
PART No: 102148-WL
MITSUBISHI TRITON

INSTALLATION INSTRUCTIONS

PLEASE ENSURE THAT INSTRUCTIONS ARE UNDERSTOOD PRIOR TO FITMENT

Wiring Loom Installation Instructions

MITSUBISHI TRITON

Part No: 102148-WL

Tail Harness Length Required: 1200mm

ECU - N/A

RPA Disable - N/A

**Electric Brake Input Location: Blue Wire Near Connector
Breakout**

Wiring Loom Installation Time: Approx. 15 minutes

Issue Date 01-02-19

Page 1

Part No: 102148-WL

Hayman Reese (Cequent)
PO Box 4050, Dandenong South VIC 3164
Phone 1800 812 017 Email info@haymanreese.com.au



www.haymanreese.com.au

HAYMAN REESE
PART No: 102148-WL
MITSUBISHI TRITON

INSTALLATION INSTRUCTIONS

PLEASE ENSURE THAT INSTRUCTIONS ARE UNDERSTOOD PRIOR TO FITMENT

1. In the engine bay, disconnect the negative vehicle battery cable (1).

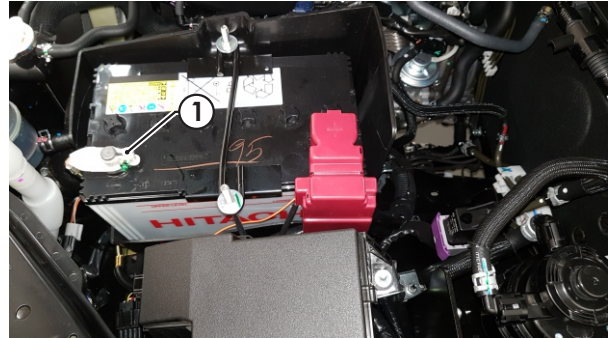

2. Under the vehicle LHS near the spare wheel, locate the vehicle black 10-way connector pair (1).

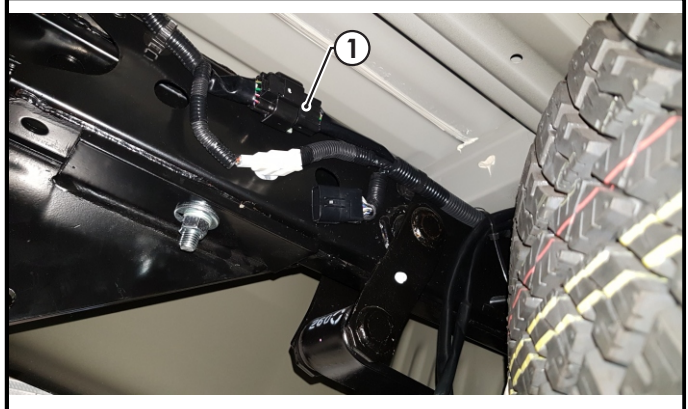

3. Disconnect the vehicle connectors and patch in the supplied Patch Harness in between the vehicle connectors.
4. Tie up excess length and waterproof relays to the existing vehicle harness.



Issue Date 01-02-19

Page 2

Part No: 102148-WL

Hayman Reese (Cequent)
PO Box 4050, Dandenong South VIC 3164
Phone 1800 812 017 Email info@haymanreese.com.au

HAYMAN REESE
PART No: 102148-WL
MITSUBISHI TRITON

INSTALLATION INSTRUCTIONS

PLEASE ENSURE THAT INSTRUCTIONS ARE UNDERSTOOD PRIOR TO FITMENT

5. Route the power and ground wire under the vehicle towards the front of the vehicle following the left hand chassis rail.
6. Route the power and ground wire up in the engine bay, towards the vehicle battery (1).

Note: Keep harness routing clear of all sharp edges, moving parts and places of extreme heat.



7. Connect the orange power wire ring terminal to the battery (1).
8. Connect the white ground wire to the vehicle earthing point (2).

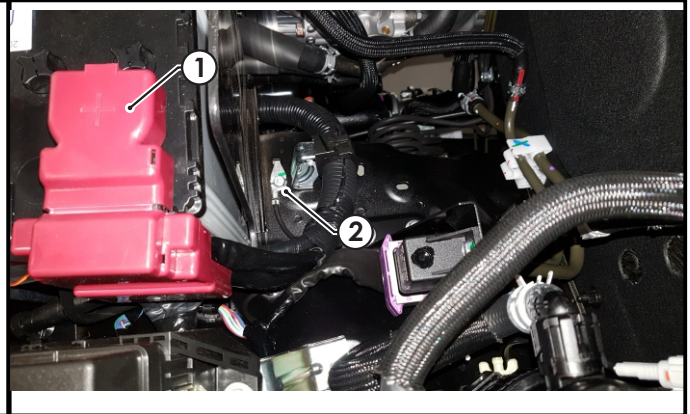

9. Secure tail harness to towbar
10. Connect the tail harness (tail length 1200mm) 8-way connector (1) to the trailer patch mating 8-way connector (2).
11. Apply silicone grease (3) (not supplied) to waterproof connector.
12. Secure all harnesses using supplied Cable Ties.
13. Test the trailer patch function using a light board or multi-meter.
15. Place the fitting instructions in the glove box after fitment.

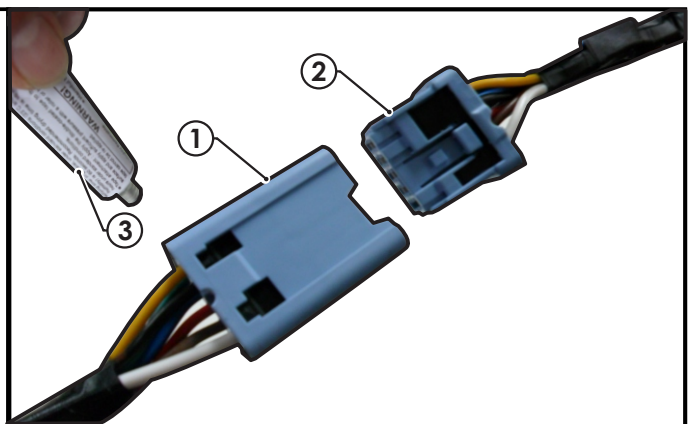

Issue Date 01-02-19

Page 3

Part No: 102148-WL

Hayman Reese (Cequent)
PO Box 4050, Dandenong South VIC 3164
Phone 1800 812 017 Email info@haymanreese.com.au



FITTING INSTRUCTIONS

Smart Pin (55070BL)

• These fitting instructions are supplied to ensure understanding of how the SMART PIN should be fitted and used correctly.

• Once installed, we recommend **ALL** instructions are kept and placed in the vehicle glove box.

NOTE: Routine maintenance and inspection of the towbar & SMART PIN is required. Regularly inspect for wear and check the tightness of the SMART PIN NUT. Follow instructions below to retighten the nut when necessary.

***Do not tow with your vehicle if the R CLIP or the SMART PIN NUT is loose or missing. Replacement parts are available from your Hayman Reese Distributor.**

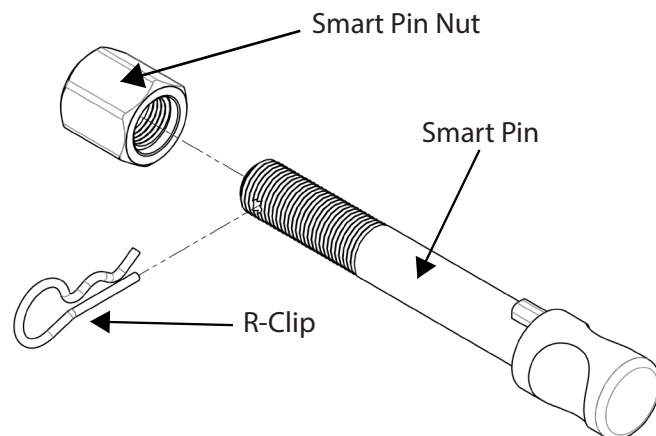
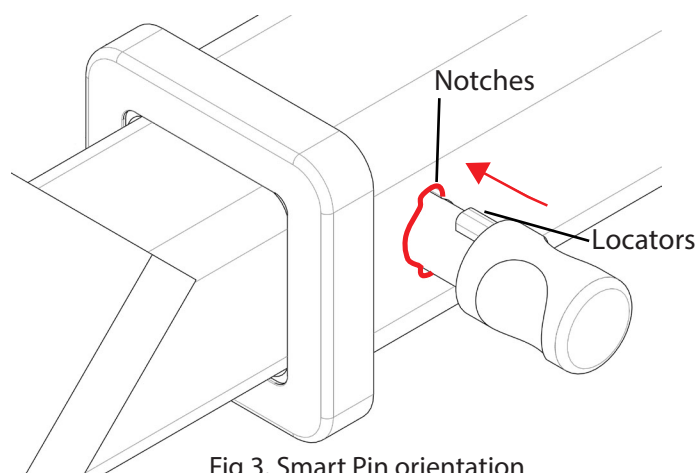
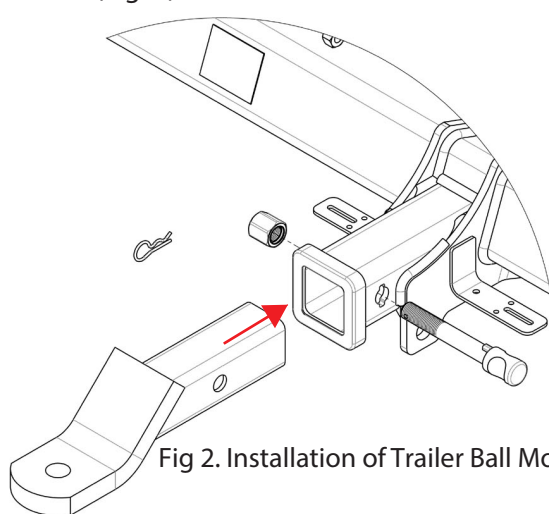

Fig 1. Smart Pin assembly

STEP 1 Insert Trailer Ball Mount (TBM) into towbar HITCHBOX, aligning hole in TBM SHANK with hole in HITCHBOX (Fig. 2).



STEP 2 Insert SMART PIN through hole in HITCHBOX and hole in TBM SHANK; ensure the LOCATORS are inserted into the NOTCHES in the HITCHBOX (Fig. 3).

STEP 3 Screw SMART PIN NUT onto SMART PIN; tighten SMART PIN NUT until finger tight, ensuring TBM is restrained from movement.

STEP 4 Tighten SMART PIN NUT by turning nut a further 1/8th of a turn in the clockwise direction using a 24mm spanner (Fig 4).

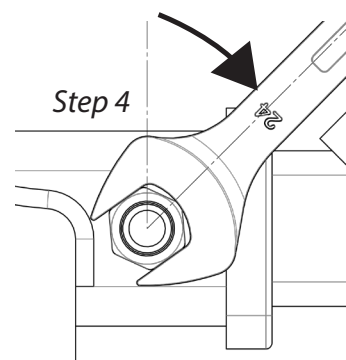

STEP 5 Install SMART PIN R CLIP through the hole on the SMART PIN (Fig. 1).

