



TOWBAR INSTALLATION INSTRUCTIONS

PART NUMBER 03327RW

FIAT DUCATO SERIES 6 CL4



PRODUCT DETAILS:

Part Number:	03327RW	Maximum Towing Braked:	3000	kg
ECU Number:	04826	Maximum Towing Unbraked:	750	kg
Tail Harness Length Required:	1800mm	Maximum Static Ball Load:	120	kg
TBM/Lug Part Number:	21325/21372			
Wiring Part Number:	102286-WL			

FITTING DETAILS:

Towbar Installation Time:	60 Mins.	Hayman Reese SmartCODE Solution Required:	No
Wiring Installation Time:	30 Mins.	RPA Disable/Other : Yes	
Total Installation Time:	90 Mins.	Note:	
Bumper Cut Required:	No		<ul style="list-style-type: none">• Use tail 04937• Electric brake blue wire located next to blue connector.



TOWBAR INSTALLATION INSTRUCTIONS

PART NUMBER 03327RW

FIAT DUCATO SERIES 6 CL4

ENSURE THAT INSTRUCTIONS ARE UNDERSTOOD PRIOR TO FITMENT.

i BEFORE YOU START:

Hayman Reese recommends that instructions are read completely prior to fitment. Check all hardware items have been included refer to assembly diagram. Please ensure this towbar is only fitted to vehicle models as per Hayman Reese application guide (www.haymanreese.com.au).

Bumper Cuts



Vehicle and bumper variations can and do occur during vehicle manufacture after initial towbar design. Fitment of towbar to vehicle and accuracy of bumper cut must be assessed prior to any bumper modifications made. Incorrect bumper cuts are not covered under Hayman Reese warranty.

NOTE: Bumper cuts need to be approached with care, refer to notes below.

- Bumper centreline – where the centreline of the bumper needs to be determined, the installer must assess centre point by measurement of bumper width or determining two symmetrical reference points to give centreline.
- Bumper edge – To assist with accurate bumper cut measurement, reference to the start of the bumper edge is now being commonly used.
 - Measure from bottom edge along bumper and around corner to the 70 mm point (Figure 1).
 - Do not measure from visible bumper front of corner, upwards (Figure 2).

CORRECT

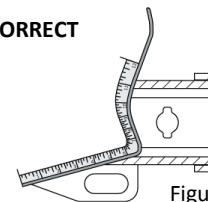

Figure 1

INCORRECT

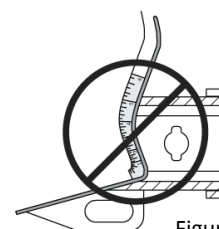

Figure 2

Drilling

- For any required drilling during installation, ensure that the area is clear of fuel, electrical & other components that may be damaged.
- All holes drilled into the body panels shall have all burrs & swarf removed then coated with a suitable rust preventative paint.

Bolts/Fasteners

- Ensure that all hardware is fastened to correct torque as specified in this fitting instruction.
- All fasteners supplied with this product are used to achieve a specified clamp loading. If replacement is required ensure that fasteners of the same grade and class are used.



NOTE: Achieving correct torque is critical to proper installation and responsibility of the installer. Towbar failures attributed to tension issues from over tightening or under tightening are not covered by Hayman Reese warranty.

Product Labels

- a. Towbar load rating sticker provided with this product shall be conspicuously located on inside rear end of the driver's door.
- b. Powertrain Control Module (PCM)/Body Control Module (BCM) upgrade warning label will be provided in towbar kit for vehicles as required. Affix warning label in door and owner's handbook.

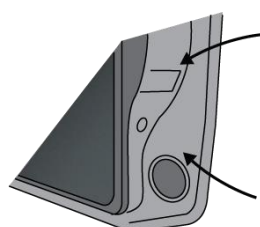

Place **Load Rating sticker** inside driver's door here

Place **Vehicle PCM/ BCM upgrade warning label** in door AND on front cover of owner's service handbook

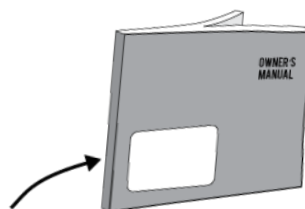

WARNING:

Do not, drill, cut, weld or otherwise modify the towbar.

FOR TOWING PURPOSES ONLY - This towbar is designed and tested by Hayman Reese to adhere to ADR 62/02 which provides only for the expected load demands of towing.



TOWBAR INSTALLATION INSTRUCTIONS

PART NUMBER 03327RW

FIAT DUCATO SERIES 6 CL4

i TOWBAR ASSEMBLY DIAGRAM

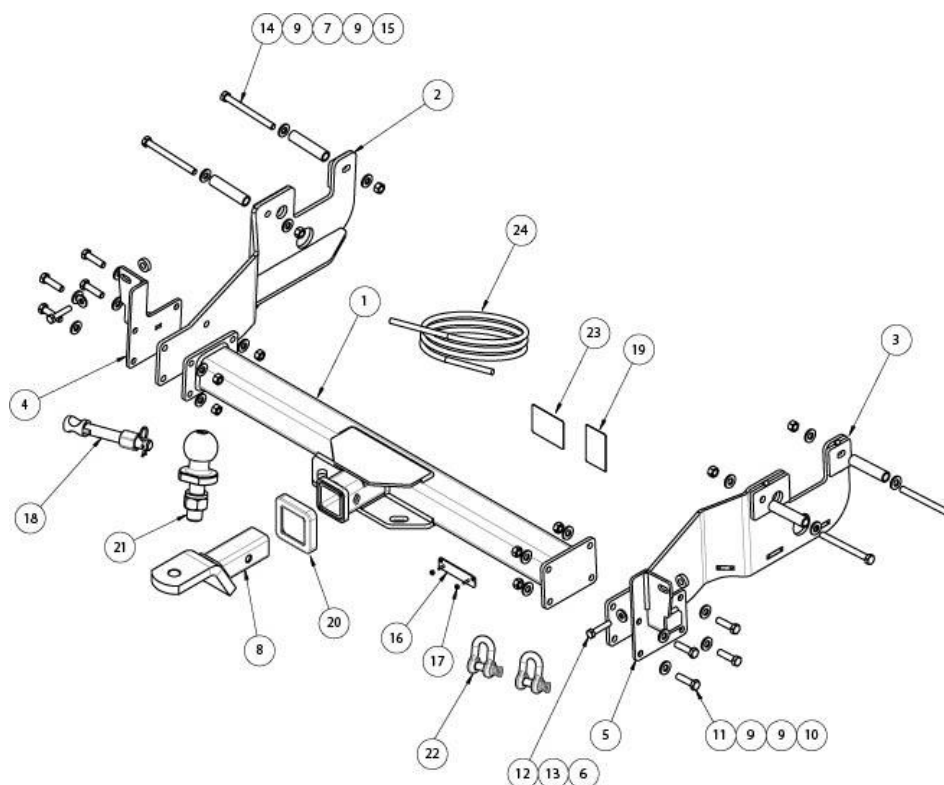

ITEM	DESCRIPTION	QTY
1	FIAT DUCATO SERIES 6 WELDED ASSY	1
2	SIDE ARM ASSY LH	1
3	SIDE ARM ASSY RH	1
4	REAR MOUNT ASSY LHS	1
5	REAR MOUNT ASSY RHS	1
6	SPACER 8MM	2
7	SPACER TUBE HOLLOW	4
8	TRAILER BALL MOUNT	1
9	WASHER PLAIN M12x27x3.0	24
10	NUT HEX HD M12x1.25P	8
11	SET SCREW HEX HD M12x45x1.25P	8
12	BOLT HEX HD M10x50x1.25P	2

ITEM	DESCRIPTION	QTY
13	WASHER PLAIN M10x25x3	2
14	BOLT HEX HD M12x130x1.75P	4
15	NUT HEX HD M12x1.75P	4
16	PLUG BRACKET	1
17	NUT NYLOC HEX HD M4x0.7P	2
18	SMART PIN GOLD	1
19	H.R STICKER	1
20	HITCH BOX COLLAR COVER	1
21	TOWBALL 50mm	1
22	"D" SHACKLE 10mm	2
23	COMPLIANCE LABEL	1
24	WIRING LOOM	1

1. Lower spare wheel as per vehicle user manual.
2. Open rear doors.
3. Remove 4 x torx screws along the top edge of the bumper.

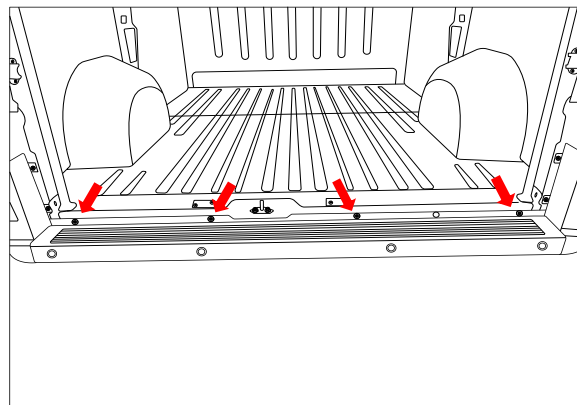

4. Remove 4 x torx screws from under the bottom of the bumper. (RH side shown)

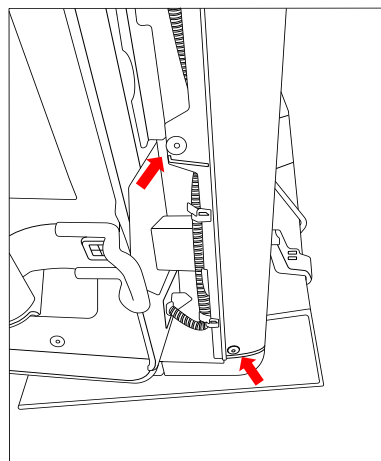

5. Remove bumper, ensuring to disconnect the wiring harness located on the RH side, inside the body cavity, behind the rubber seal.

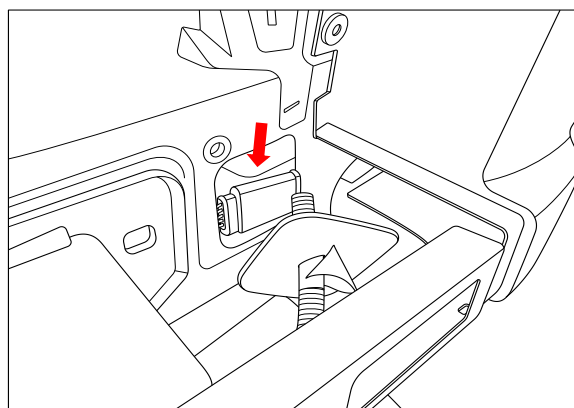

6. The impact beam remains on the vehicle, however, remove and discard the inner mounting bolt.

The nut and bolt securing the bottom of the impact beam may have to be loosened to assist with the bolt fitment at a later stage.

Repeat for other side.

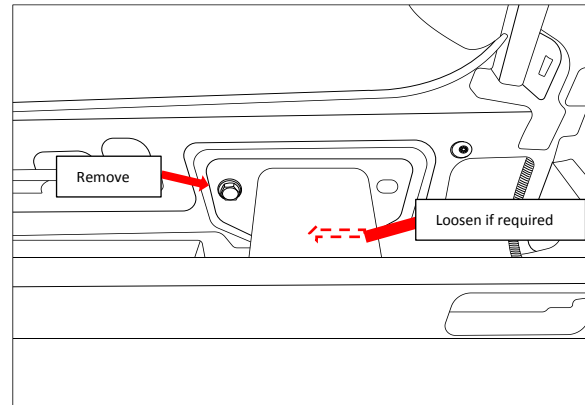

7. Locate the 2 x mounting holes on the inside of the chassis rail and drill them out to 22mm to accommodate the crush tube. Ensure to only drill the inside face of the chassis rail.

Deburr sharp edges and protect the exposed material with an anti-corrosion coating.

Repeat for the other side.

(RH side shown with the spare wheel mechanism)

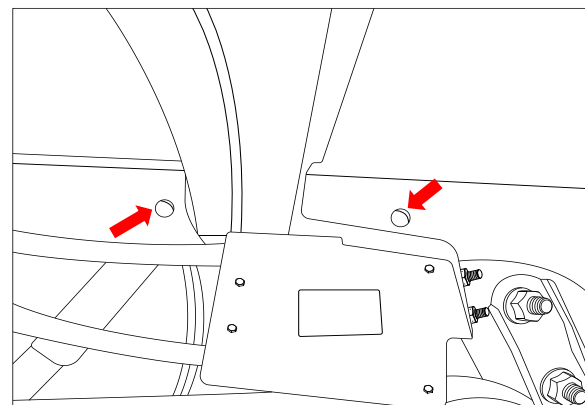

8. Insert the crush tubes into the mounting holes and loosely secure the RH side arm assembly to the chassis rail with 2 x M12 x 130 bolts complete with 2 x washers and 1 x nut per bolt.

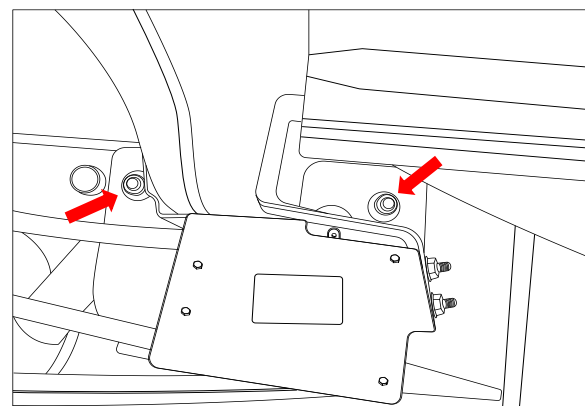



TOWBAR INSTALLATION INSTRUCTIONS

PART NUMBER 03327RW

FIAT DUCATO SERIES 6 CL4

9. Loosely secure the RHS rear mount assy, along with the impact beam to the vehicle with 1 X M10 bolt complete with 1 x 8mm Spacer and 1 x washer.

Ensure to place the 8mm spacer between the impact beam and the side arm assy.

Repeat for other side.

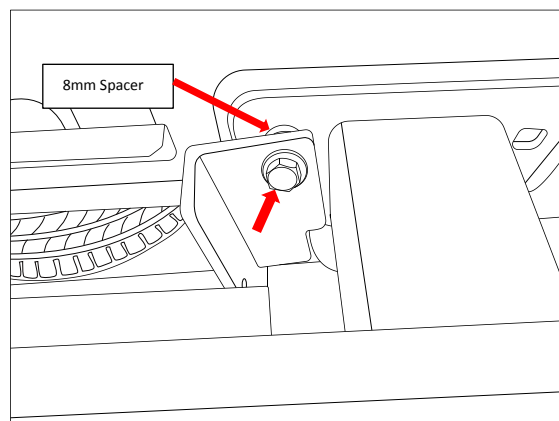

10. Support the crosstube and loosely secure to the side arm and the rear mount assemblies with 8 x M12 bolts complete with 2 x washers and 1 x nut per bolt (4 per side).

11. Position the towbar assembly and tighten all fasteners to the specified torque.

M10 Grade 8.8 : 44Nm
M12 Grade 8.8 : 89Nm
M12 Grade 10.9 : 109Nm

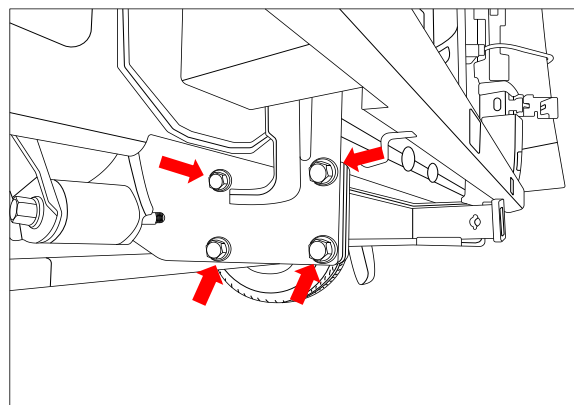



TOWBAR INSTALLATION INSTRUCTIONS

PART NUMBER 03327RW

FIAT DUCATO SERIES 6 CL4

IMPORTANT

Due to possible vehicle variations, always confirm any noted vehicle colour wires with a multi-meter to ensure the correct function is identified before soldering or scotch locking. For vehicle wires denoted with two colours (example; RED/GREEN) the first colour will always be the main wire colour while the second colour is the thinner trace colour on the wire.

12. On the LHS of the cargo hold, remove the 6 screws using a Phillips head screwdriver (1).
13. Remove the access panel (2).

Repeat for the RHS.

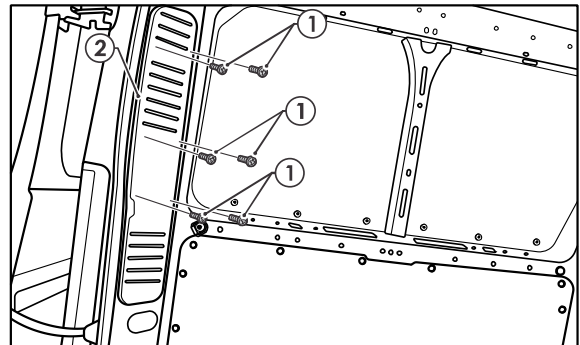

14. Inside the vehicle cabin, remove the 10 roof trim (1) screws (2).

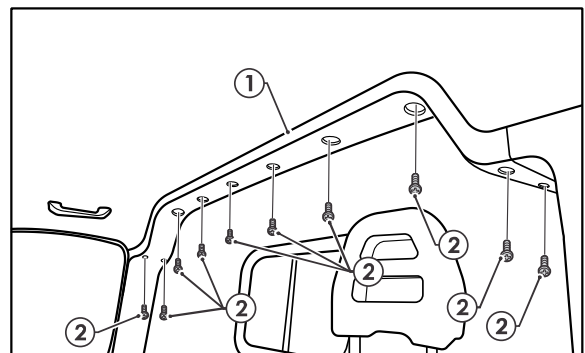

15. On the LHS of the passenger door step area, remove the 10 screws (1).
16. Remove the door step trim (2).

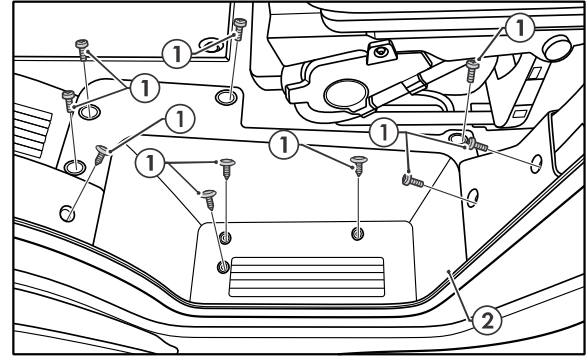

17. On the rear passenger side, remove the 6 screws (1) on the battery cover/lid (2).
18. Remove the battery cover/lid (2).

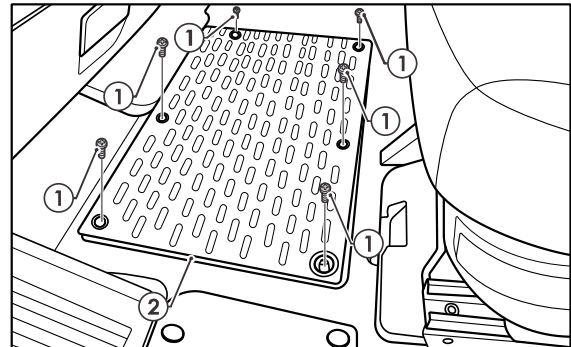

19. On the RHS 'C' pillar cavity, locate the tail light assembly connectors (1).
20. Disconnect the tail light connectors (1) and connect the RHS trailer patch (102286-WL) 8-way connector (2).
21. Route the RPA 6-way connector down the C-pillar & patch into vehicle side.
22. Connect the 3-way connector on the RHS patch to the mating 3-way connector on the main harness.
23. Route the trailer patch main harness (3) up through the 'C' pillar towards the LHS of the vehicle.

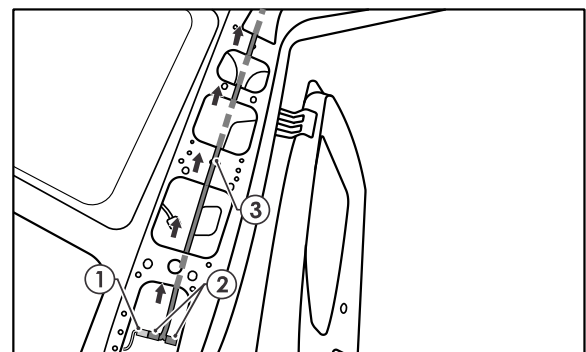

Note: The RPA Connector 6-way female side will be connected once the bumper fascia is replaced.

24. Continue routing the trailer patch (1) inside the roof cavity (2)

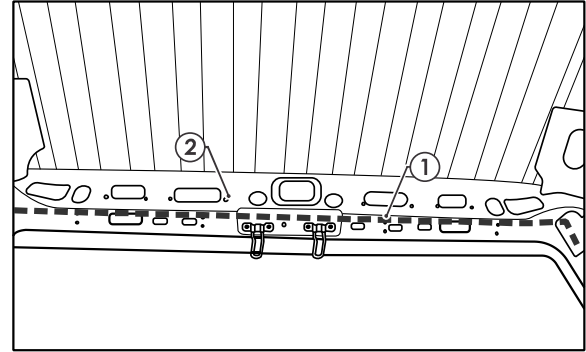

25. On the LHS of the 'C' pillar cavity, locate the tail light assembly connectors (1).
26. Disconnect the tail light assembly connectors (1) and connect the trailer patch 8-way connectors (2).

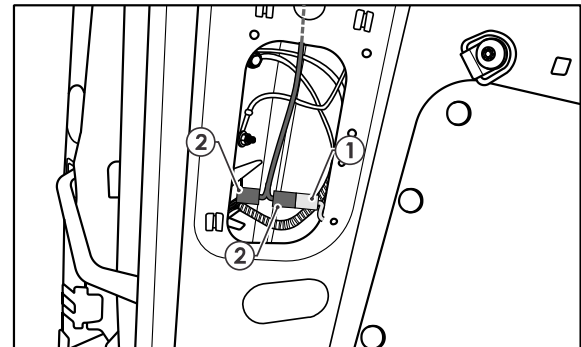

27. Inside the luggage compartment access panel, apply double sided tape to the ECU (1) and secure it to the vehicle sheet metal in the area shown.
28. Connect the trailer patch 12-way connector (2) to the ECU (1).

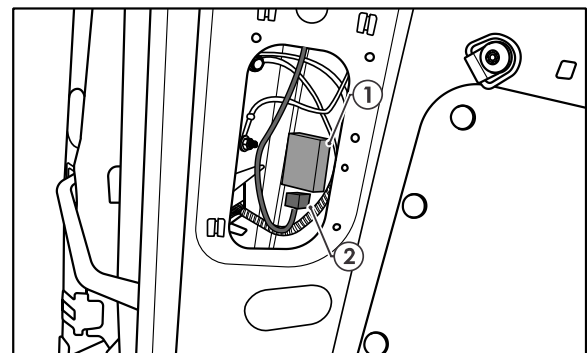

Note: Ensure ECU connector is facing downwards.



TOWBAR INSTALLATION INSTRUCTIONS

PART NUMBER 03327RW

FIAT DUCATO SERIES 6 CL4

29. Connect the trailer patch ring terminal (1) to the existing vehicle grounding point (2).

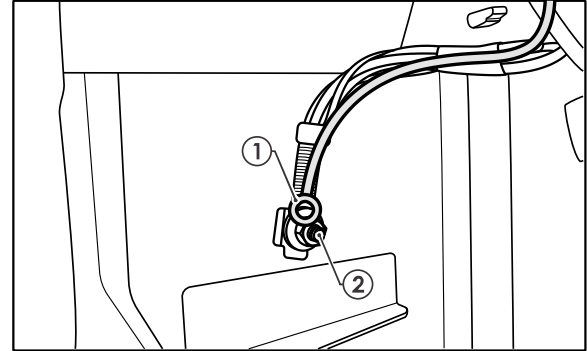

30. Connect the power harness 1-way connector (1) to the trailer patch 1-way breakout connector (2).
31. Route the power harness (3) towards the front of the vehicle.

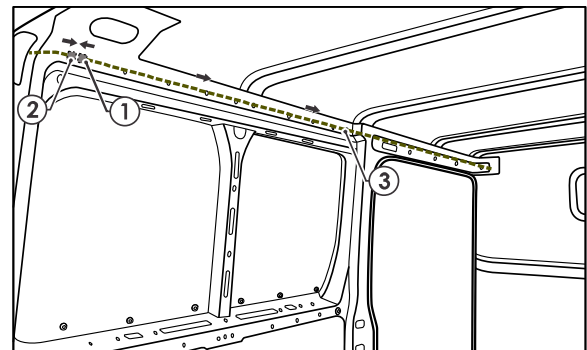

32. Using the existing vehicle harness, continue to feed the power harness (1) through the previously removed panel in front of the vehicle cabin area.
33. Connect the power harness (1) to the positive side of the battery (2).

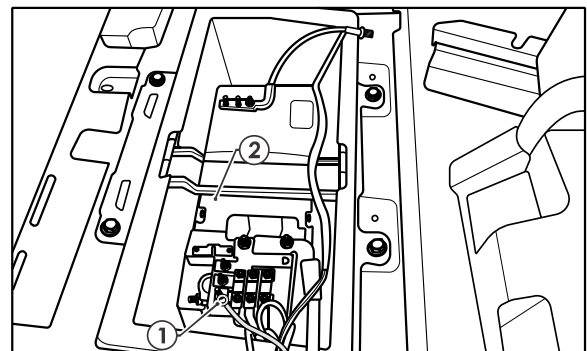



TOWBAR INSTALLATION INSTRUCTIONS

PART NUMBER 03327RW

FIAT DUCATO SERIES 6 CL4

34. With the rear bumper removed, secure tail harness to towbar
35. On the LHD, Route tail harness up through square vehicle grommet hole towards the blue connector on the patch loom.

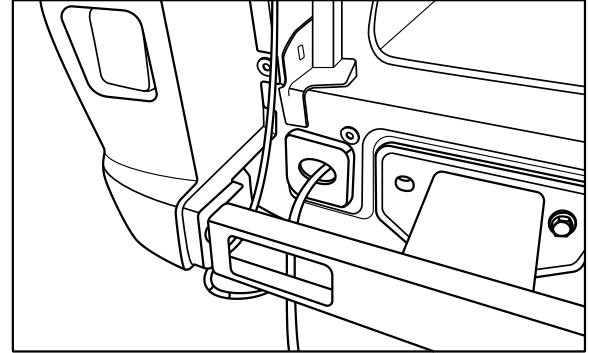

36. Connect the tail harness (tail length 1800mm) 8way connector (1) to the trailer patch mating 8way connector (2).
37. Cut-off, crimp the tail harness GREY and GREY/BLACK wires (3) to the trailer patch matching GREY and GREY/BLACK wires (4).

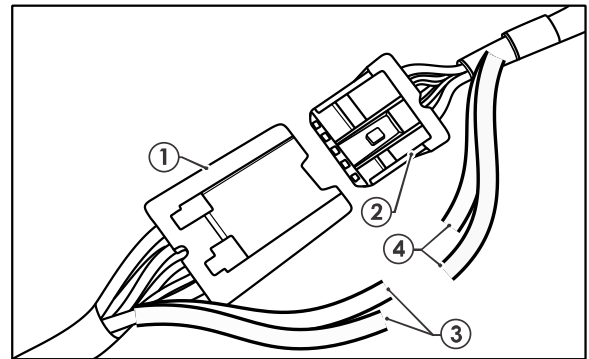

38. Secure all harness using supplied Cable Ties.
39. Test the trailer patch function using a light board or multi-meter.
40. Re-fit all removed parts and secure all fasteners, ensuring there are no squeaks or rattles.
41. Place the fitting instructions in the glove box after fitment.

42. Refit the bumper and spare wheel.

At an appropriate position, mark out and drill 2x \varnothing 5mm holes 69mm apart on bumper skin to support plug bracket.

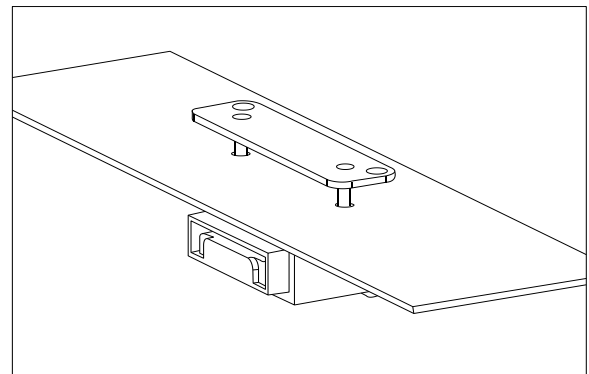



CUSTOMER INFORMATION

PLACE THESE INSTRUCTIONS IN THE
VEHICLE'S GLOVEBOX AFTER INSTALLATION

**THANK YOU FOR PURCHASING HAYMAN REESE.
WITH CORRECT MAINTENANCE AND CARE THIS PRODUCT WILL PROVIDE A
LIFETIME OF TROUBLE-FREE OPERATION.**

i TOWBAR MAINTENANCE AND CARE:

1. Hayman Reese recommend that the towbar LUG or TBM (tow ball Mount) Pull Pin and R-clip are removed and stored when not in use. Removal of LUG or TBM (tow ball mount) is advisable when not in use to assist with any of the following.
 - Ensure rear number plate is not obscured.
 - Allow maximum available departure angle and prevent any potential interference.
 - Prevent possible interference with vehicles reverse sensors or camera detecting a tow ball mount as an obstruction during reversing.
 - Removes towball mount as an obstruction for when moving around the rear of the vehicle.
2. Hayman Reese recommends routine inspection of your towbar to ensure trouble free towing.
 - Bolt security and tension should be regularly inspected and checked for correct tension. Replace any worn or defective parts with suitable grade & class fasteners. Inspection should be requested to coincide with vehicle major services.
3. It is the owner's responsibility to ensure towing and down ball weight capacities of the towing vehicle are not exceeded.
 - Towing and down ball weights allowable may differ according to model variations. Please refer to owner's manual or vehicle dealer to confirm exact rating for your vehicle model variant.
 - It is not uncommon for the vehicle tow rating to differ from the towbar rating. When this occurs, the lesser rating must be adhered to.
 - For vehicles fitted with enhanced vehicle functions that may be altered/changed when towing i.e Trailer sway mitigation, blind spot detection, adaptive cruise control etc. Please consult owner's manual to understand changes enabled when towing and after towing.

i WARRANTY INFORMATION:

Hayman Reese Towbars are covered by a Lifetime Warranty.

Our goods come with guarantees that cannot be excluded under the Australian Consumer Law. You are entitled to a replacement or refund for a major failure and for compensation for any other reasonably foreseeable loss or damage. You are also entitled to have the goods repaired or replaced if the goods fail to be of acceptable quality and the failure does not amount to a major failure.

For further details please visit www.haymanreese.com.au/warranty or contact customer service on 1800 812 017 or info@haymanreese.com.au.



CUSTOMER INFORMATION

PLACE THESE INSTRUCTIONS IN THE VEHICLE'S GLOVEBOX AFTER INSTALLATION

HAYMAN REESE SMART PIN

Your Hayman Reese towbar is equipped with Smart Pin technology to help reduce towbar tongue rattle in most driving conditions. Please ensure below instructions are understood and routine maintenance is carried out to ensure best towing experience.

i Regularly inspect for wear and check the tightness of the Smart Pin Nut. Follow instructions below to re-tighten the nut as necessary when movement and noise in the tow ball mount is noted.

- Before towing, ensure R-Clip is properly installed and Smart pin nut is installed and tensioned. Replacement parts are available from your Hayman Reese Distributor.

TOWBALL MOUNT REMOVAL/INSTALLATION

STEP 1

Insert Trailer Ball Mount (TBM) (a) into towbar hitchbox (b), aligning hole in TBM shank (c) with hole in hitchbox (d) (Fig. 1)

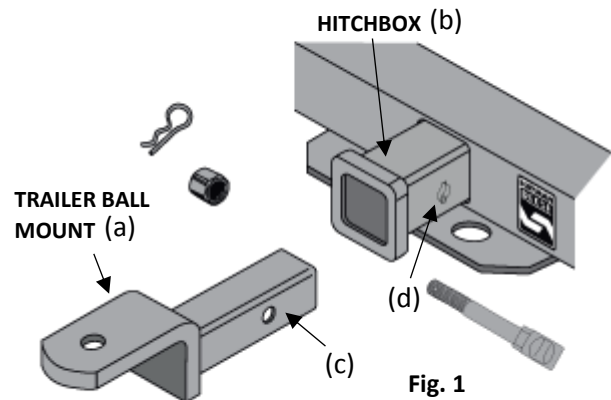

STEP 2

Insert Smart Pin (e) through hole in hitchbox and hole in TBM shank (g); ensure the locators are inserted into the notches in the hitchbox (Fig. 2)

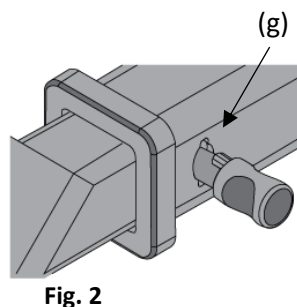

STEP 3

Screw Smart Pin Nut (f) onto Smart Pin (g); tighten Smart Pin Nut until finger tight, ensuring TBM is restrained from up and down movement.

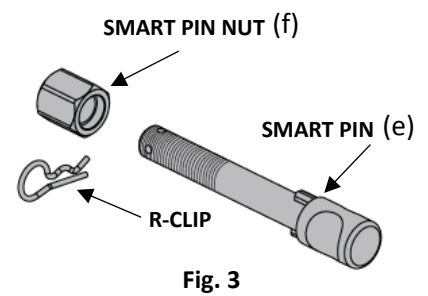

STEP 4

Tighten Smart Pin Nut by turning nut a further 1/8th of a turn in the clockwise direction using a 24mm spanner (Fig. 4).

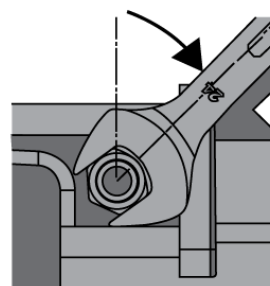

STEP 5

Install Smart Pin R-Clip through the hole that provides best clearance or easiest access. (Fig. 5)

