



# TOWBAR INSTALLATION INSTRUCTIONS

PART NUMBER 03378RW

MERCEDES GLC X253 MY20 CLASS 4



## PRODUCT DETAILS:

Part Number:	03378RW	Maximum Towing Braked:	2400	kg
ECU Number:	WLE70021	Maximum Towing Unbraked:	750	kg
Tail Harness Length Required:	1200 mm	Maximum Static Ball Load:	240	kg
TBM/Lug Part Number:	21325			

## FITTING DETAILS:

Towbar Installation Time:	120 Mins.	Hayman Reese SmartCODE Solution Required:	YES
Wiring Installation Time:	40 Mins.	RPA Disable/Other:	YES
Total Installation Time:	160 Mins.		
Bumper Cut Required:	Yes		

### Notes:

- Electric Brake = Brake prep connector position (F).
- Please refer vehicles owner's manual for proper operation and understanding of towing features enabled when coded.
- Remote tailgate opener (foot swipe) is no longer available once towbar is fitted.  
(see Appendix A for added information)



# TOWBAR INSTALLATION INSTRUCTIONS

PART NUMBER 03378RW

MERCEDES GLC X253 MY20 CLASS 4

**ENSURE THAT INSTRUCTIONS ARE UNDERSTOOD PRIOR TO FITMENT.**

## **i** BEFORE YOU START:

Hayman Reese recommends that instructions are read completely prior to fitment. Check all hardware items have been included refer to assembly diagram. Please ensure this towbar is only fitted to vehicle models as per Hayman Reese application guide ([www.haymanreese.com.au](http://www.haymanreese.com.au)).

### Bumper Cuts



Vehicle and bumper variations can and do occur during vehicle manufacture after initial towbar design. Fitment of towbar to vehicle and accuracy of bumper cut must be assessed prior to any bumper modifications made. Incorrect bumper cuts are not covered under Hayman Reese warranty.

**NOTE: Bumper cuts need to be approached with care, refer to notes below.**

- Bumper centreline – where the centreline of the bumper needs to be determined, the installer must assess centre point by measurement of bumper width or determining two symmetrical reference points to give centreline.
- Bumper edge – To assist with accurate bumper cut measurement, reference to the start of the bumper edge is now being commonly used.
  - Measure from bottom edge along bumper and around corner to the 70 mm point (Figure 1).
  - Do not measure from visible bumper front of corner, upwards (Figure 2).

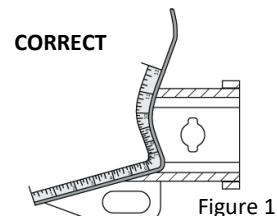

Figure 1

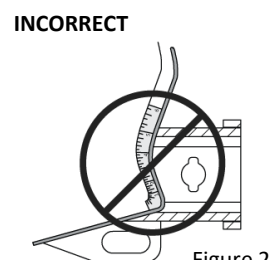

Figure 2

### Drilling

- For any required drilling during installation, ensure that the area is clear of fuel, electrical & other components that may be damaged.
- All holes drilled into the body panels shall have all burrs & swarf removed then coated with a suitable rust preventative paint.

### Bolts/Fasteners

- Ensure that all hardware is fastened to correct torque as specified in this fitting instruction.
- All fasteners supplied with this product are used to achieve a specified clamp loading. If replacement is required ensure that fasteners of the same grade and class are used.



**NOTE: Achieving correct torque is critical to proper installation and responsibility of the installer. Towbar failures attributed to tension issues from over tightening or under tightening are not covered by Hayman Reese warranty.**

### Product Labels

- a. Towbar load rating sticker provided with this product shall be conspicuously located on inside rear end of the driver's door.
- b. Powertrain Control Module (PCM)/Body Control Module (BCM) upgrade warning label will be provided in towbar kit for vehicles as required. Affix warning label in door and owner's handbook.

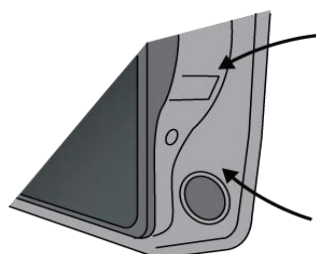

Place **Load Rating sticker** inside driver's door here

Place **Vehicle PCM/ BCM upgrade warning label** in door AND on front cover of owner's service handbook

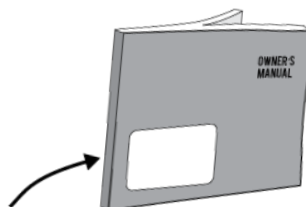

## **WARNING:**

**Do not, drill, cut, weld or otherwise modify the towbar.**

**FOR TOWING PURPOSES ONLY - This towbar is designed and tested by Hayman Reese to adhere to ADR 62/02 which provides only for the expected load demands of towing.**



# TOWBAR INSTALLATION INSTRUCTIONS

PART NUMBER 03378RW

MERCEDES GLC X253 MY20 CLASS 4

## TOWBAR ASSEMBLY DIAGRAM

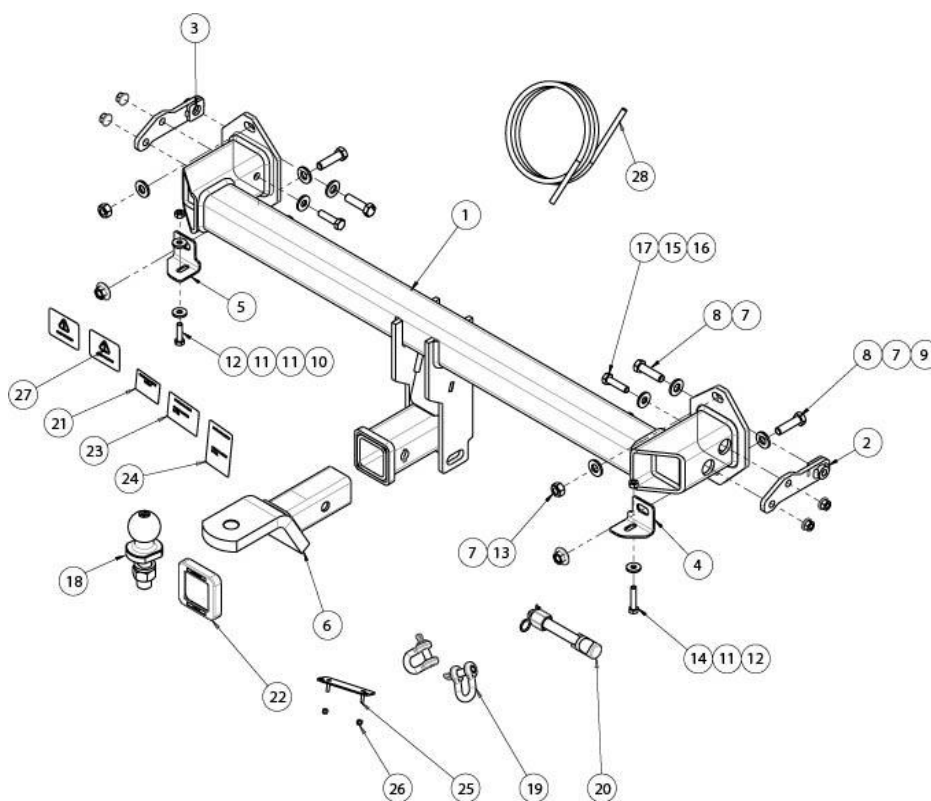

ITEM	DESCRIPTION	QTY
1	MERCEDES-BENZ GLC WELDED ASSY	1
2	CHASSIS INSERT RHS WELDED ASSY	1
3	CHASSIS INSERT LHS WELDED ASSY	1
4	SUPPORT TAB RHS	1
5	SUPPORT TAB LHS	1
6	TRAILER BALL MOUNT	1
7	WASHER PLAIN 1/2"	6
8	SET SCREW HEX HD M12x45x1.25P	4
9	NUT HEX HD FLANGED M12x1.25P	2
10	SET SCREW HEX HD M8x30x1.25P	1
11	WASHER PLAIN M8x22x3	3
12	NUT HEX HD M8x1.25P	2
13	NUT HEX HD M12x1.5P	2
14	BOLT HEX HD M8x40x1.25P	1

ITEM	DESCRIPTION	QTY
15	WASHER PLAIN M10x25x3	4
16	NUT HEX HD M10x1.25P	4
17	BOLT HEX HD M10x40x1.25P	4
18	TOWBALL 50mm	1
19	"D" SHACKLE 10mm	2
20	SMART PIN GOLD	1
21	H.R STICKER	1
22	HITCH BOX COLLAR COVER	1
23	COMPLIANCE LABEL	1
24	DOOR RATING LABEL	1
25	PLUG BRACKET	1
26	NUT NYLOC HEX HD M4x0.7P	2
27	CAN MODULE WARNING LABEL	2
28	WIRE LOOM	1



# TOWBAR INSTALLATION INSTRUCTIONS

PART NUMBER 03378RW

MERCEDES GLC X253 MY20 CLASS 4

## WIRING ASSEMBLY DIAGRAM

### Electrical wiring layout

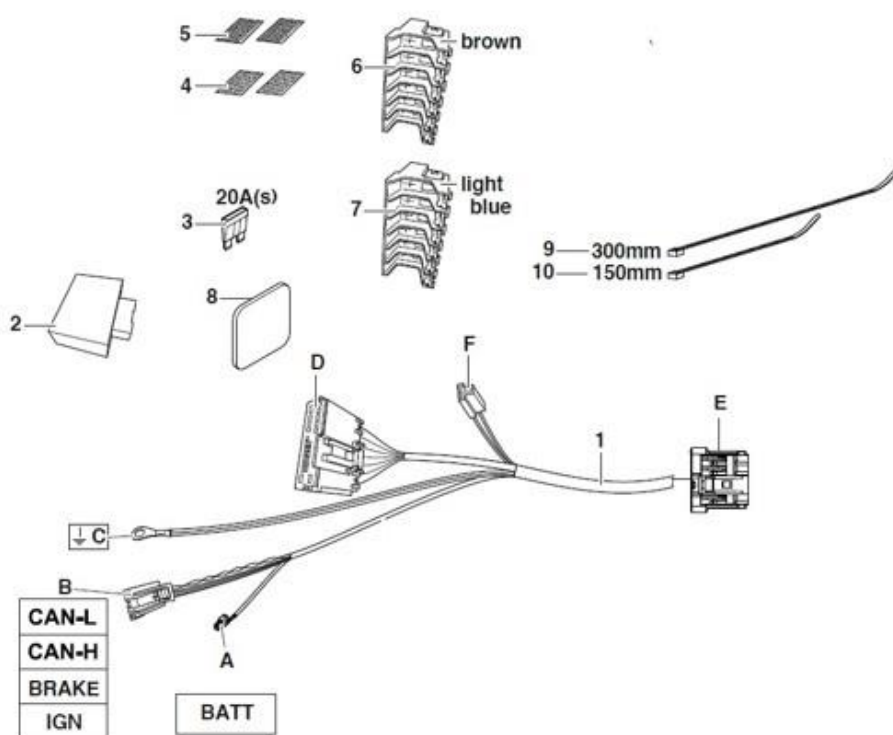

ITEM	DESCRIPTION	QTY
1	WLL90021 TRAILER PATCH	1
2	TRAILER MODULE (WLE70021)	1
3	20amp FUSE	1
4	HOOK TAPE	2
5	LOOP TAPE	2
6	BROWN FUSE HOLDER (NOT REQUIRED)	1
7	LIGHT BLUE FUSE HOLDER (NOT REQUIRED)	1
8	FOAM PAD	2
9	300mm CABLE TIE	3
10	150mm CABLE TIE	5



# TOWBAR INSTALLATION INSTRUCTIONS

PART NUMBER 03378RW

MERCEDES GLC X253 MY20 CLASS 4

1. Release tailgate to expose boot cabin.

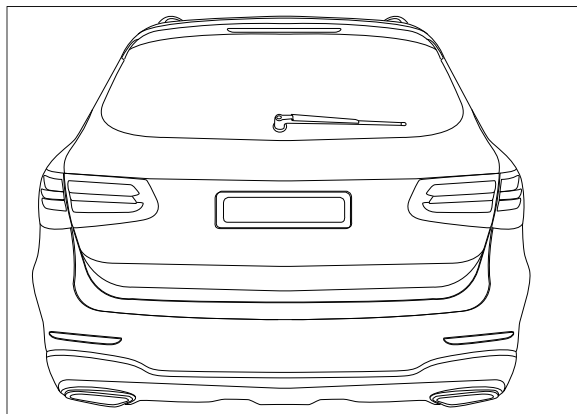

2. Remove the boot tray from the boot cabin.

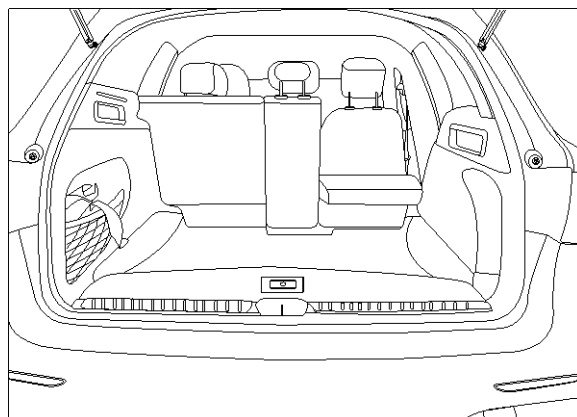

3. Remove 1x Torx Screw from the centre of the scuff plate to allow it to be detached (6x plastic retainer clips hold it in place).

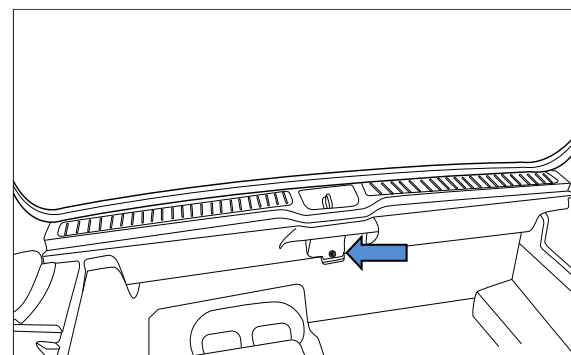



# TOWBAR INSTALLATION INSTRUCTIONS

PART NUMBER 03378RW

MERCEDES GLC X253 MY20 CLASS 4

4. Remove the 1x Interior Trim to provide access to the rear of the left hand side taillight assembly.

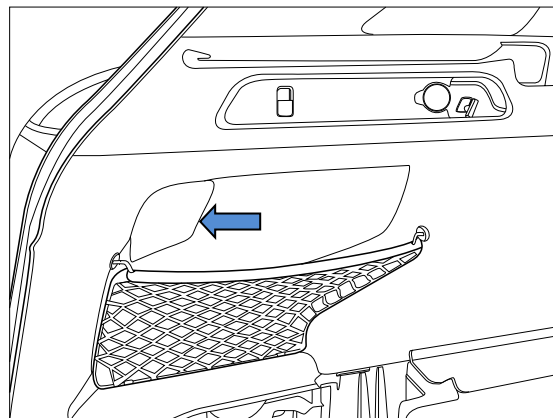

5. Remove the 2x Interior Trim to provide access to the rear of the right hand side taillight assembly.

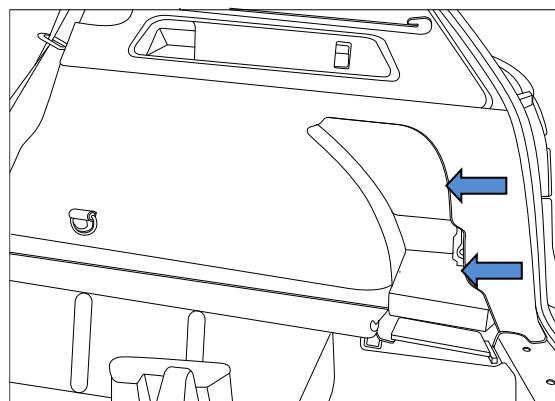

6. Remove the 2x Tie Down Bracket on the right-hand side. Lift plastic cover and remove 1x Torx Screw.

7. Dislodge the right-hand side Interior trim and disconnect the connector and back seat release. Then remove trim to access the rear SAM. (SIGNAL ACQUISITION MODULE)

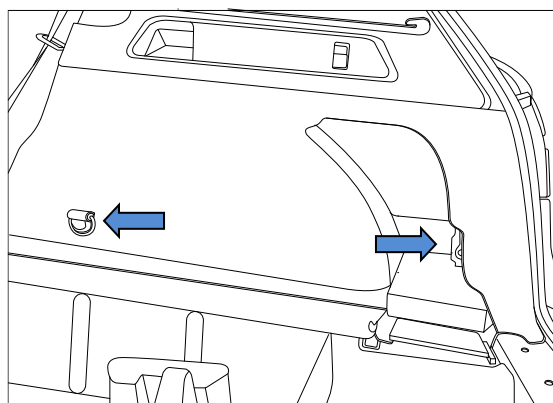



# TOWBAR INSTALLATION INSTRUCTIONS

PART NUMBER 03378RW

MERCEDES GLC X253 MY20 CLASS 4

8. Remove tail light assembly, secured from the inside with 3x Nuts. Disconnect the wiring harness.

Repeat for other side of the vehicle.

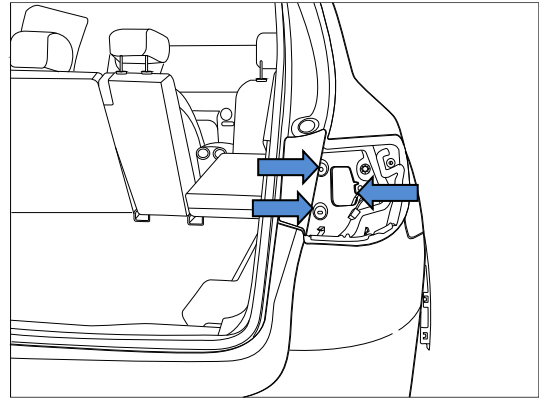

9. Remove the 4x Flanged Nuts inside the boot cavity on the rear face.

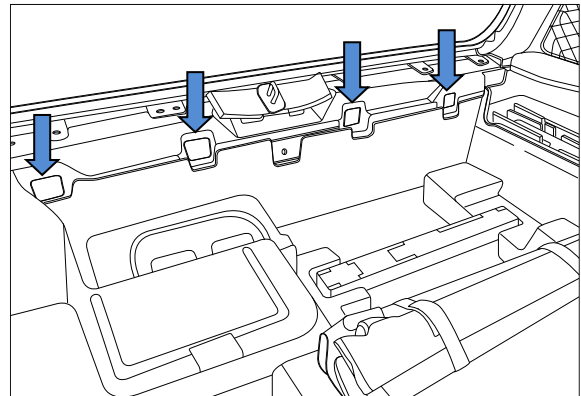

10. Remove boot interior, tools and accessories.

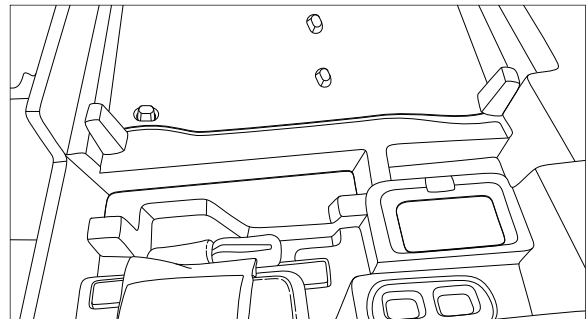



# TOWBAR INSTALLATION INSTRUCTIONS

PART NUMBER 03378RW

MERCEDES GLC X253 MY20 CLASS 4

11. Remove 4x Scrivets in rear wheel arch.

Repeat for other side of the vehicle.

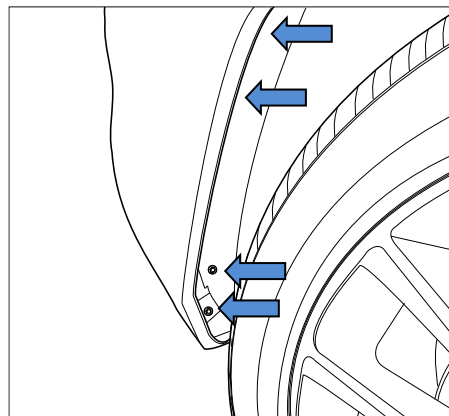

12. Remove the 1x Screw from the inside of the bumper at rear wheel well. Deflect the wheel arch trim out of the way to reveal this fastener.

Repeat for the other side of the vehicle.

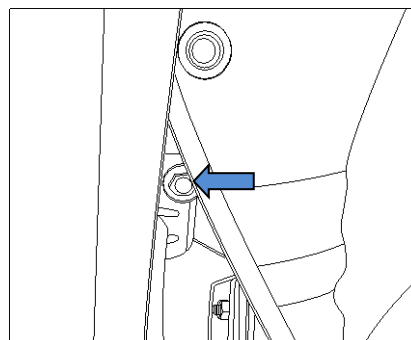

13. Remove 1x Scrivet from inside of the bumper at rear wheel well. Deflect the wheel arch trim out of the way to reveal this fastener.

Repeat for the other side of the vehicle.

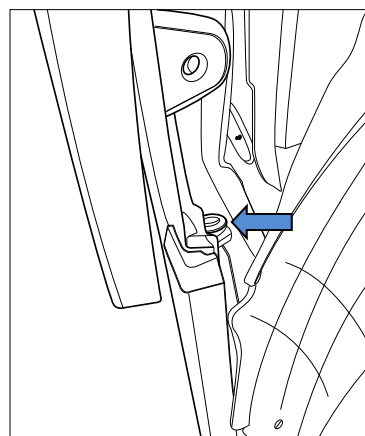



14. Remove 2x Screw on the underside of the wheel arch.

Repeat for the other side of the vehicle.

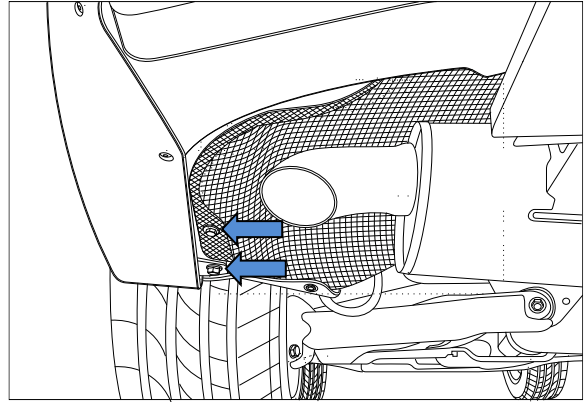

15. Remove 1x Screw on the underside of rear end of the bumper in the centre.

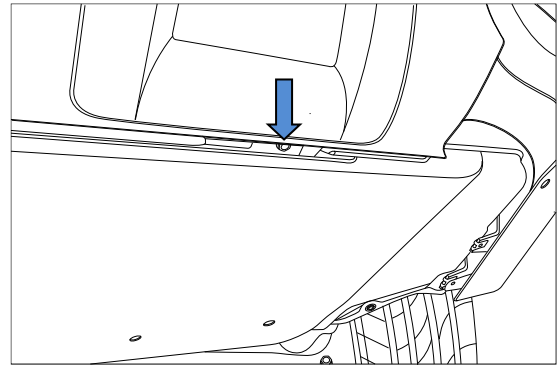

16. Remove 2x Screws on the underside rear end of the bumper that are located higher than the bottom of the bumper.

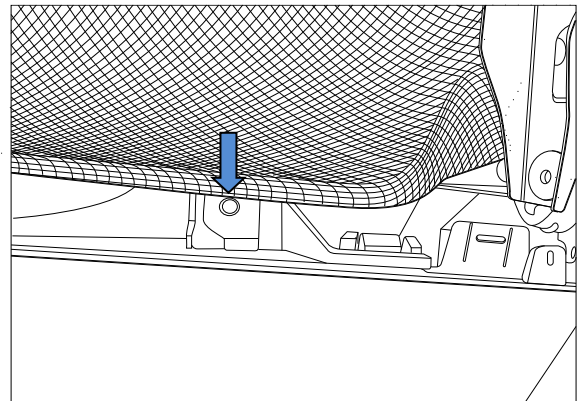



# TOWBAR INSTALLATION INSTRUCTIONS

PART NUMBER 03378RW

MERCEDES GLC X253 MY20 CLASS 4

17. Disconnect the wiring harness from within the boot cavity and peel back bumper from the vehicle. Set bumper safely aside.

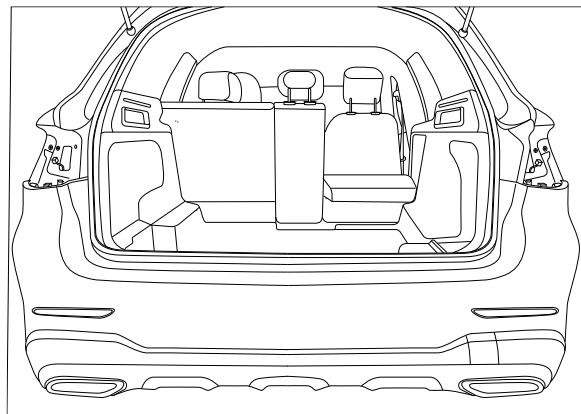

18. Remove and dispose of the screw securing the ad-blue tank (if fitted) on the right hand side of the vehicle. Temporarily support the weight of the ad-blue tank.

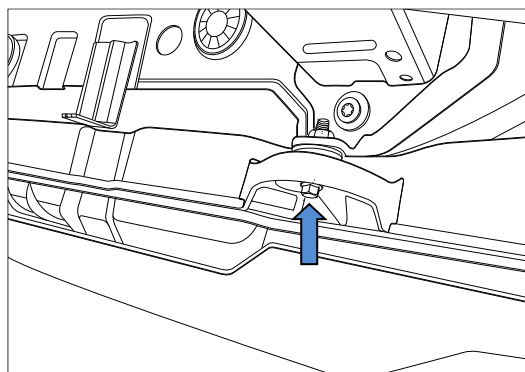

19. Remove and discard the screw securing the exhaust bracket to the impact beam on the left-hand side of the vehicle.

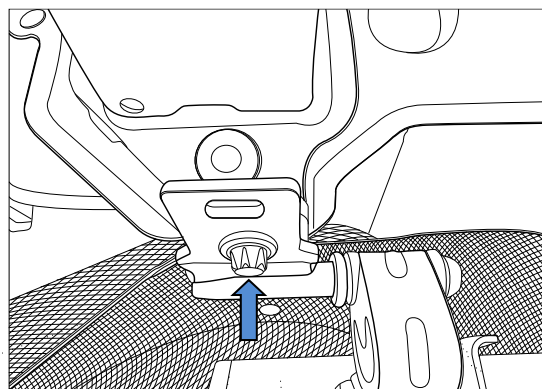



# TOWBAR INSTALLATION INSTRUCTIONS

PART NUMBER 03378RW

MERCEDES GLC X253 MY20 CLASS 4

20. Remove and discard the impact beam along with the sealing tape and 4x nuts securing the beam to the vehicle.

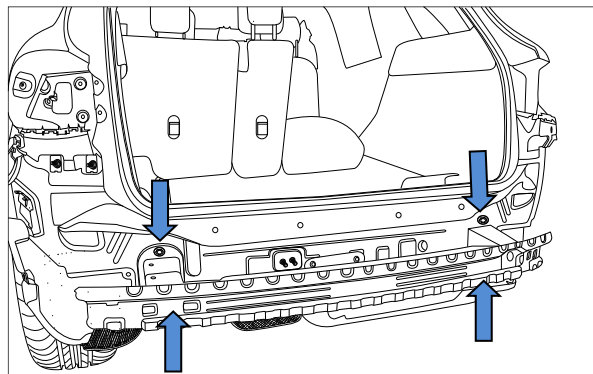

21. Using a step drill, drill a  $\varnothing 30\text{mm}$  hole where indicated on rear panel.

Remove any burrs or sharp edges from hole and cover exposed edges with a rust inhibitor.

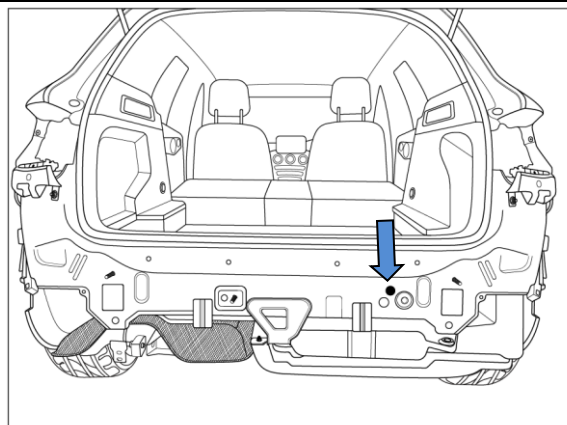

22. Insert the side arm into the chassis rail. The tapped nuts must be located facing outwards of the vehicle.

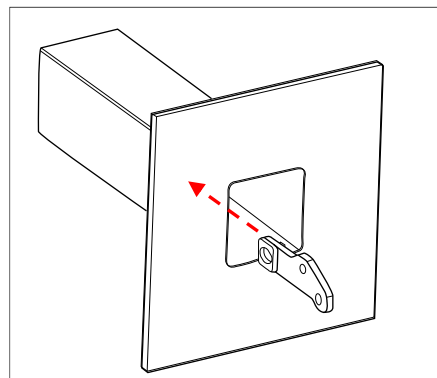



# TOWBAR INSTALLATION INSTRUCTIONS

PART NUMBER 03378RW

MERCEDES GLC X253 MY20 CLASS 4

23. From inside the luggage well, loosely secure the side arm with 1x M12 x 1.25P x 45 bolt complete with 1x Washer.

Repeat for other side of vehicle.

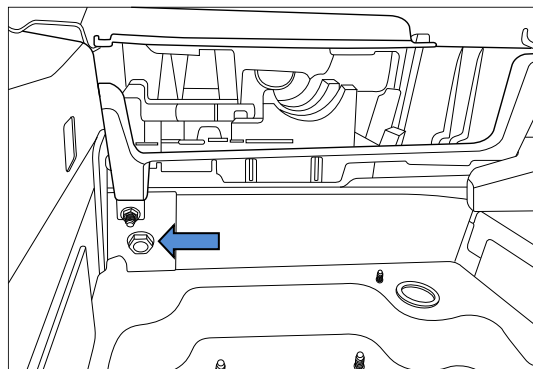

24. Loosely secure the bottom of the Towbar to the rear panel along with the Support Tabs using 1x M12 x 1.25P x 45 bolt complete with 1x Washer and 1x M12 Flanged Nut.

Repeat for the other side of the vehicle.

25. Loosely secure the top of the Towbar to the rear panel 1x M12 x 1.5P Nut complete with 1x Washer.

Repeat for the other side of the vehicle.

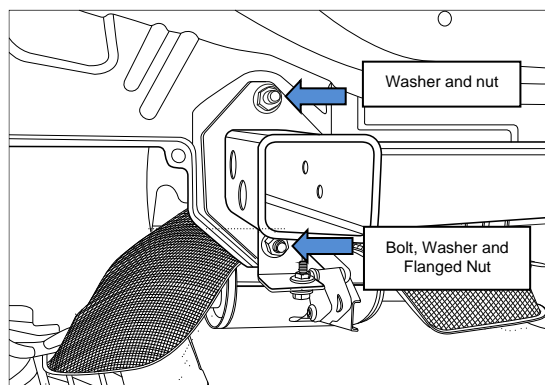

26. Secure the side arm to the Towbar using 2x M10 x 1.25P x 40 bolts complete with 1x Washers and 1x M10 Flanged Nut per bolt.

Repeat for other side of the vehicle.

**Note:** Plate not shown in tube cavity for clarity of instructions.

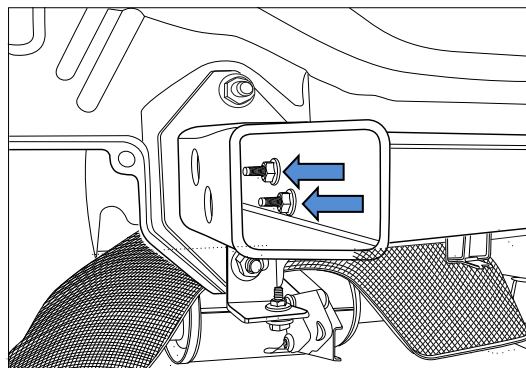



# TOWBAR INSTALLATION INSTRUCTIONS

PART NUMBER 03378RW

MERCEDES GLC X253 MY20 CLASS 4

27. Torque all fasteners to the following specifications:

M12 x 1.25 x 45: 125 Nm (step 23 and 24).

M12 x 1.5: 83 Nm (step 25)

M10 x 1.25 x 40: 68 Nm (step 26)

28. Peel the backing off the 3M sticker and place over the two exposed holes (make sure the surface is clean). Silicon around the outside of the mounting flange to complete the seal (as marked by the dotted line).

Repeat for the opposite side of the vehicle.

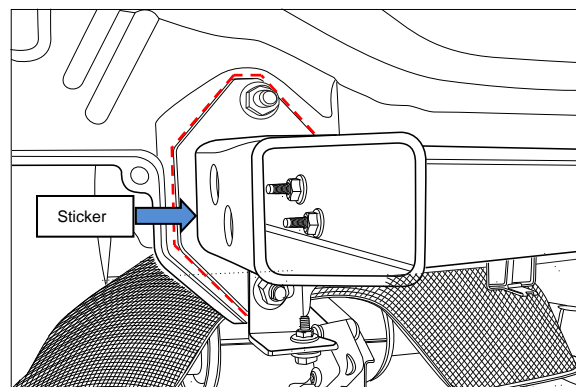

29. Secure the exhaust bracket to the support tab using 1x M8 x 1.25 x 30 bolt complete with 2x Washers and M8 nut.

**Torque the bolt to 22 Nm.**

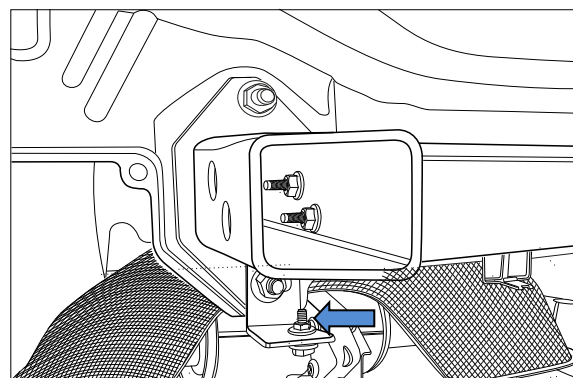



# TOWBAR INSTALLATION INSTRUCTIONS

PART NUMBER 03378RW

MERCEDES GLC X253 MY20 CLASS 4

30. Secure the ad-blue tank to the support tab using 1 x M8 x 1.25 x 40 bolt complete with 1x Washer on the bottom and M8 nut.

**Torque the bolt to 22 Nm.**

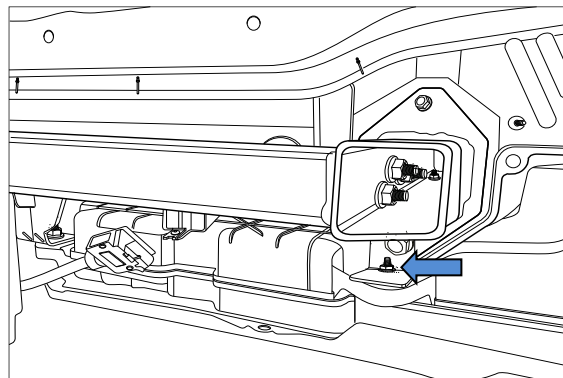

31. Disconnect and dispose of the hands free foot swipe for the tailgate by unclipping it in four places and disconnecting the wiring harness.

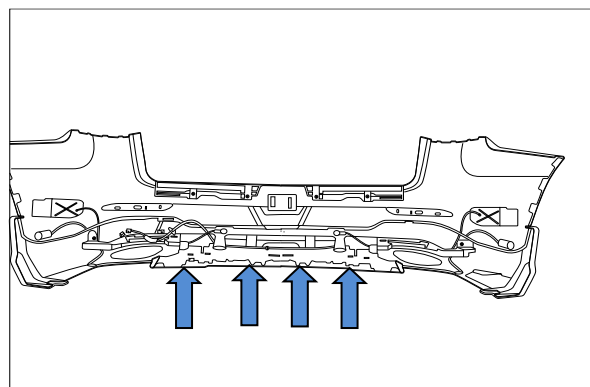

32. Identify the centreline of the bumper and create bumper cut 90 mm x 160 mm starting at the bottom edge as measured on the inside of the bumper.

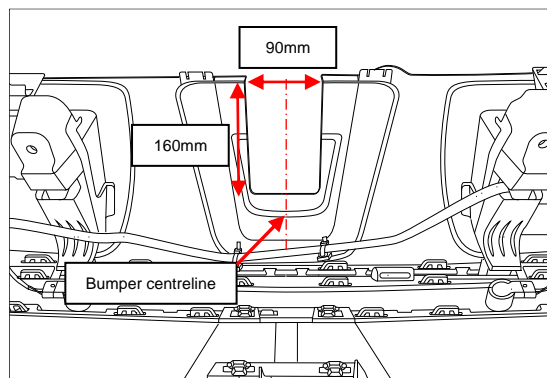

33. Route the harness as shown, locate the factory earth stud and connect the GND ring terminal (C). Plug the ECU into 14-way connector (I) clean the area where the ECU will be mounted pick the backing off and adhere the ECU to the Sheetmetal. Route the 4-way CAN connector (B) towards the rear SAM and plug the in the connector.

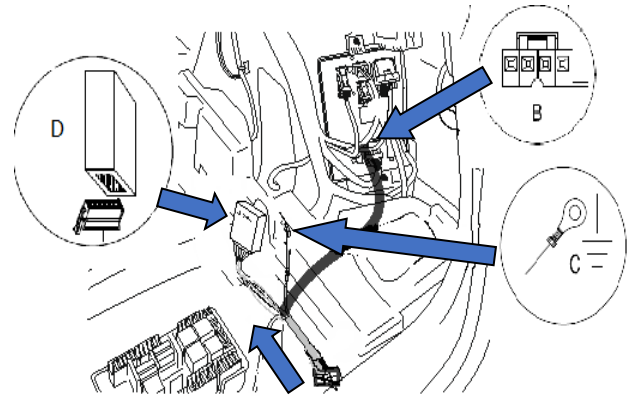

34. Route the RED/BLUE (A) wire toward the rear main fuse box and remove the blue fuse holder (F407) by releasing the side tabs using a thin flat blade screw driver.

Insert the RED/BLUE wire (A) into fuse cavity F407 then reinsert the fuse holder back in to the main fuse box.

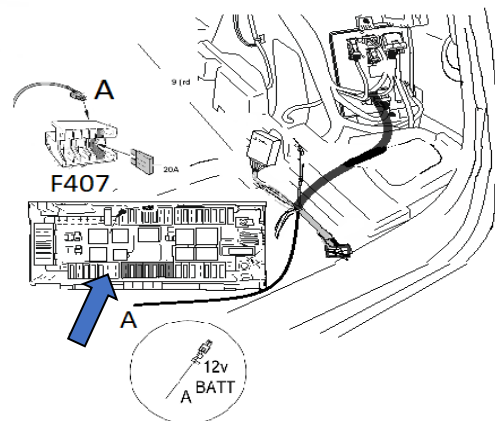

35. Route the trailer tail harness (tail length 1200mm) through the previously drilled hole adjust the grommet to length ensure that the grommet is seated properly and secure with a cable (not supplied) inside the vehicle connect the tail 8-way male connector to the 8-way female connector (D).

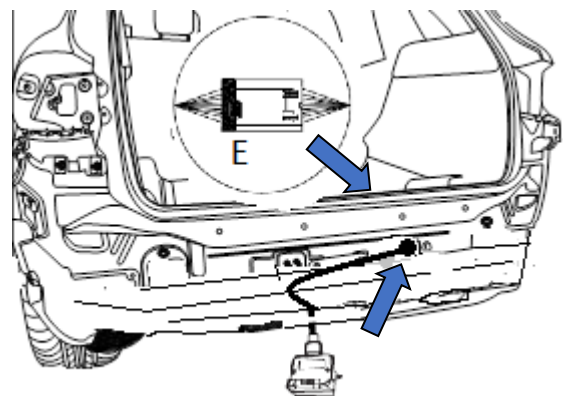



# TOWBAR INSTALLATION INSTRUCTIONS

PART NUMBER 03378RW

MERCEDES GLC X253 MY20 CLASS 4

---

36. At an appropriate position on the bumper, mark out and drill 2x  $\varnothing$ 5mm holes 69mm apart on bumper skin to support plug bracket. Feed bracket threads through drilled holes prior to reinstalling bumper.

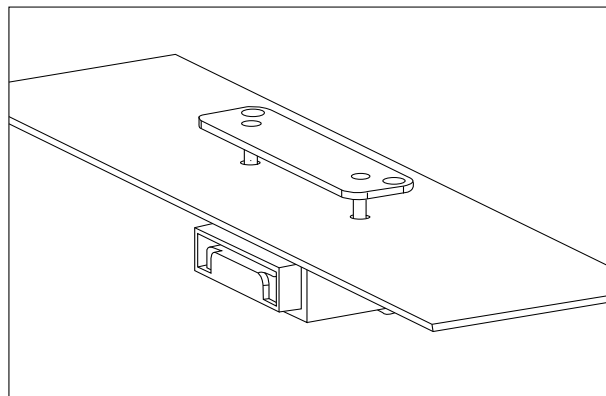

---

37. Reinstall bumper by following steps 1-17 in reverse order.

38. Next step is coding of vehicle. Pay attention to the "SmartCode" instruction (Appendix).

39. Check the operation of trailer lights and ensure that warning messages for the "RPA and Blind Spot Assist (BSD) not available" come up on the dash when trailer is connected then click ok for acknowledgment.

When the trailer is disconnected RPA & BSD will be active again once the brake pedal is pressed.

40. Place fitting instruction in the glove box after fitment.

---





# CUSTOMER INFORMATION

PLACE THESE INSTRUCTIONS IN THE  
VEHICLE'S GLOVEBOX AFTER INSTALLATION

**THANK YOU FOR PURCHASING HAYMAN REESE.  
WITH CORRECT MAINTENANCE AND CARE THIS PRODUCT WILL PROVIDE A  
LIFETIME OF TROUBLE-FREE OPERATION.**

## **i** TOWBAR MAINTENANCE AND CARE:

1. Hayman Reese recommend that the towbar LUG or TBM (tow ball Mount) Pull Pin and R-clip are removed and stored when not in use. Removal of LUG or TBM (tow ball mount) is advisable when not in use to assist with any of the following.
  - Ensure rear number plate is not obscured.
  - Allow maximum available departure angle and prevent any potential interference.
  - Prevent possible interference with vehicles reverse sensors or camera detecting a tow ball mount as an obstruction during reversing.
  - Removes towball mount as an obstruction for when moving around the rear of the vehicle.
2. Hayman Reese recommends routine inspection of your towbar to ensure trouble free towing.
  - Bolt security and tension should be regularly inspected and checked for correct tension. Replace any worn or defective parts with suitable grade & class fasteners. Inspection should be requested to coincide with vehicle major services.
3. It is the owner's responsibility to ensure towing and down ball weight capacities of the towing vehicle are not exceeded.
  - Towing and down ball weights allowable may differ according to model variations. Please refer to owner's manual or vehicle dealer to confirm exact rating for your vehicle model variant.
  - It is not uncommon for the vehicle tow rating to differ from the towbar rating. When this occurs, the lesser rating must be adhered to.
  - For vehicles fitted with enhanced vehicle functions that may be altered/changed when towing i.e Trailer sway mitigation, blind spot detection, adaptive cruise control etc. Please consult owner's manual to understand changes enabled when towing and after towing.

## **i** WARRANTY INFORMATION:

Hayman Reese Towbars are covered by a Lifetime Warranty.

Our goods come with guarantees that cannot be excluded under the Australian Consumer Law. You are entitled to a replacement or refund for a major failure and for compensation for any other reasonably foreseeable loss or damage. You are also entitled to have the goods repaired or replaced if the goods fail to be of acceptable quality and the failure does not amount to a major failure.

For further details please visit [www.haymanreese.com.au/warranty](http://www.haymanreese.com.au/warranty) or contact customer service on 1800 812 017 or [info@haymanreese.com.au](mailto:info@haymanreese.com.au).



# CUSTOMER INFORMATION

PLACE THESE INSTRUCTIONS IN THE VEHICLE'S GLOVEBOX AFTER INSTALLATION

## HAYMAN REESE SMART PIN

Your Hayman Reese towbar is equipped with Smart Pin technology to help reduce towbar tongue rattle in most driving conditions. Please ensure below instructions are understood and routine maintenance is carried out to ensure best towing experience.

**i** Regularly inspect for wear and check the tightness of the Smart Pin Nut. Follow instructions below to re-tighten the nut as necessary when movement and noise in the tow ball mount is noted.

- Before towing, ensure R-Clip is properly installed and Smart pin nut is installed and tensioned. Replacement parts are available from your Hayman Reese Distributor.

## TOWBALL MOUNT REMOVAL/INSTALLATION

### STEP 1

Insert Trailer Ball Mount (TBM) (a) into towbar hitchbox (b), aligning hole in TBM shank (c) with hole in hitchbox (d) (Fig. 1)

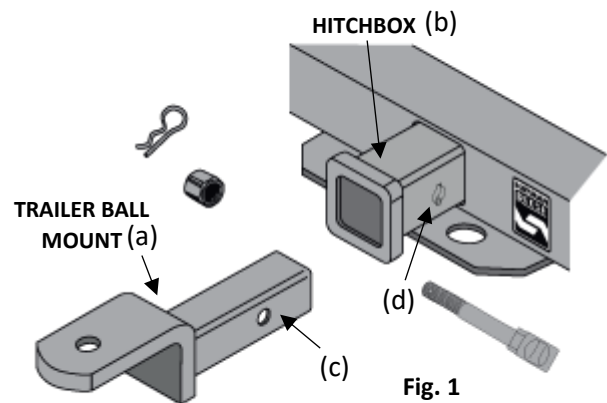

### STEP 2

Insert Smart Pin (e) through hole in hitchbox and hole in TBM shank (g); ensure the locators are inserted into the notches in the hitchbox (Fig. 2)

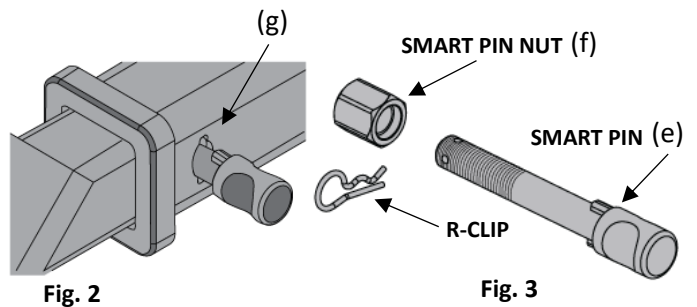

### STEP 3

Screw Smart Pin Nut (f) onto Smart Pin (g); tighten Smart Pin Nut until finger tight, ensuring TBM is restrained from up and down movement.

### STEP 4

Tighten Smart Pin Nut by turning nut a further 1/8th of a turn in the clockwise direction using a 24mm spanner (Fig. 4).

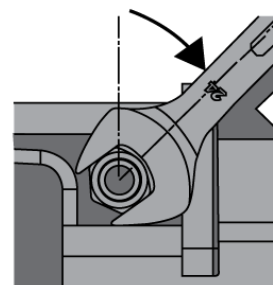

### STEP 5

Install Smart Pin R-Clip through the hole that provides best clearance or easiest access. (Fig. 5)



# Appendix



**WARNING:** This vehicle requires a system setting to ensure the trailer wiring and control module are correctly recognised. This process (referred to as 'coding') must be carried out to enable correct vehicle functionality when trailer is connected. Towing features enabled by correct control module and coding support OE functionality as set by OE manufacturer. Please read the vehicles owner's manual for proper operation and understanding.

Coding can be carried out using the Hayman Reese SmartCODE (HRSC) using the following steps. Note, if HRSC is unavailable, vehicle coding can be carried out by OE manufacturer as needed.

Before you start:

- **Ensure the HRSC software is up to date using the HAYMAN REESE SMARTCODE PC APP.**
  - **Ensure the vehicle battery is fully charged**
  - **Use of a battery support unit (BSU) is advised during the coding process.**
  - **Ensure towbar, wiring loom and ECU are correctly installed as per Hayman Reese fitting instructions.**
1. Locate the OBD2 port under the drivers footwell on the right-hand side and plug in the HRSC.
  2. Close all doors and turn the ignition on
  3. Follow the directions on the screen of the HRSC
  4. Once the vehicle has been coded successfully proceed to the "clear codes" tab
  5. Remove disconnect HRSC from OBD2 port.
  6. Check the dash to make sure there are no warning faults.
  7. Check the operation of trailer lights and ensure the Reverse Park Assist (RPA) is disabled and 'trailer on' icon is active where available.

For technical support and further information on Hayman Reese SmartCODE tool and coding process contact your nearest Hayman Reese stockist.

Australia: 1800 812 017

New Zealand: 0800 237 886