



# TOWBAR INSTALLATION INSTRUCTIONS

PART NUMBER 03418RW

MERCEDES SPR VAN VS30 RWD AWD



## PRODUCT DETAILS:

Part Number:	03418RW	Maximum Towing Braked:	2000	kg
ECU Number:	WLE70015	Maximum Towing Unbraked:	750	kg
Tail Harness Length Required:	1800 mm	Maximum Static Ball Load:	200	kg
TBM/Lug Part Number:	21161			
Wiring Part Number:	WLL90015			

## FITTING DETAILS:

Towbar Installation Time:	40 Mins.	Hayman Reese SmartCODE Solution Required:	YES
Wiring Installation Time:	60 Mins.	RPA Disable/Other:	YES
Total Installation Time:	100 Mins.		
Bumper Cut Required:	Yes		

### Note:

- Electric Brake = Brake Prep Connector
- Suits vehicles with OEM plastic rear step fitted. Please refer vehicles owner's manual for proper operation and understanding of towing features enabled when coded.



# TOWBAR INSTALLATION INSTRUCTIONS

PART NUMBER 03418RW

MERCEDES SPR VAN VS30 RWD AWD

**ENSURE THAT INSTRUCTIONS ARE UNDERSTOOD PRIOR TO FITMENT.**

## **i** BEFORE YOU START:

Hayman Reese recommends that instructions are read completely prior to fitment. Check all hardware items have been included refer to assembly diagram. Please ensure this towbar is only fitted to vehicle models as per Hayman Reese application guide ([www.haymanreese.com.au](http://www.haymanreese.com.au)).

### **Bumper Cuts**



Vehicle and bumper variations can and do occur during vehicle manufacture after initial towbar design. Fitment of towbar to vehicle and accuracy of bumper cut must be assessed prior to any bumper modifications made. Incorrect bumper cuts are not covered under Hayman Reese warranty.

**NOTE: Bumper cuts need to be approached with care, refer to notes below.**

- Bumper centreline – where the centreline of the bumper needs to be determined, the installer must assess centre point by measurement of bumper width or determining two symmetrical reference points to give centreline.
- Bumper edge – To assist with accurate bumper cut measurement, reference to the start of the bumper edge is now being commonly used.
  - Measure from bottom edge along bumper and around corner to the 70 mm point (Figure 1).
  - Do not measure from visible bumper front of corner, upwards (Figure 2).

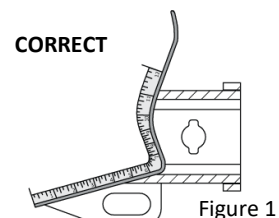

Figure 1

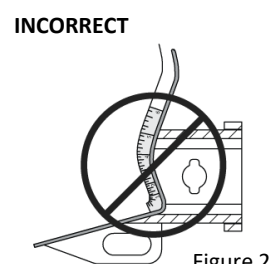

Figure 2

### **Drilling**

- For any required drilling during installation, ensure that the area is clear of fuel, electrical & other components that may be damaged.
- All holes drilled into the body panels shall have all burrs & swarf removed then coated with a suitable rust preventative paint.

### **Bolts/Fasteners**

- Ensure that all hardware is fastened to correct torque as specified in this fitting instruction.
- All fasteners supplied with this product are used to achieve a specified clamp loading. If replacement is required ensure that fasteners of the same grade and class are used.



**NOTE: Achieving correct torque is critical to proper installation and responsibility of the installer. Towbar failures attributed to tension issues from over tightening or under tightening are not covered by Hayman Reese warranty.**

### **Product Labels**

- a. Towbar load rating sticker provided with this product shall be conspicuously located on inside rear end of the driver's door.
- b. Powertrain Control Module (PCM)/Body Control Module (BCM) upgrade warning label will be provided in towbar kit for vehicles as required. Affix warning label in door and owner's handbook.

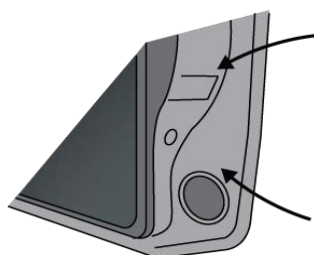

Place **Load Rating sticker** inside driver's door here

Place **Vehicle PCM/ BCM upgrade warning label** in door AND on front cover of owner's service handbook

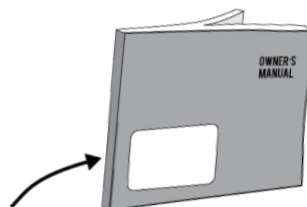

## **WARNING:**

**Do not, drill, cut, weld or otherwise modify the towbar.**

**FOR TOWING PURPOSES ONLY - This towbar is designed and tested by Hayman Reese to adhere to ADR 62/02 which provides only for the expected load demands of towing.**



# TOWBAR INSTALLATION INSTRUCTIONS

PART NUMBER 03418RW

MERCEDES SPR VAN VS30 RWD AWD

## **i** TOWBAR ASSEMBLY DIAGRAM

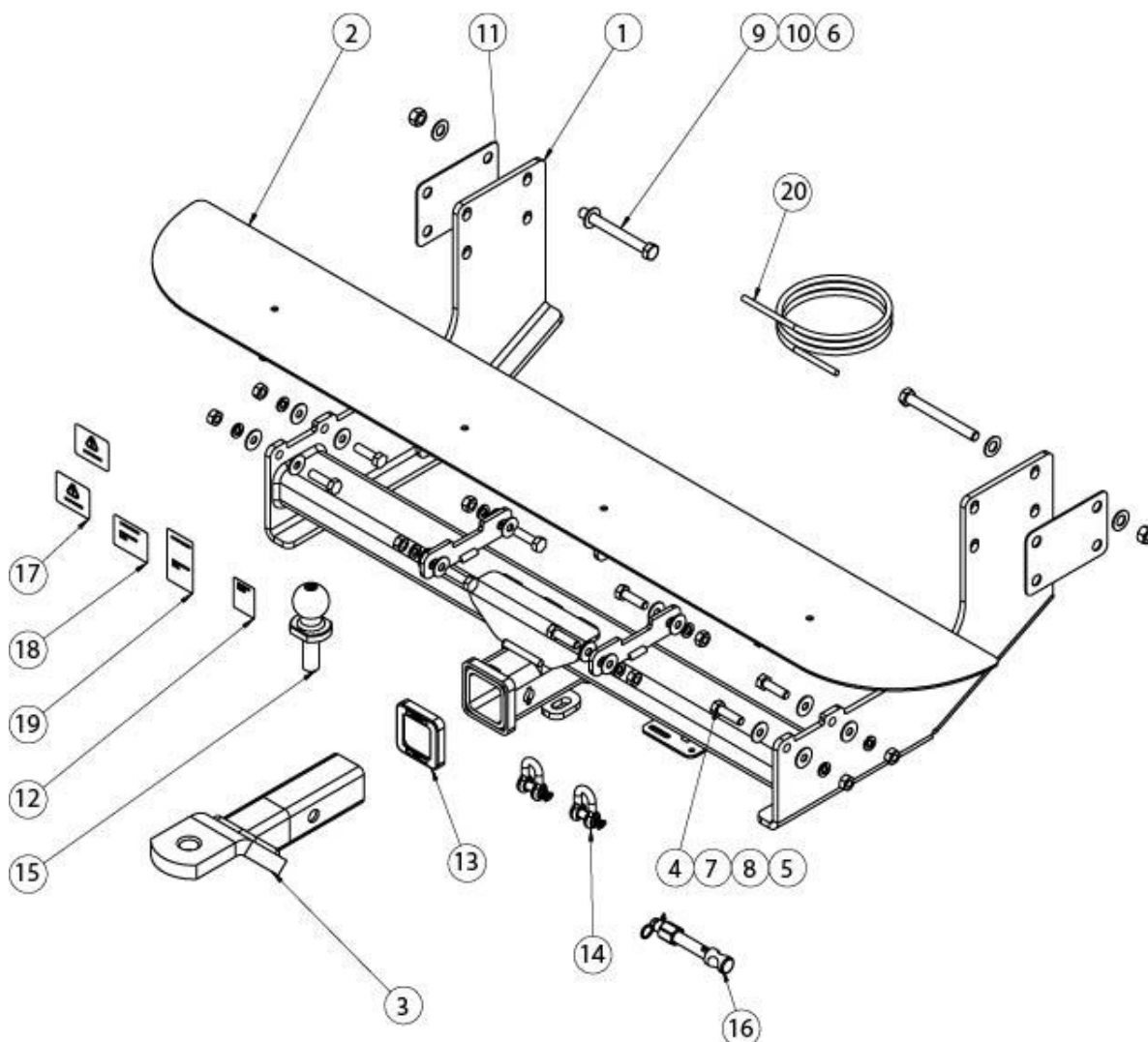

ITEM	DESCRIPTION	QTY
1	MERCEDES SPRINTER ASSEMBLY	1
2	WELDED STEP	1
3	TRAILER BALL MOUNT	1
4	SCREW HEX M10 X 35 X 1.5P	8
5	SPACER, NUT HEX M10 X 1.5P	8
6	NUT HEX M12 X 1.25P	2
7	WASHER PLAIN 3/8 X 1 X 16G	16
8	WASHER SPRING M10 X 3.5 X 2.2	8
9	BOLT HEX M12 X 110 X 1.25P	2
10	WASHER PLAIN 1/2 X 1-1/8 X 16	4

ITEM	DESCRIPTION	QTY
11	SPACER	2
12	HAYMAN REESE LOGO STICKER	1
13	HITCH BOX COLLAR COVER	1
14	"D" SHACKLE 10mm	2
15	TOWBALL 50mm	1
16	SMART PIN GOLD	1
17	CAN MODULE WARNING LABEL	2
18	COMPLIANCE LABEL	1
19	LOAD RATING LABEL	1
20	16 STRANDx0.3mm 7 CORE CABLE	1



# TOWBAR INSTALLATION INSTRUCTIONS

PART NUMBER 03418RW

MERCEDES SPR VAN VS30 RWD AWD

## **i** WIRING ASSEMBLY DIAGRAM

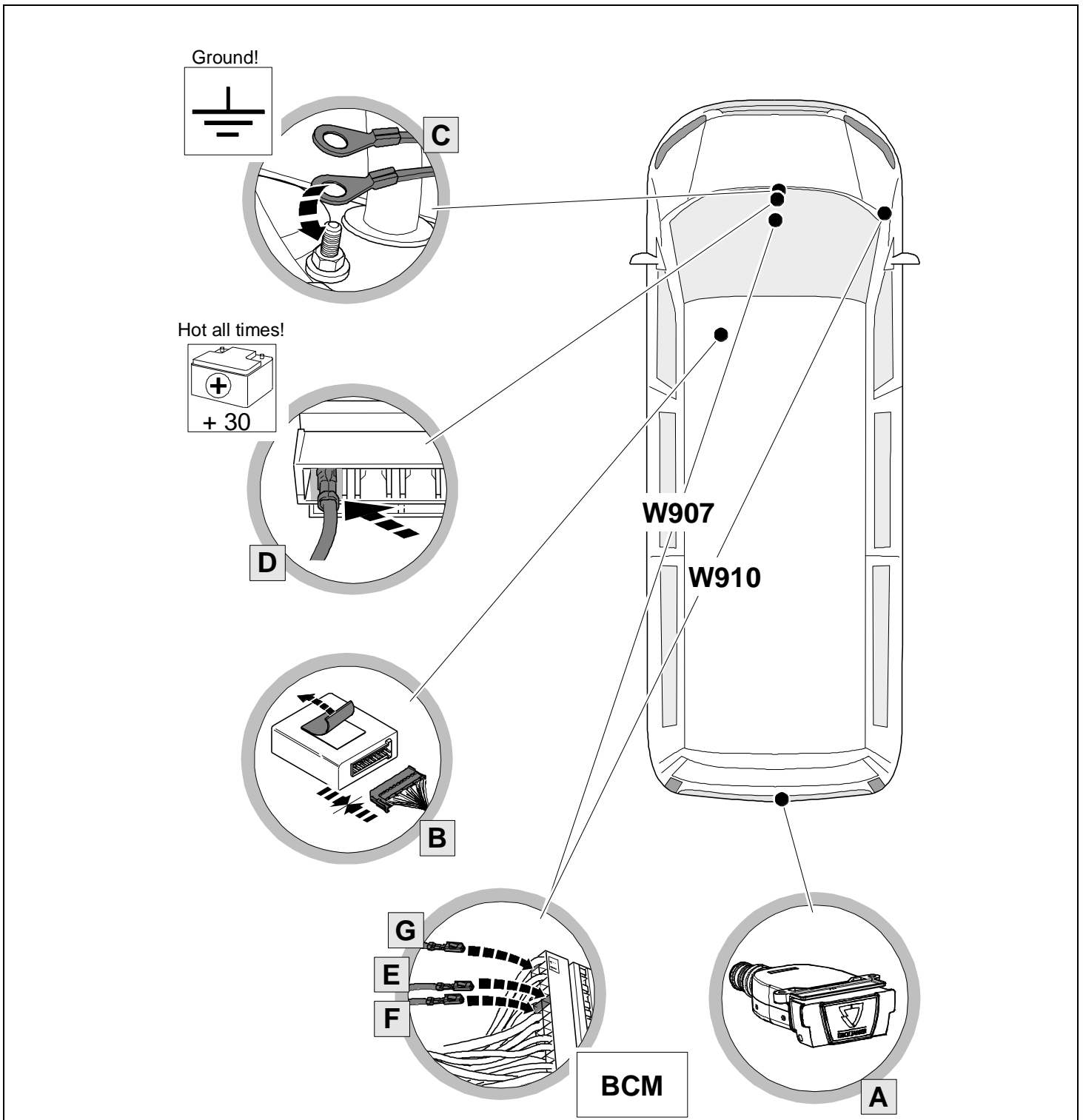



# TOWBAR INSTALLATION INSTRUCTIONS

PART NUMBER 03418RW

MERCEDES SPR VAN VS30 RWD AWD

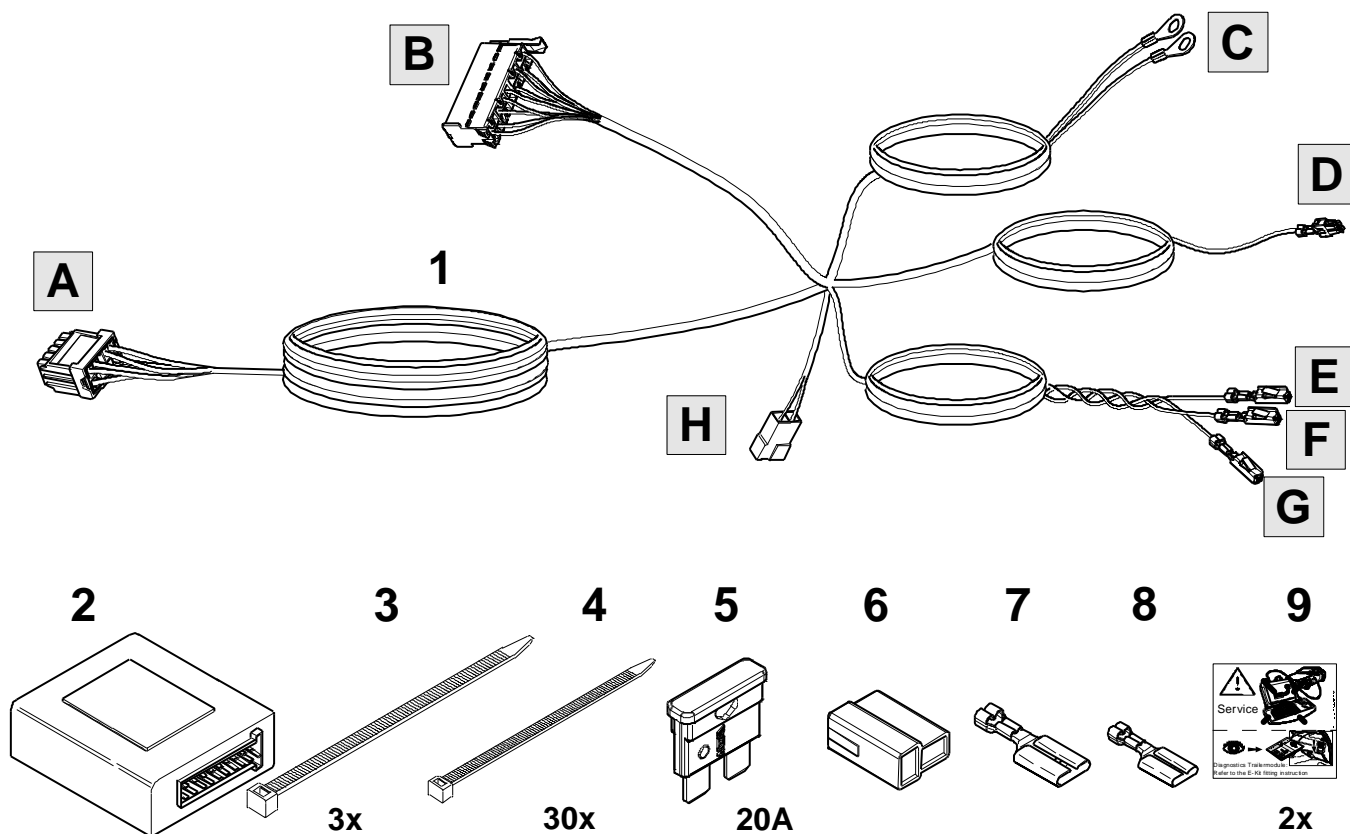

ITEM	DESCRIPTION	QTY
1	Main Harness	1
2	Trailer module (WLE70015)	1
3	Tie Straps 300mm	3
4	Tie Straps 150mm	30
5	20amp fuse	1
6	Brake controller 2-pin housing	1
7	Brake controller plug pin - small	1
8	Brake controller plug pin - large	1
9	Label Diagnostics CAN-Module	2



# TOWBAR INSTALLATION INSTRUCTIONS

PART NUMBER 03418RW

MERCEDES SPR VAN VS30 RWD AWD

1. Position the vehicle to a safe working height.  
Loosen safety bolt.  
Lower the spare wheel for easy access.

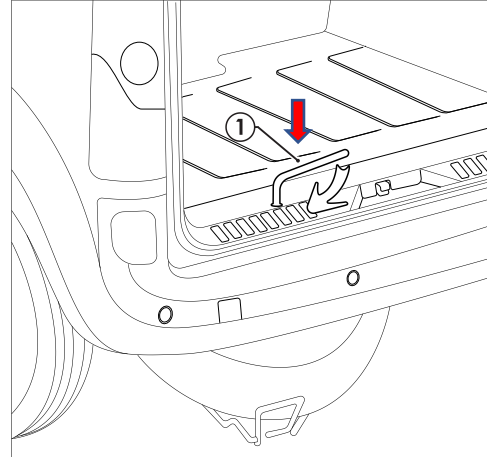

2. Remove the harness cable clip (2x) from the rear step support.  
Disconnect the rear bumper sensor connectors (4x).  
Push to Unclip the bumper tab.

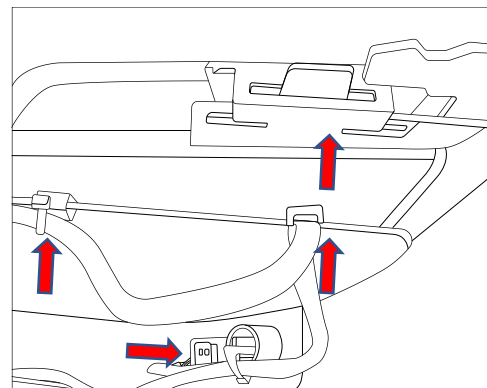

3. Removing torx screws (3x) and scrivets (4x) on the plastic step.  
Pull to remove the plastic step cover.

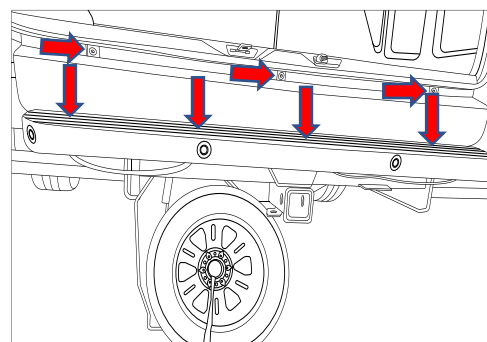



# TOWBAR INSTALLATION INSTRUCTIONS

PART NUMBER 03418RW

MERCEDES SPR VAN VS30 RWD AWD

- 
4. Remove the bolts (3x) and nuts (3x). Retain the bolts and nuts for tow bar fitment.  
Discard the rear step assembly.

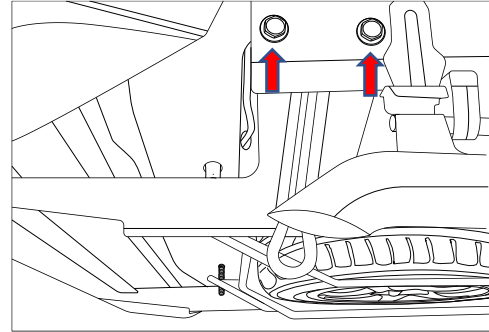

- 
5. Re-fit the existing M12 bolt (3x) in step 8.  
Install an additional M12 bolts (1x) to the mounting holes.

**Note:**

Place the spacer over the bolts as required.  
Repeat step for the other side.

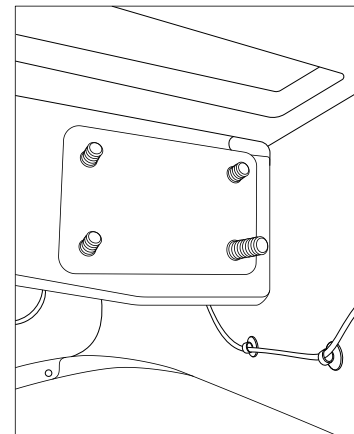

- 
6. Fit the towbar assembly to the vehicle.  
Fit the M12 nuts (4x) and washer (1x) to the bolts.  
Repeat the step for the other side.  
Torques all M12 nuts (8x) to 125Nm.

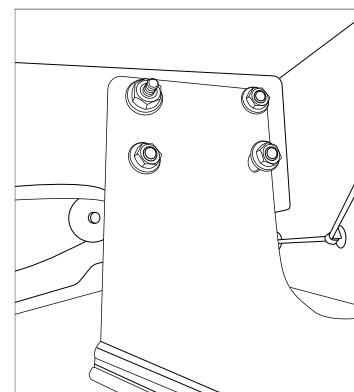



# TOWBAR INSTALLATION INSTRUCTIONS

PART NUMBER 03418RW

MERCEDES SPR VAN VS30 RWD AWD

- 
7. Fit metal step assembly to towbar and fit the M10 bolts (8x), washer (8x), spring washer (4x) and nuts (4x).  
Repeat the step for the other side.  
Torques all M10 nuts (8x) to 44Nm.

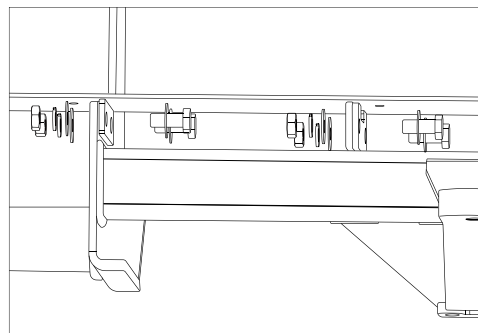

- 
8. Re-fit all removed parts and secure all fasteners, ensuring there are no squeaks or rattles

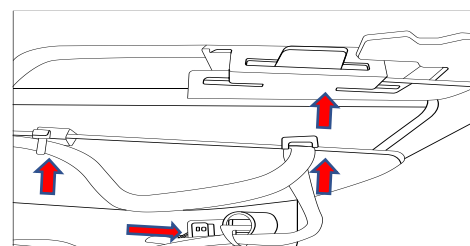
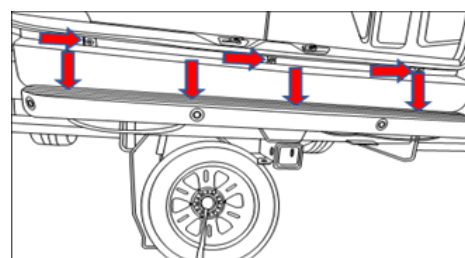



## IMPORTANT

Due to possible vehicle variations, always confirm any noted vehicle colour wires with a multi-meter to ensure the correct function is identified before soldering or scotch locking. For vehicle wires denoted with two colours (example; RED/GREEN) the first colour will always be the main wire colour while the second colour is the thinner trace colour on the wire.

1. Turn off the ignition and remove the key.
2. Keep the keys within 10m of the car if you have Keyless-go to avoid problems.
3. Dismantle the plate from the floor in front of the passenger seat to access the battery cover and disconnect the battery.

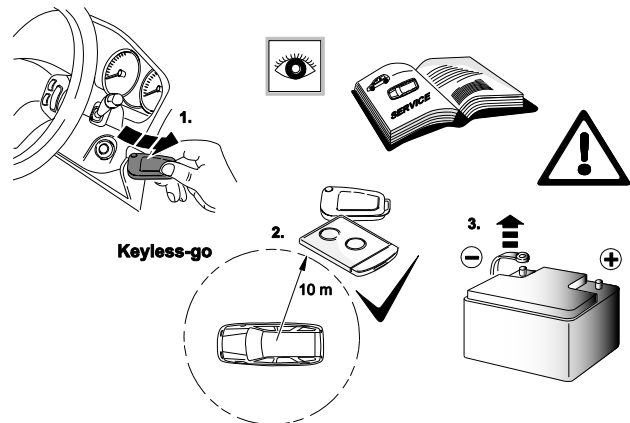

4. Remove all plastic parts under the glove box according the view to access to the fuse box

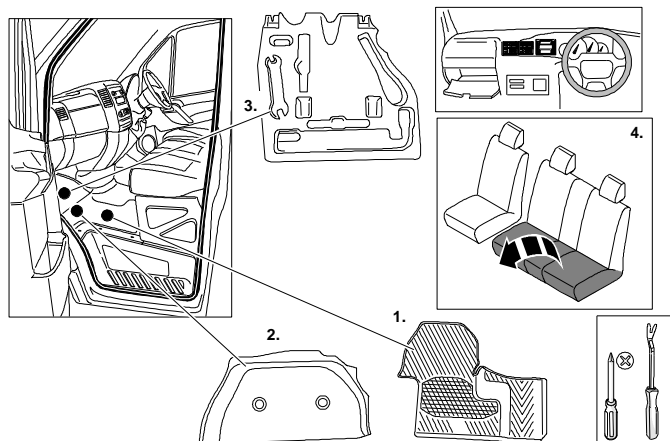



# TOWBAR INSTALLATION INSTRUCTIONS

PART NUMBER 03418RW

MERCEDES SPR VAN VS30 RWD AWD

5. Remove the plastic access panel located under the front passenger seat to reveal the vehicle harness grommet.
6. From underneath the vehicle cut the cable tie.
7. Pull the trailer harness (WLL90015) patch blue connector through the grommet until you reach the branch of the harness.
8. Strap the grommet back to the harness with enclosed tie straps.

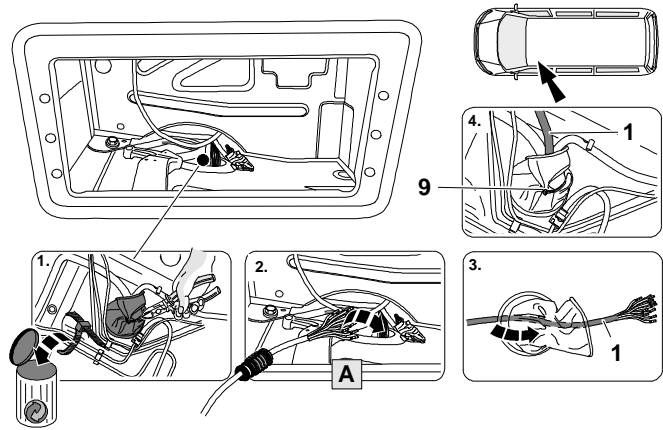

9. Route the trailer harness to the socket plate and fix the trailer harness with enclosed tie straps.

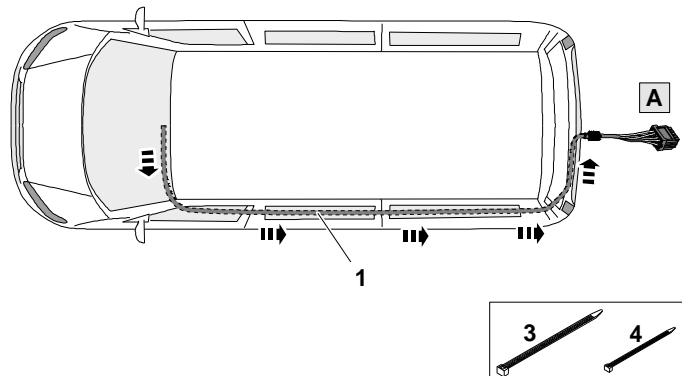

10. Connect tail harness with 8-way connector to outside trailer harness connector (A).

Waterproof the trailer harness 8-way connector (A) and the tail harness 8-way male connector, using silicone or grease.

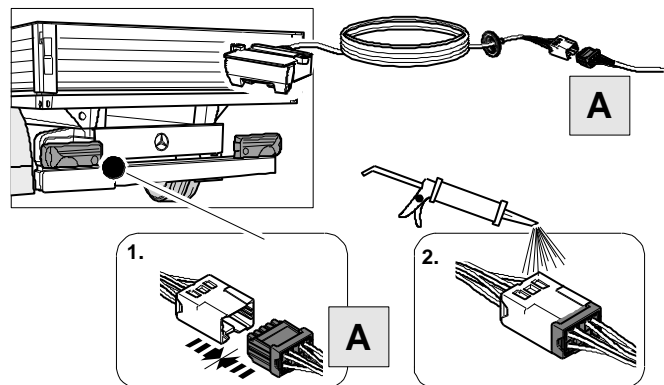

11. Route the trailer harness to the socket plate and fix the trailer harness with enclosed tie straps.

Mount the trailer socket. (AA)

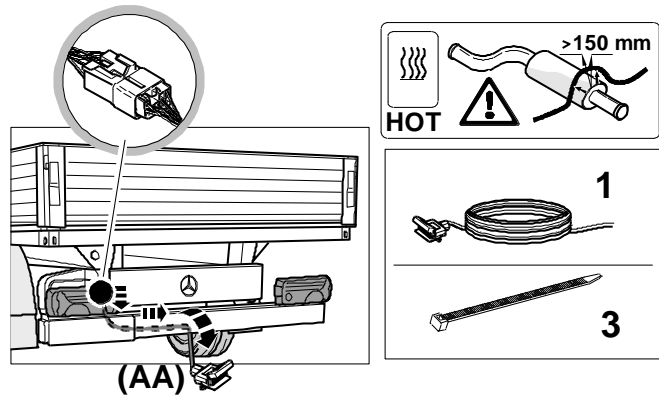

12. Plug the ECU into the trailer patch item (1) location.  
13. Peel the backing of the adhesive tape of the rear of the ECU and mount the ECU in the location shown.

**Ensure the tape has good adhesion.**

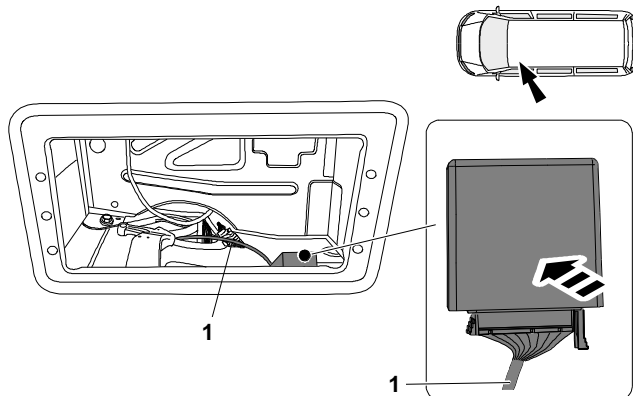

14. Route the trailer patch harness item (1) towards the fuse box.  
15. Connect the trailer patch ring terminals item (1) location (C) to the factory ground stud located left of the centre dash.

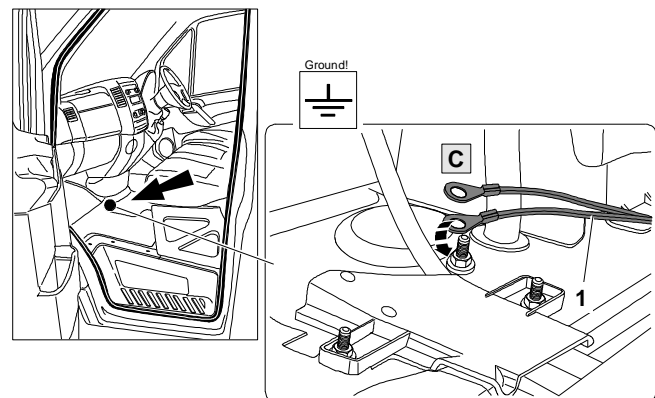



# TOWBAR INSTALLATION INSTRUCTIONS

PART NUMBER 03418RW

MERCEDES SPR VAN VS30 RWD AWD

16. To remove the fuse blocks, lift these tabs each side and lift up and disconnect the block from the main fuse box body.
17. Start with the grey block on the end in order to make the removal of the brown block easier

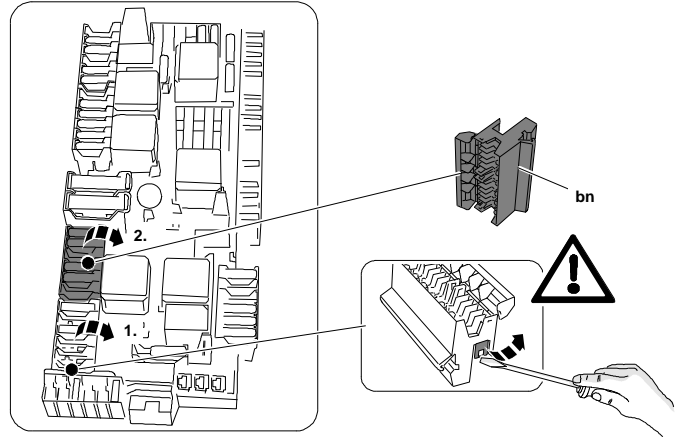

18. Unlock a secondary lock
19. Insert wire D from harness.
20. Ensure proper locking of secondary lock after finishing of the installation

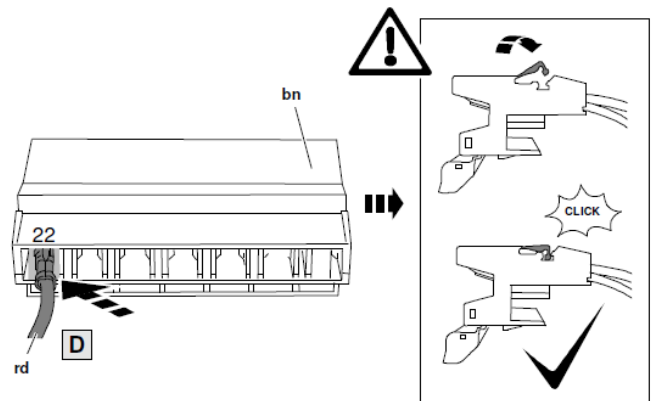

21. Insert fuse 20A (no. 5) from the kit to revive the harness
22. Ensure proper locking of secondary lock after finishing of the installation

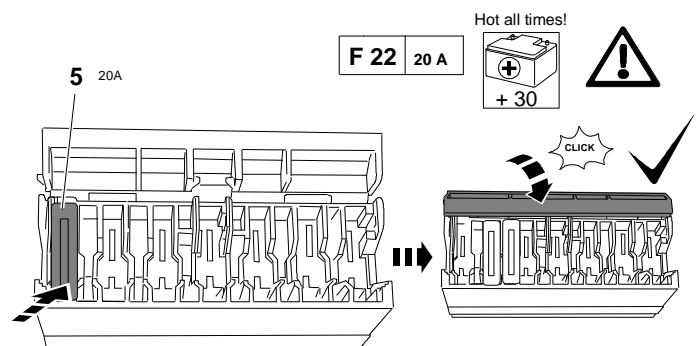



# TOWBAR INSTALLATION INSTRUCTIONS

PART NUMBER 03418RW

MERCEDES SPR VAN VS30 RWD AWD

23. W907: BCM is located in the front on driver side under the side panel
24. Pull out the black connector from the white locking mechanism.
25. If PIN 1 is populated with Blue/White wire un-house and tape back to main harness.
26. Insert the trailer patch terminals item (1) position (E), (F), and (G) into the following pin assignment:

PIN 1 = BK-YE

PIN 8 = BN

PIN 18 = BN-RD

**Note:**

If the vehicle connector pins 8 and 18 are populated, then insert into cavity pin 9 and 19.

PIN 1 = Black/Yellow

PIN 9 = Brown

PIN 19 = Brown/Red

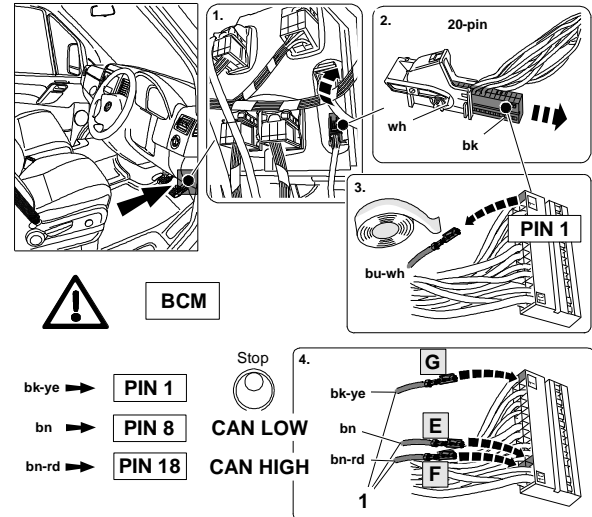

27. W910: BCM is located in the front centre lower part of the dash
28. Pull out the black connector from the white locking mechanism.
29. If PIN 1 is populated with Blue/White wire un-house and tape back to main harness.
30. Insert the trailer patch terminals item (1) position (E), (F), and (G) into the following pin assignment:

PIN 1 = BK-YE

PIN 8 = BN

PIN 18 = BN-RD

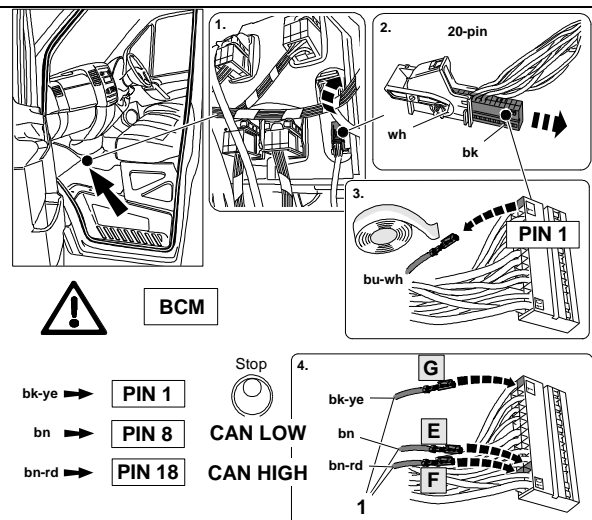

31. Reconnect the battery.
32. Next step is code of vehicle pay attention to the "SmartCode" Instruction page (Appendix A).

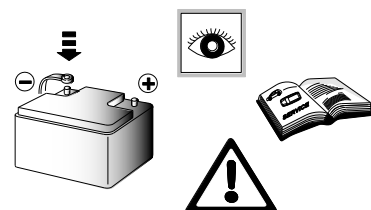



# TOWBAR INSTALLATION INSTRUCTIONS

PART NUMBER 03418RW

MERCEDES SPR VAN VS30 RWD AWD

## 33. Check all light functions.

**Before testing the lights with a tester or trailer connected, the trailer module must be activated by putting your foot on the brake.**

This allows the module to detect if a trailer is connected. Once a trailer is disconnected, another press on the brake will enable the module to detect no trailer is connected.

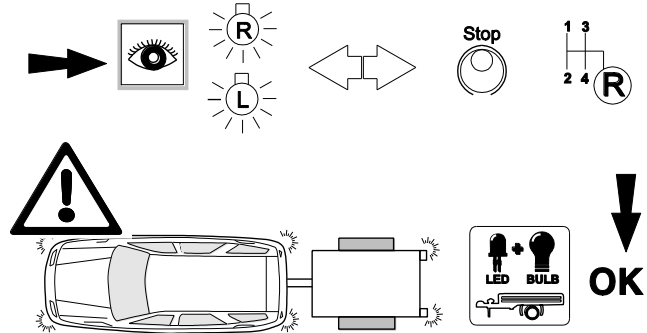

## 34. A trailer bulb out condition is indicated with an increased indicator frequency as well as a display on the dash.

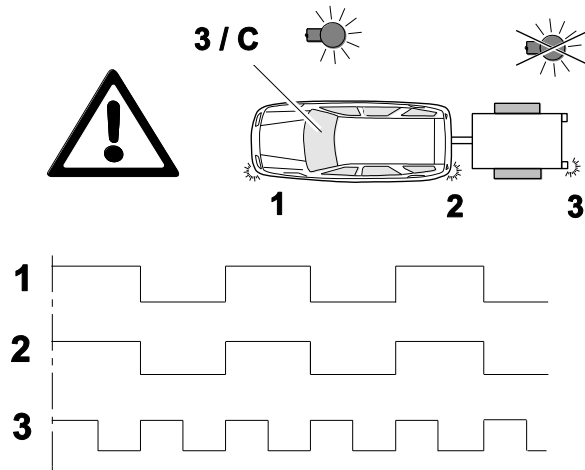

## 35. Information Service.

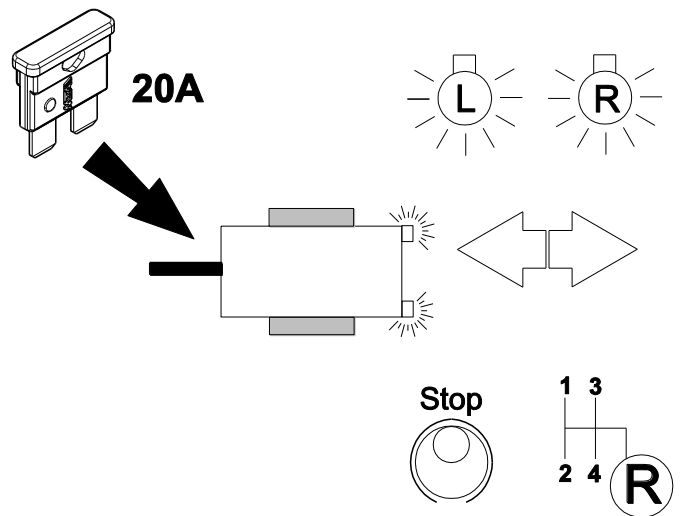



# TOWBAR INSTALLATION INSTRUCTIONS

PART NUMBER 03418RW

MERCEDES SPR VAN VS30 RWD AWD

**BRAKE  
CONTROLLER  
PREPARED**

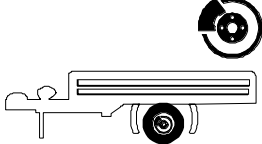

## Trailer Brake Preparation

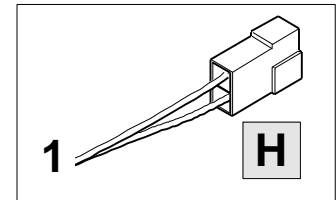

1.

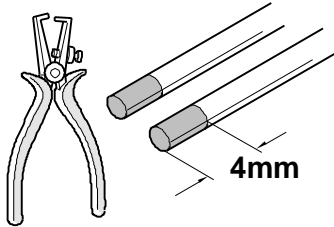

2.

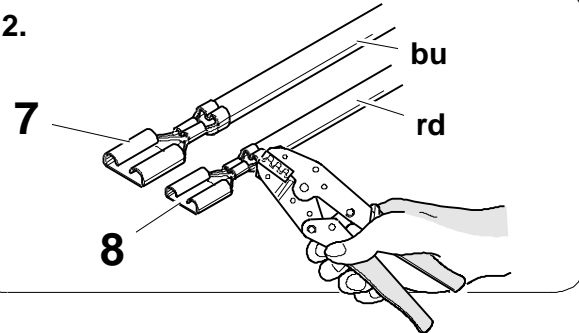

3.

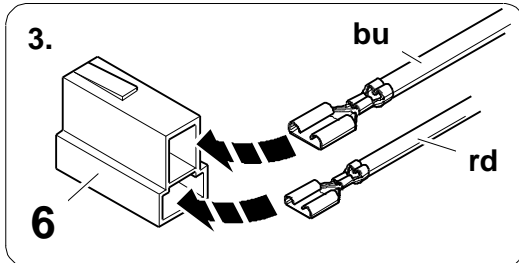

4.

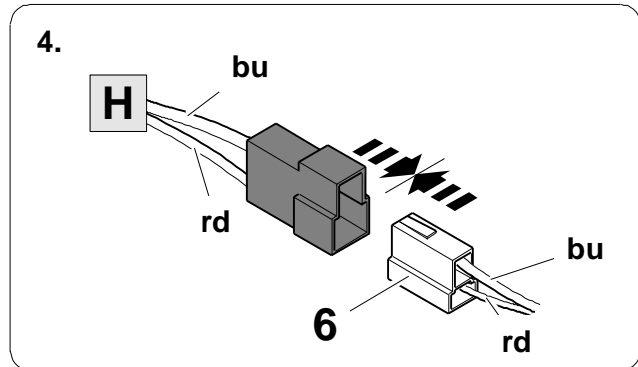

6

7

8

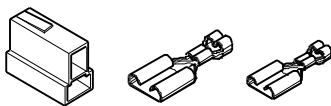



# CUSTOMER INFORMATION

PLACE THESE INSTRUCTIONS IN THE  
VEHICLE'S GLOVEBOX AFTER INSTALLATION

**THANK YOU FOR PURCHASING HAYMAN REESE.  
WITH CORRECT MAINTENANCE AND CARE THIS PRODUCT WILL PROVIDE A  
LIFETIME OF TROUBLE-FREE OPERATION.**

## **i** TOWBAR MAINTENANCE AND CARE:

1. Hayman Reese recommend that the towbar LUG or TBM (tow ball Mount) Pull Pin and R-clip are removed and stored when not in use. Removal of LUG or TBM (tow ball mount) is advisable when not in use to assist with any of the following.
  - Ensure rear number plate is not obscured.
  - Allow maximum available departure angle and prevent any potential interference.
  - Prevent possible interference with vehicles reverse sensors or camera detecting a tow ball mount as an obstruction during reversing.
  - Removes towball mount as an obstruction for when moving around the rear of the vehicle.
2. Hayman Reese recommends routine inspection of your towbar to ensure trouble free towing.
  - Bolt security and tension should be regularly inspected and checked for correct tension. Replace any worn or defective parts with suitable grade & class fasteners. Inspection should be requested to coincide with vehicle major services.
3. It is the owner's responsibility to ensure towing and down ball weight capacities of the towing vehicle are not exceeded.
  - Towing and down ball weights allowable may differ according to model variations. Please refer to owner's manual or vehicle dealer to confirm exact rating for your vehicle model variant.
  - It is not uncommon for the vehicle tow rating to differ from the towbar rating. When this occurs, the lesser rating must be adhered to.
  - For vehicles fitted with enhanced vehicle functions that may be altered/changed when towing i.e Trailer sway mitigation, blind spot detection, adaptive cruise control etc. Please consult owner's manual to understand changes enabled when towing and after towing.

## **WARRANTY INFORMATION:**

Hayman Reese Towbars are covered by a Lifetime Warranty.

Our goods come with guarantees that cannot be excluded under the Australian Consumer Law. You are entitled to a replacement or refund for a major failure and for compensation for any other reasonably foreseeable loss or damage. You are also entitled to have the goods repaired or replaced if the goods fail to be of acceptable quality and the failure does not amount to a major failure.

For further details please visit [www.haymanreese.com.au/warranty](http://www.haymanreese.com.au/warranty) or contact customer service on 1800 812 017 or [info@haymanreese.com.au](mailto:info@haymanreese.com.au).





# CUSTOMER INFORMATION

PLACE THESE INSTRUCTIONS IN THE VEHICLE'S GLOVEBOX AFTER INSTALLATION

## HAYMAN REESE SMART PIN

Your Hayman Reese towbar is equipped with Smart Pin technology to help reduce towbar tongue rattle in most driving conditions. Please ensure below instructions are understood and routine maintenance is carried out to ensure best towing experience.

**i** Regularly inspect for wear and check the tightness of the Smart Pin Nut. Follow instructions below to re-tighten the nut as necessary when movement and noise in the tow ball mount is noted.

- Before towing, ensure R-Clip is properly installed and Smart pin nut is installed and tensioned. Replacement parts are available from your Hayman Reese Distributor.

## TOWBALL MOUNT REMOVAL/INSTALLATION

### STEP 1

Insert Trailer Ball Mount (TBM) (a) into towbar hitchbox (b), aligning hole in TBM shank (c) with hole in hitchbox (d) (Fig. 1)

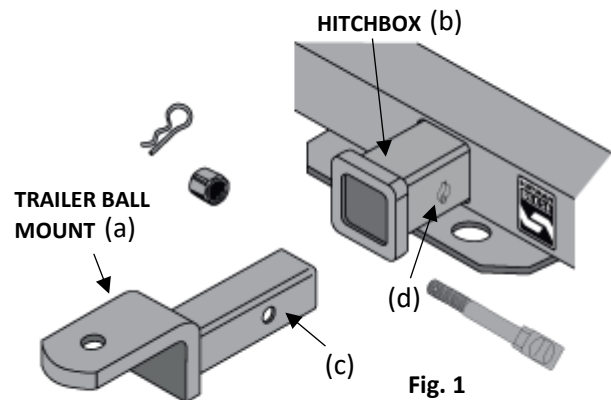

### STEP 2

Insert Smart Pin (e) through hole in hitchbox and hole in TBM shank (g); ensure the locators are inserted into the notches in the hitchbox (Fig. 2)

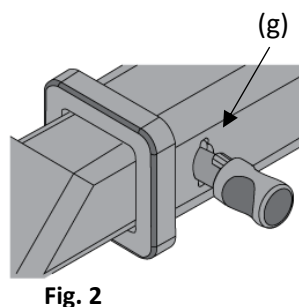

### STEP 3

Screw Smart Pin Nut (f) onto Smart Pin (g); tighten Smart Pin Nut until finger tight, ensuring TBM is restrained from up and down movement.

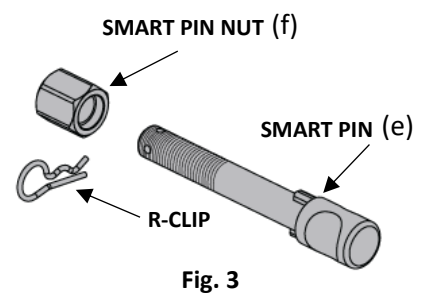

### STEP 4

Tighten Smart Pin Nut by turning nut a further 1/8th of a turn in the clockwise direction using a 24mm spanner (Fig. 4).

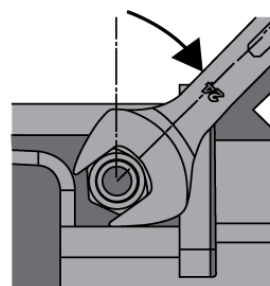

### STEP 5

Install Smart Pin R-Clip through the hole that provides best clearance or easiest access. (Fig. 5)

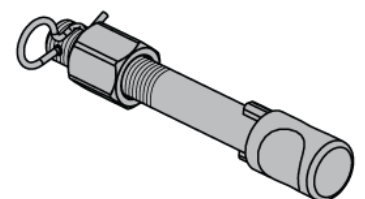

# Appendix



**WARNING:** This vehicle requires a system setting to ensure the trailer wiring and control module are correctly recognised. This process (referred to as 'coding') must be carried out to enable correct vehicle functionality when trailer is connected. Towing features enabled by correct control module and coding support OE functionality as set by OE manufacturer. Please read the vehicles owner's manual for proper operation and understanding.

Coding can be carried out using the Hayman Reese SmartCODE (HRSC) using the following steps. Note, if HRSC is unavailable, vehicle coding can be carried out by OE manufacturer as needed.

Before you start:

- **Ensure the HRSC software is up to date using the HAYMAN REESE SMARTCODE PC APP.**
  - **Ensure the vehicle battery is fully charged**
  - **Use of a battery support unit (BSU) is advised during the coding process.**
  - **Ensure towbar, wiring loom and ECU are correctly installed as per Hayman Reese fitting instructions.**
1. Locate the OBD2 port under the drivers footwell on the right-hand side and plug in the HRSC.
  2. Close all doors and turn the ignition on
  3. Follow the directions on the screen of the HRSC
  4. Once the vehicle has been coded successfully proceed to the "clear codes" tab
  5. Remove disconnect HRSC from OBD2 port.
  6. Check the dash to make sure there are no warning faults.
  7. Check the operation of trailer lights and ensure the Reverse Park Assist (RPA) is disabled and 'trailer on' icon is active where available.

For technical support and further information on Hayman Reese SmartCODE tool and coding process contact your nearest Hayman Reese stockist.

Australia: 1800 812 017

New Zealand: 0800 237 886