



# TOWBAR INSTALLATION INSTRUCTIONS

PART NUMBER 03424RW

LANDROVER RANGEROVER EVOQUE L551 CL4



## PRODUCT DETAILS:

Part Number:	03424RW	Maximum Towing Braked:	2000	kg
ECU Number:	WLE70010	Maximum Towing Unbraked:	750	kg
Tail Harness Length Required:	1200mm	Maximum Static Ball Load:	150	kg
TBM/Lug Part Number:	21331			
Wiring Part Number:	WLL90010			

## FITTING DETAILS:

Towbar Installation Time:	120 Mins.	Hayman Reese SmartCODE Solution Required:	NO
Wiring Installation Time:	30 Mins.	RPA Disable/Other:	YES
Total Installation Time:	150 Mins.		
Bumper Cut Required:	Yes	Note:	

- RPA disable via infotainment.



# TOWBAR INSTALLATION INSTRUCTIONS

PART NUMBER 03424RW

LANDROVER RANGEROVER EVOQUE L551 CL4

ENSURE THAT INSTRUCTIONS ARE UNDERSTOOD PRIOR TO FITMENT.

## **i** BEFORE YOU START:

Hayman Reese recommends that instructions are read completely prior to fitment. Check all hardware items have been included refer to assembly diagram. Please ensure this towbar is only fitted to vehicle models as per Hayman Reese application guide ([www.haymanreese.com.au](http://www.haymanreese.com.au)).

### Bumper Cuts



Vehicle and bumper variations can and do occur during vehicle manufacture after initial towbar design. Fitment of towbar to vehicle and accuracy of bumper cut must be assessed prior to any bumper modifications made. Incorrect bumper cuts are not covered under Hayman Reese warranty.

**NOTE: Bumper cuts need to be approached with care, refer to notes below.**

- Bumper centreline – where the centreline of the bumper needs to be determined, the installer must assess centre point by measurement of bumper width or determining two symmetrical reference points to give centreline.
- Bumper edge – To assist with accurate bumper cut measurement, reference to the start of the bumper edge is now being commonly used.
  - Measure from bottom edge along bumper and around corner to the 70 mm point (Figure 1).
  - Do not measure from visible bumper front of corner, upwards (Figure 2).

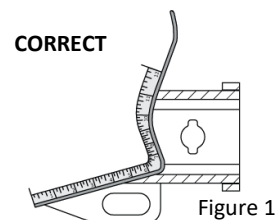

Figure 1

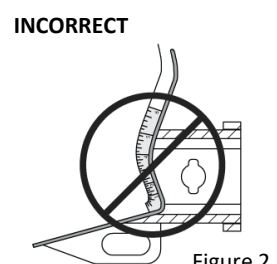

Figure 2

### Drilling

- For any required drilling during installation, ensure that the area is clear of fuel, electrical & other components that may be damaged.
- All holes drilled into the body panels shall have all burrs & swarf removed then coated with a suitable rust preventative paint.

### Bolts/Fasteners

- Ensure that all hardware is fastened to correct torque as specified in this fitting instruction.
- All fasteners supplied with this product are used to achieve a specified clamp loading. If replacement is required ensure that fasteners of the same grade and class are used.



**NOTE: Achieving correct torque is critical to proper installation and responsibility of the installer. Towbar failures attributed to tension issues from over tightening or under tightening are not covered by Hayman Reese warranty.**

### Product Labels

- a. Towbar load rating sticker provided with this product shall be conspicuously located on inside rear end of the driver's door.
- b. Powertrain Control Module (PCM)/Body Control Module (BCM) upgrade warning label will be provided in towbar kit for vehicles as required. Affix warning label in door and owner's handbook.

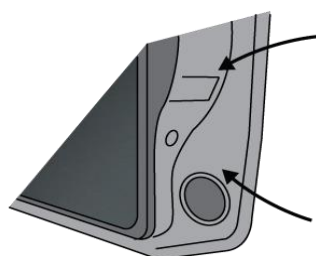

Place **Load Rating sticker** inside driver's door here

Place **Vehicle PCM/ BCM upgrade warning label** in door AND on front cover of owner's service handbook

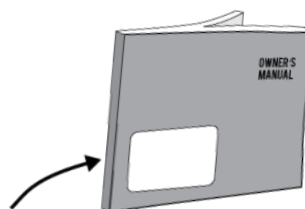

## WARNING:

**Do not, drill, cut, weld or otherwise modify the towbar.**

**FOR TOWING PURPOSES ONLY - This towbar is designed and tested by Hayman Reese to adhere to ADR 62/02 which provides only for the expected load demands of towing.**



# TOWBAR INSTALLATION INSTRUCTIONS

PART NUMBER 03424RW

LANDROVER RANGEROVER EVOQUE L551 CL4

## **i** TOWBAR ASSEMBLY DIAGRAM

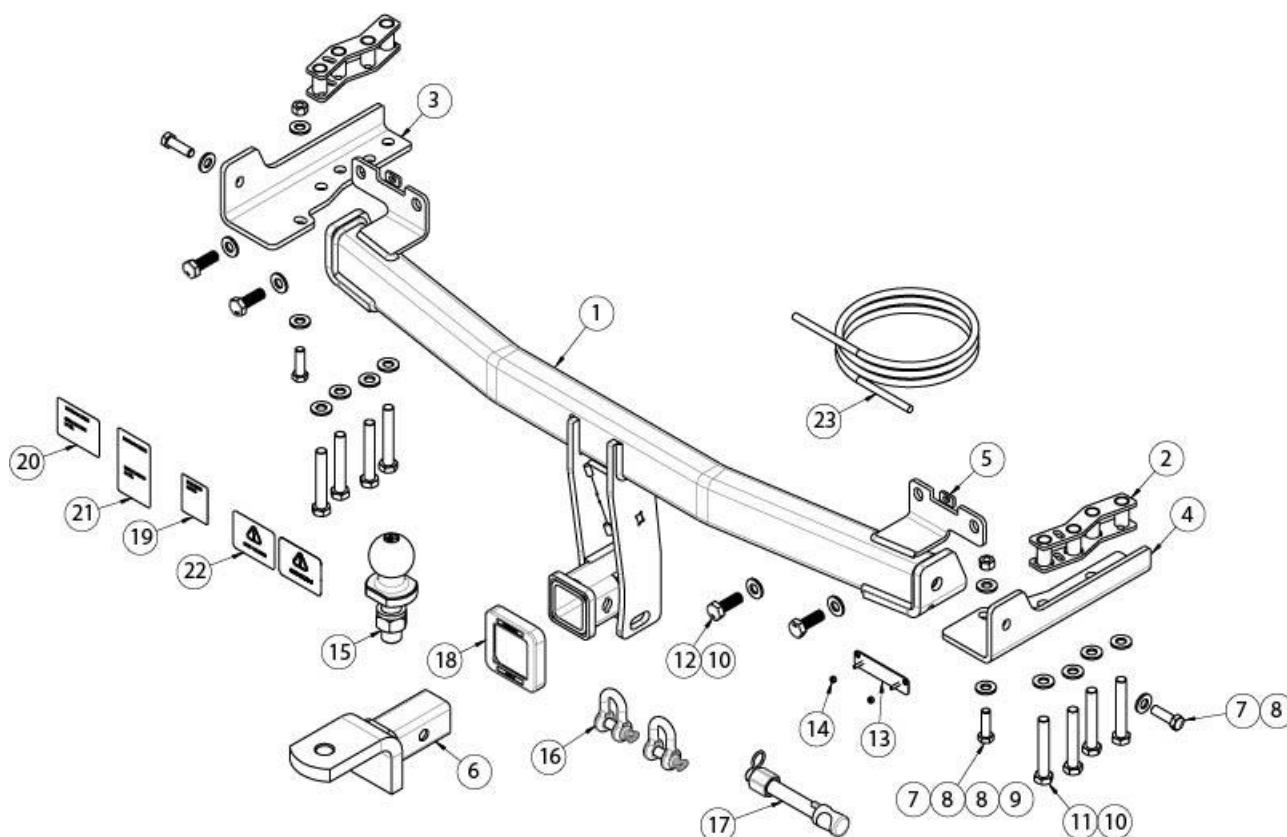

ITEM	DESCRIPTION	QTY
1	EVOQUE CROSSTUBE ASSY	1
2	CRUSH PLATE ASSEMBLY	2
3	CHASSIS RAIL PLATE, LH	1
4	CHASSIS RAIL PLATE, RH	1
5	BUMPER BRACKET SPACER	2
6	TRAILER BALL MOUNT	1
7	SET SCREW HEX HD M12x40x1.75P	4
8	WASHER PLAIN 1/2"	6
9	NUT HEX HD M12x1.75P	2
10	WASHER PLAIN M14x28x3mm	12
11	BOLT HEX HD M14x90x2.0P	8
12	SET SCREW HEX HD M14x40x2.0P	4

ITEM	DESCRIPTION	QTY
13	PLUG BRACKET	1
14	NUT NYLOC HEX HD M4x0.7P	2
15	TOWBALL 50mm	1
16	"D" SHACKLE 10mm	2
17	SMART PIN GOLD	1
18	HITCH BOX COLLAR COVER	1
19	HAYMAN REESE LOGO STICKER	1
20	COMPLIANCE LABEL	1
21	LOAD RATING LABEL	1
22	CAN MODULE WARNING LABEL	2
23	WIRING LOOM	1



# TOWBAR INSTALLATION INSTRUCTIONS

PART NUMBER 03424RW

LANDROVER RANGEROVER EVOQUE L551 CL4

## **i** WIRING ASSEMBLY DIAGRAM

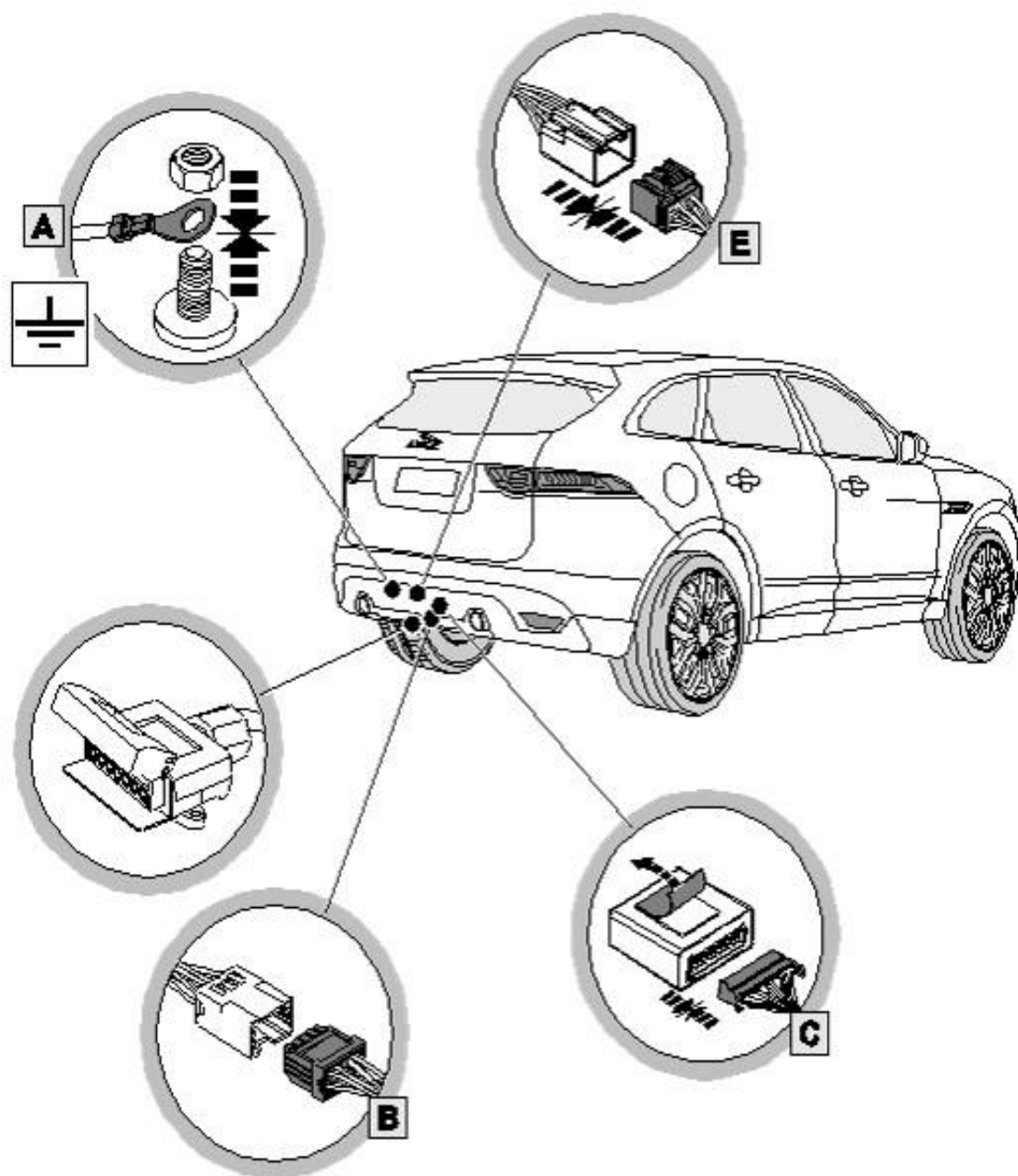



# TOWBAR INSTALLATION INSTRUCTIONS

PART NUMBER 03424RW

LANDROVER RANGEROVER EVOQUE L551 CL4

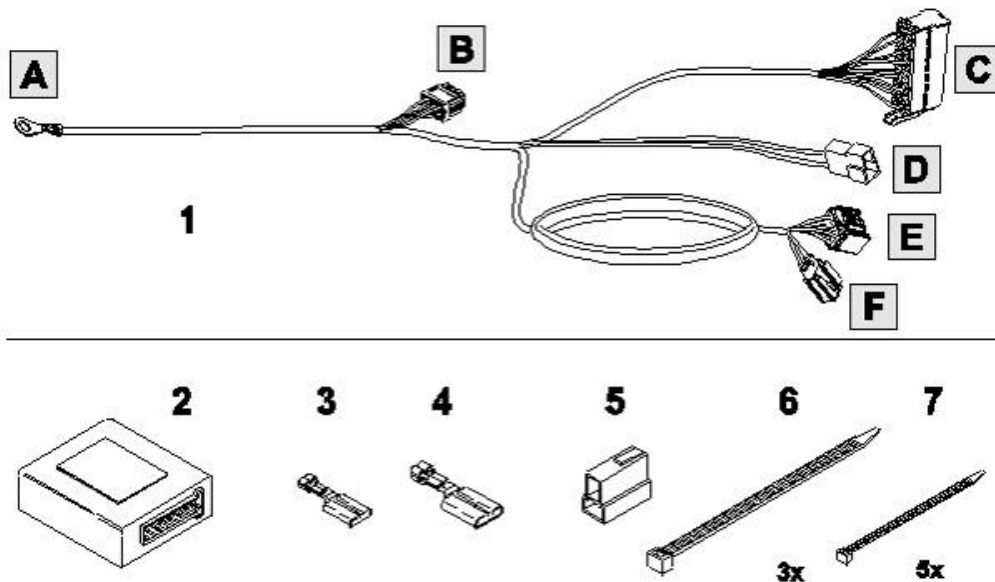

ITEM	DESCRIPTION	QTY
1	Trailer patch harness	1
2	Trailer module → WLE70010	1
3	Brake control plug pin - small	1
4	Brake control plug pin - large	1
5	Brake controller 2-pin housing	1
6	300mm Cable tie	3
7	150mm Cable tie	5

## TOOLS

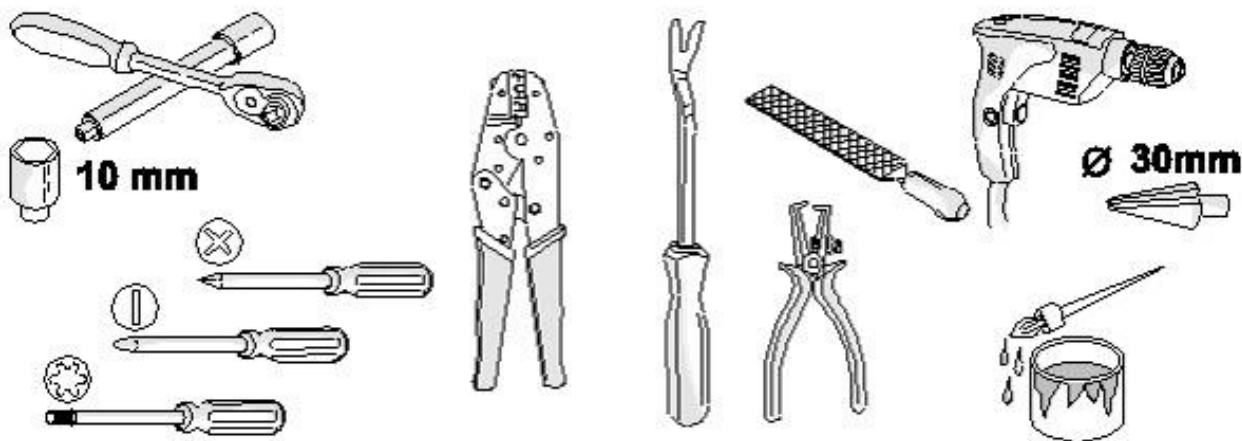



# TOWBAR INSTALLATION INSTRUCTIONS

PART NUMBER 03424RW

LANDROVER RANGEROVER EVOQUE L551 CL4

1. In wheel arch, remove 3 x screws.

Repeat for other side.

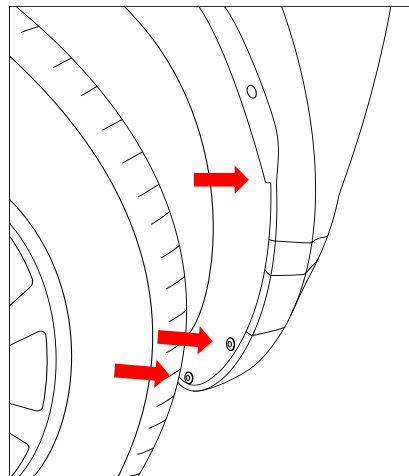

2. Peel back wheel arch trim and remove the exposed 2 x screws

Repeat for other side

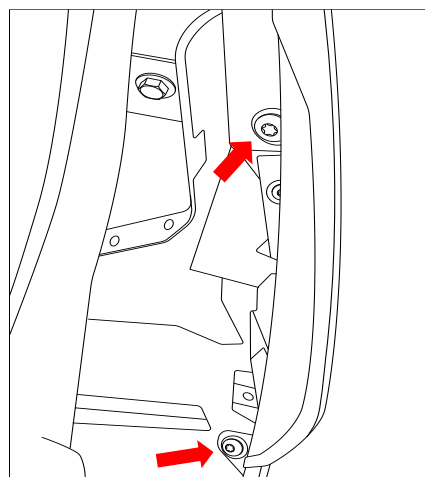

3. On the drivers side in the wheel arch behind the wheel arch trim, disconnect the bumper wiring harness plug.

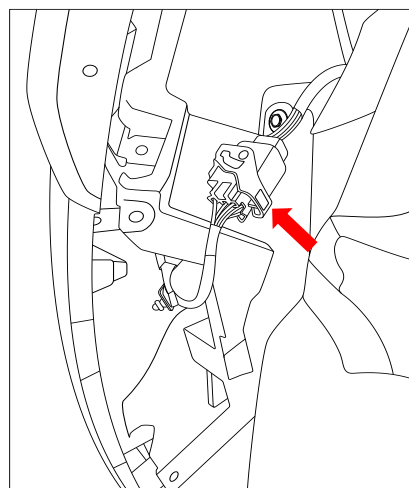



# TOWBAR INSTALLATION INSTRUCTIONS

PART NUMBER 03424RW

LANDROVER RANGEROVER EVOQUE L551 CL4

4. Open tailgate and remove taillight cover.

Repeat for other side

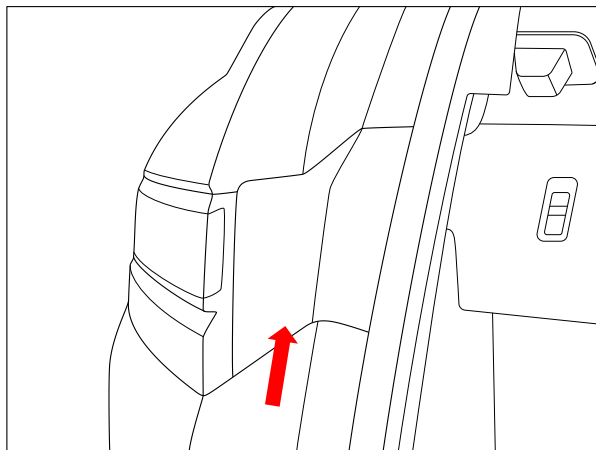

5. Remove the exposed bumper screw.
6. Remove plastic bumper cap.

Repeat for other side.

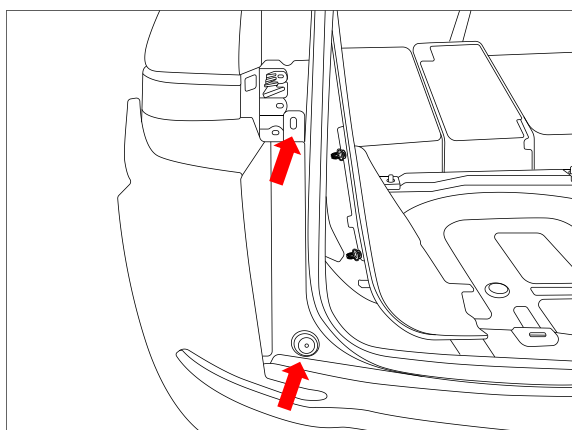

7. Along the underside of the bumper remove 8 x fasteners.

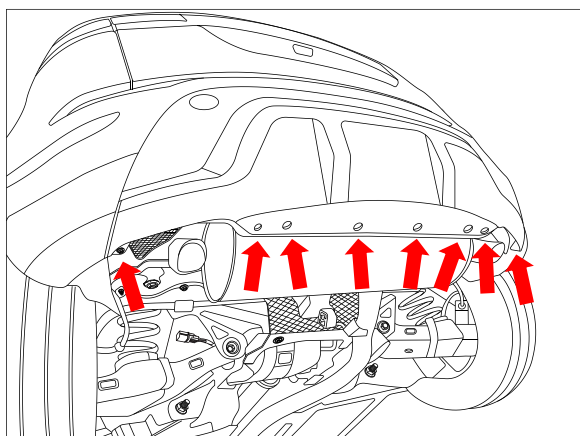



# TOWBAR INSTALLATION INSTRUCTIONS

PART NUMBER 03424RW

LANDROVER RANGEROVER EVOQUE L551 CL4

8. Peel bumper away from the sides and remove from vehicle.

Extreme rearward force may be required to unclip the centre section of the bumper from the rear rail (Image depicts the clip positions with the bumper removed).

Ensure that harness is disconnected (step 3)

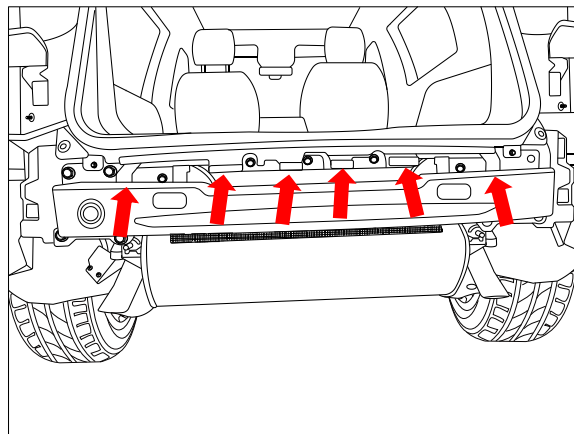

9. Loosen the upper 1 x bolt on the bumper bracket support plate. Remove the 1 x nut from the lower stud.

Repeat for the other side.

10. Remove the impact beam secured with 4 x bolts per side.

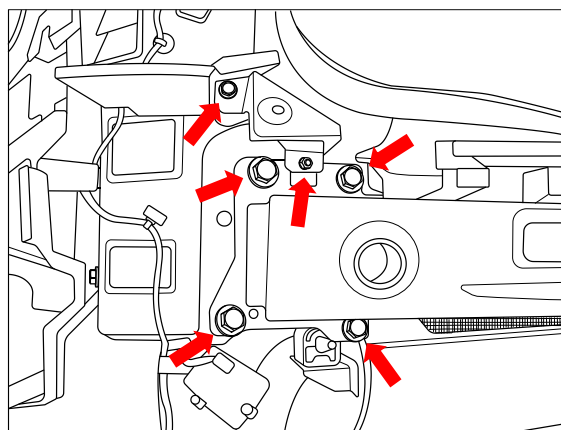

11. Remove the heat shield secured with 1 x bolt per side.

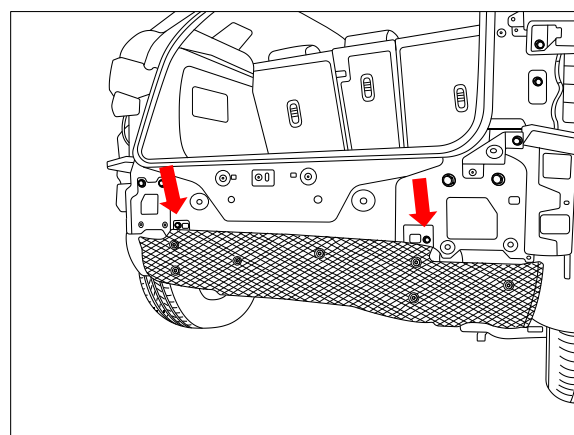





# TOWBAR INSTALLATION INSTRUCTIONS

PART NUMBER 03424RW

LANDROVER RANGEROVER EVOQUE L551 CL4

12. From under the chassis rail, remove and discard the towhook secured with 2 x bolts.

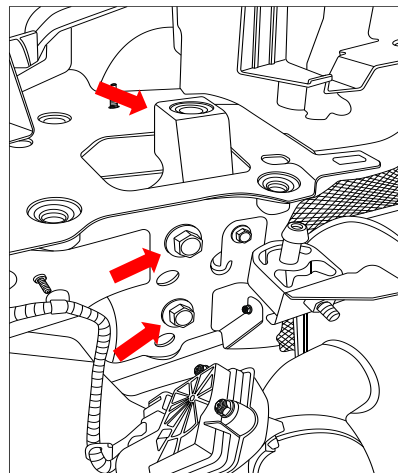

13. Insert the side arm along with the crush plate assembly (see item 2 on page 3) into the chassis rail and loosely secure with 4 x M14 bolts complete with 1 x washer per bolt.

Repeat for other side.

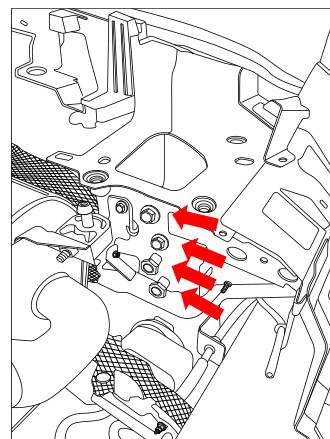

14. Position the crosstube onto the side arms and loosely secure each end to the back panel with 2 x M14 bolts complete with 1x washer per bolt.

15. Secure the side arm to the crosstube captive nut with 1x M12 bolt complete with 1x washer and to the bottom plate with 1 x M12 bolt complete with 2x washers and 1 x nut.

16. Reattach the bumper bracket along with the supplied bumper bracket spacer in position with the removed hardware.

Repeat step 14 to 16 for the other side.

17. Tighten all fasteners to the following torque:

**M12 x 1.75 Gr10.9 : 109Nm**

**M14 x 2 Gr 8.8 : 124Nm**

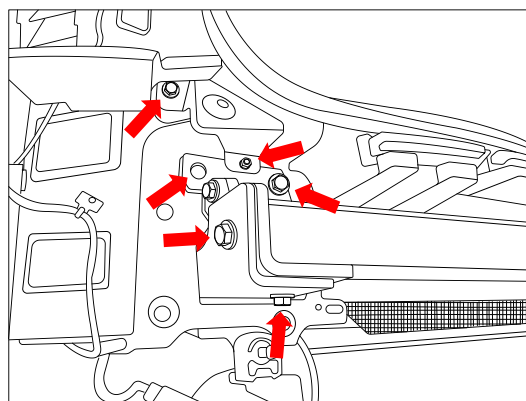



# TOWBAR INSTALLATION INSTRUCTIONS

PART NUMBER 03424RW

LANDROVER RANGEROVER EVOQUE L551 CL4

## 18. For bumper cut.

Determine the centre of the bumper, measure, and mark off 200mm long (from bottom edge of bumper following the bumper profile) and 90mm wide.

Proceed to cutout the bumper following the bumper profile.

**Ensure to not cut through or damage any cables on the inside of the bumper.**

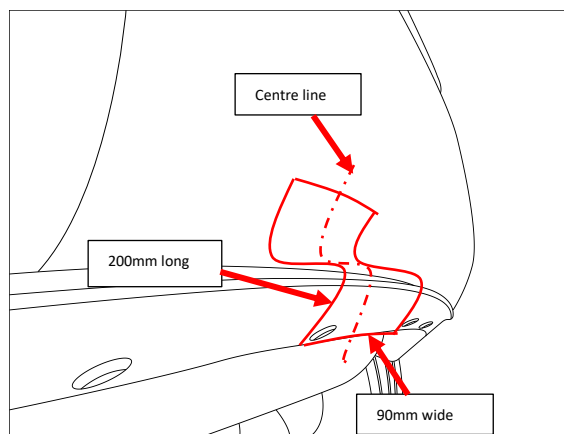

## 19. For plug bracket.

At an appropriate position on the bumper, mark out and drill 2x  $\varnothing 5\text{mm}$  holes 69mm apart on bumper skin to support plug bracket.

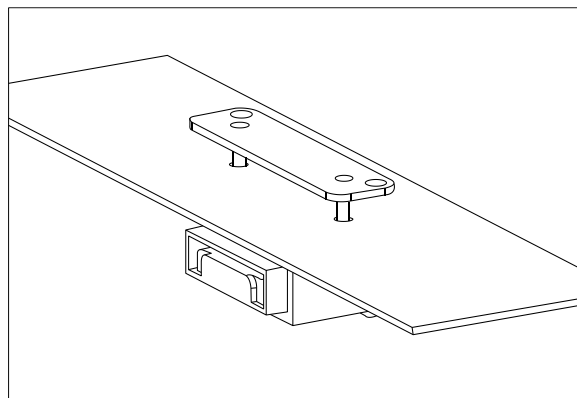



# TOWBAR INSTALLATION INSTRUCTIONS

PART NUMBER 03424RW

LANDROVER RANGEROVER EVOQUE L551 CL4

## IMPORTANT

Due to possible vehicle variations, always confirm any noted vehicle colour wires with a multi-meter to ensure the correct function is identified before soldering or scotch locking. For vehicle wires denoted with two colours (example; RED/GREEN) the first colour will always be the main wire colour while the second colour is the thinner trace colour on the wire.

20. Open the rear tailgate and remove the keys from the vehicle.
21. Remove the rear sunshade.
22. Remove the rear luggage compartment floor trim.

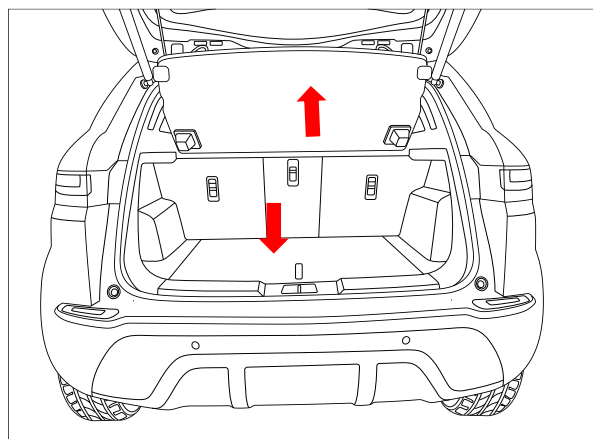

23. Remove the foam tool box and spare wheel.
24. Remove the rear luggage compartment sill trim.

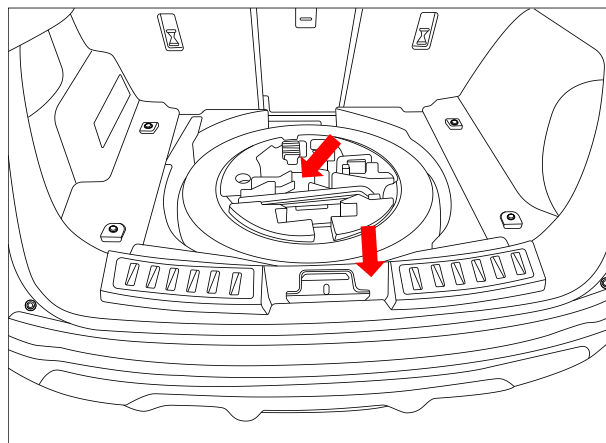



# TOWBAR INSTALLATION INSTRUCTIONS

PART NUMBER 03424RW

LANDROVER RANGEROVER EVOQUE L551 CL4

25. Remove the LHS 2x cargo hooks.
26. Remove the 2x plastic scrivenets.

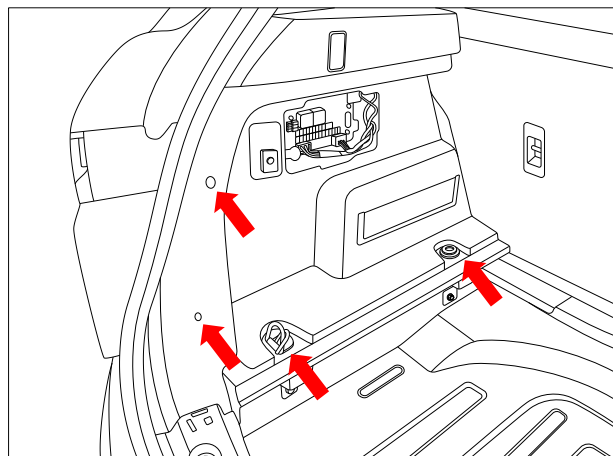

27. Dislodge the lower luggage compartment trim.

**Allow enough space to access work area.  
If more space is required disconnect Aux 2-way  
connector.**

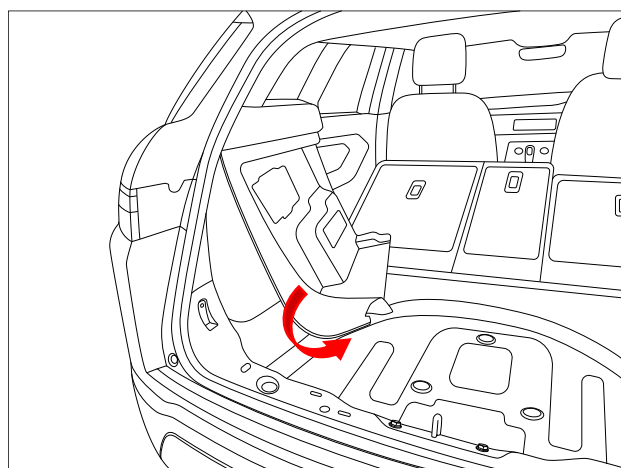

28. Locate the LHS blanking grommet and remove.
29. Using a step drill enlarge the hole to Ø30mm.

**Remove all sharp edges and spray rust inhibitor.**

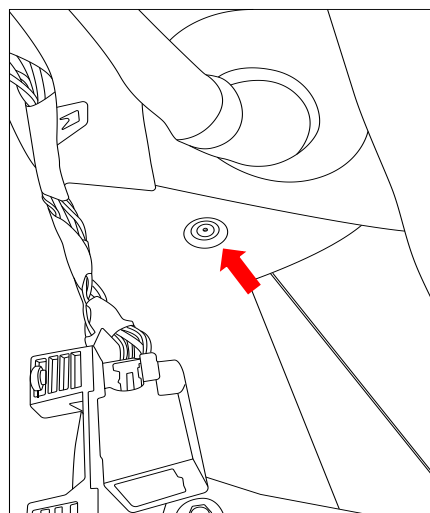



# TOWBAR INSTALLATION INSTRUCTIONS

PART NUMBER 03424RW

LANDROVER RANGEROVER EVOQUE L551 CL4

30. From outside the vehicle route and secure the tail harness (1200mm) to the towbar allowing enough length to later secure to plug bracket.
31. Slide the grommet to desired location and secure with cable tie.
32. Secure the grommet in the previously drilled hole, **ensure the grommet is seated properly.**
33. Plug the tail blue connector to the trailer patch (1) to mating connector (B).

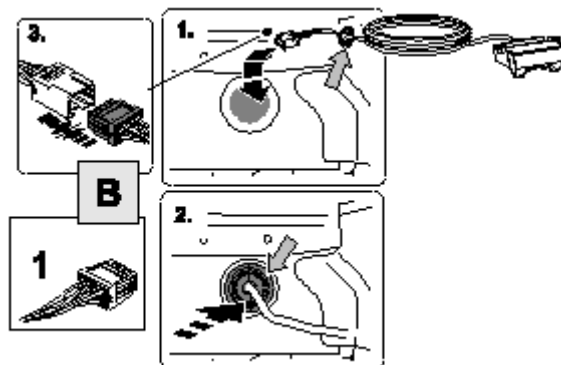

34. Plug the trailer patch (1) 18-way connector (C) into the ECU (2)(WLE70010).
35. Peel the backing off the adhesive tape from the rear of the ECU.
36. Mount the ECU sheet metal in location shown.

**Ensure the tape has good adhesion.**

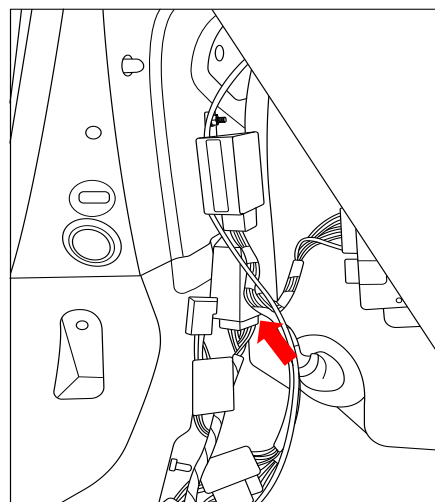

37. Connect the trailer patch ring terminal (A) to factory ground point.

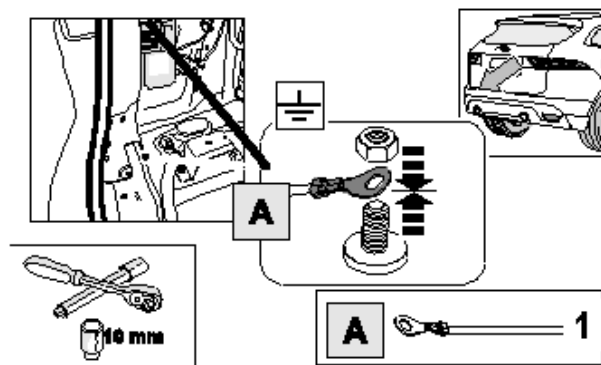



# TOWBAR INSTALLATION INSTRUCTIONS

PART NUMBER 03424RW

LANDROVER RANGEROVER EVOQUE L551 CL4

38. Locate the vehicle 8-way Pre-wire and connect the trailer patch harness (1) mating connector (E).

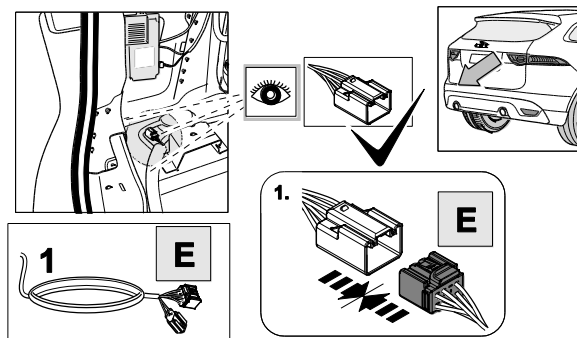

39. Secure harness with cable ties.  
40. Reinstall all removed parts from step 1-8 and 11, 22-28 in reverse ensure no rattles and squeaks.  
41. Test the trailer functionality with a test board.  
42. Place fitting instructions in the glovebox when finished.



# CUSTOMER INFORMATION

PLACE THESE INSTRUCTIONS IN THE  
VEHICLE'S GLOVEBOX AFTER INSTALLATION

**THANK YOU FOR PURCHASING HAYMAN REESE.  
WITH CORRECT MAINTENANCE AND CARE THIS PRODUCT WILL PROVIDE A  
LIFETIME OF TROUBLE-FREE OPERATION.**

## **i** TOWBAR MAINTENANCE AND CARE:

1. Hayman Reese recommend that the towbar LUG or TBM (tow ball Mount) Pull Pin and R-clip are removed and stored when not in use. Removal of LUG or TBM (tow ball mount) is advisable when not in use to assist with any of the following.
  - Ensure rear number plate is not obscured.
  - Allow maximum available departure angle and prevent any potential interference.
  - Prevent possible interference with vehicles reverse sensors or camera detecting a tow ball mount as an obstruction during reversing.
  - Removes towball mount as an obstruction for when moving around the rear of the vehicle.
2. Hayman Reese recommends routine inspection of your towbar to ensure trouble free towing.
  - Bolt security and tension should be regularly inspected and checked for correct tension. Replace any worn or defective parts with suitable grade & class fasteners. Inspection should be requested to coincide with vehicle major services.
3. It is the owner's responsibility to ensure towing and down ball weight capacities of the towing vehicle are not exceeded.
  - Towing and down ball weights allowable may differ according to model variations. Please refer to owner's manual or vehicle dealer to confirm exact rating for your vehicle model variant.
  - It is not uncommon for the vehicle tow rating to differ from the towbar rating. When this occurs, the lesser rating must be adhered to.
  - For vehicles fitted with enhanced vehicle functions that may be altered/changed when towing i.e Trailer sway mitigation, blind spot detection, adaptive cruise control etc. Please consult owner's manual to understand changes enabled when towing and after towing.

## **i** WARRANTY INFORMATION:

Hayman Reese Towbars are covered by a Lifetime Warranty.

Our goods come with guarantees that cannot be excluded under the Australian Consumer Law. You are entitled to a replacement or refund for a major failure and for compensation for any other reasonably foreseeable loss or damage. You are also entitled to have the goods repaired or replaced if the goods fail to be of acceptable quality and the failure does not amount to a major failure.

For further details please visit [www.haymanreese.com.au/warranty](http://www.haymanreese.com.au/warranty) or contact customer service on 1800 812 017 or [info@haymanreese.com.au](mailto:info@haymanreese.com.au).



# CUSTOMER INFORMATION

PLACE THESE INSTRUCTIONS IN THE VEHICLE'S GLOVEBOX AFTER INSTALLATION

## HAYMAN REESE SMART PIN

Your Hayman Reese towbar is equipped with Smart Pin technology to help reduce towbar tongue rattle in most driving conditions. Please ensure below instructions are understood and routine maintenance is carried out to ensure best towing experience.

**i** Regularly inspect for wear and check the tightness of the Smart Pin Nut. Follow instructions below to re-tighten the nut as necessary when movement and noise in the tow ball mount is noted.

- Before towing, ensure R-Clip is properly installed and Smart pin nut is installed and tensioned. Replacement parts are available from your Hayman Reese Distributor.

## TOWBALL MOUNT REMOVAL/INSTALLATION

### STEP 1

Insert Trailer Ball Mount (TBM) (a) into towbar hitchbox (b), aligning hole in TBM shank (c) with hole in hitchbox (d) (Fig. 1)

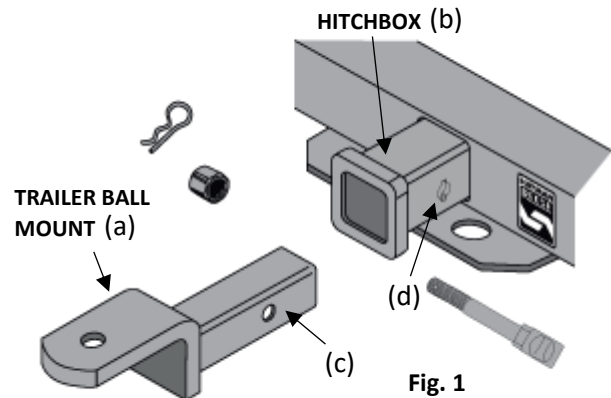

### STEP 2

Insert Smart Pin (e) through hole in hitchbox and hole in TBM shank (g); ensure the locators are inserted into the notches in the hitchbox (Fig. 2)

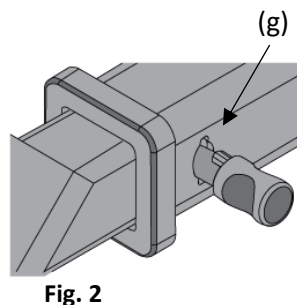

### STEP 3

Screw Smart Pin Nut (f) onto Smart Pin (g); tighten Smart Pin Nut until finger tight, ensuring TBM is restrained from up and down movement.

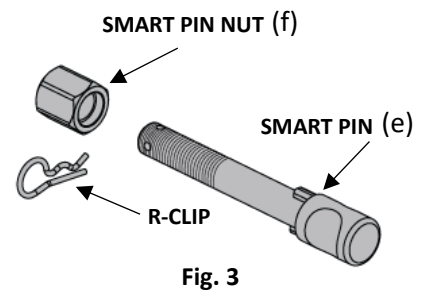

### STEP 4

Tighten Smart Pin Nut by turning nut a further 1/8th of a turn in the clockwise direction using a 24mm spanner (Fig. 4).

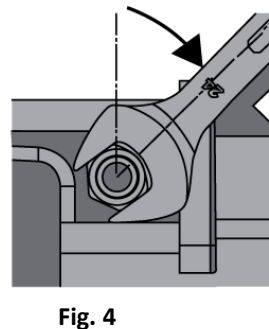

### STEP 5

Install Smart Pin R-Clip through the hole that provides best clearance or easiest access. (Fig. 5)

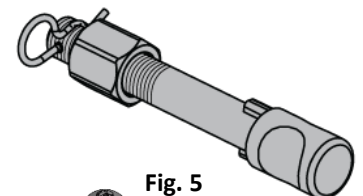

### STEP 6

Install towball onto TBM and tighten to **350 Nm** using a calibrated torque wrench (Fig. 6).

