



# TOWBAR INSTALLATION INSTRUCTIONS

PART NUMBER 03433RW

KIA SPORTAGE NQ5 CL4



## PRODUCT DETAILS:

Part Number:	03433RW	Maximum Towing Braked:	1900	kg
ECU Number:	04826	Maximum Towing Unbraked:	750	kg
Tail Harness Length Required:	400 mm	Maximum Static Ball Load:	190	kg
TBM/Lug Part Number:	21148			
Wiring Part Number:	102669-WL			

## FITTING DETAILS:

Towbar Installation Time:	60 Mins.	Hayman Reese SmartCODE Solution Required:	NO
Wiring Installation Time:	60 Mins.	RPA Disable/Other:	YES
Total Installation Time:	120 Mins.	Note:	
Bumper Cut Required:	Yes	<ul style="list-style-type: none"><li>RPA Disable Switch near Transmission Knob</li></ul>	



# TOWBAR INSTALLATION INSTRUCTIONS

PART NUMBER 03433RW

KIA SPORTAGE NQ5 CL4

**ENSURE THAT INSTRUCTIONS ARE UNDERSTOOD PRIOR TO FITMENT.**

## **i** BEFORE YOU START:

Hayman Reese recommends that instructions are read completely prior to fitment. Check all hardware items have been included refer to assembly diagram. Please ensure this towbar is only fitted to vehicle models as per Hayman Reese application guide ([www.haymanreese.com.au](http://www.haymanreese.com.au)).

### Bumper Cuts



Vehicle and bumper variations can and do occur during vehicle manufacture after initial towbar design. Fitment of towbar to vehicle and accuracy of bumper cut must be assessed prior to any bumper modifications made. Incorrect bumper cuts are not covered under Hayman Reese warranty.

**NOTE: Bumper cuts need to be approached with care, refer to notes below.**

- Bumper centreline – where the centreline of the bumper needs to be determined, the installer must assess centre point by measurement of bumper width or determining two symmetrical reference points to give centreline.
- Bumper edge – To assist with accurate bumper cut measurement, reference to the start of the bumper edge is now being commonly used.
  - Measure from bottom edge along bumper and around corner to the 70 mm point (Figure 1).
  - Do not measure from visible bumper front of corner, upwards (Figure 2).

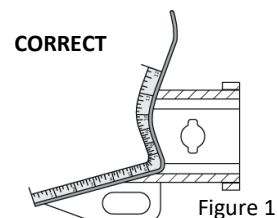

Figure 1

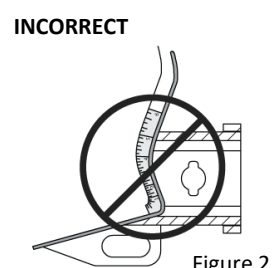

Figure 2

### Drilling

- For any required drilling during installation, ensure that the area is clear of fuel, electrical & other components that may be damaged.
- All holes drilled into the body panels shall have all burrs & swarf removed then coated with a suitable rust preventative paint.

### Bolts/Fasteners

- Ensure that all hardware is fastened to correct torque as specified in this fitting instruction.
- All fasteners supplied with this product are used to achieve a specified clamp loading. If replacement is required ensure that fasteners of the same grade and class are used.



**NOTE: Achieving correct torque is critical to proper installation and responsibility of the installer. Towbar failures attributed to tension issues from over tightening or under tightening are not covered by Hayman Reese warranty.**

### Product Labels

- a. Towbar load rating sticker provided with this product shall be conspicuously located on inside rear end of the driver's door.
- b. Powertrain Control Module (PCM)/Body Control Module (BCM) upgrade warning label will be provided in towbar kit for vehicles as required. Affix warning label in door and owner's handbook.

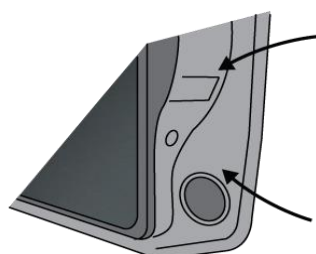

Place **Load Rating sticker** inside driver's door here

Place **Vehicle PCM/ BCM upgrade warning label** in door AND on front cover of owner's service handbook

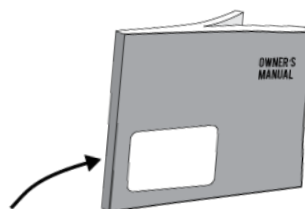

## **WARNING:**

**Do not, drill, cut, weld or otherwise modify the towbar.**

**FOR TOWING PURPOSES ONLY - This towbar is designed and tested by Hayman Reese to adhere to ADR 62/02 which provides only for the expected load demands of towing.**



# TOWBAR INSTALLATION INSTRUCTIONS

PART NUMBER 03433RW

KIA SPORTAGE NQ5 CL4

## TOWBAR ASSEMBLY DIAGRAM

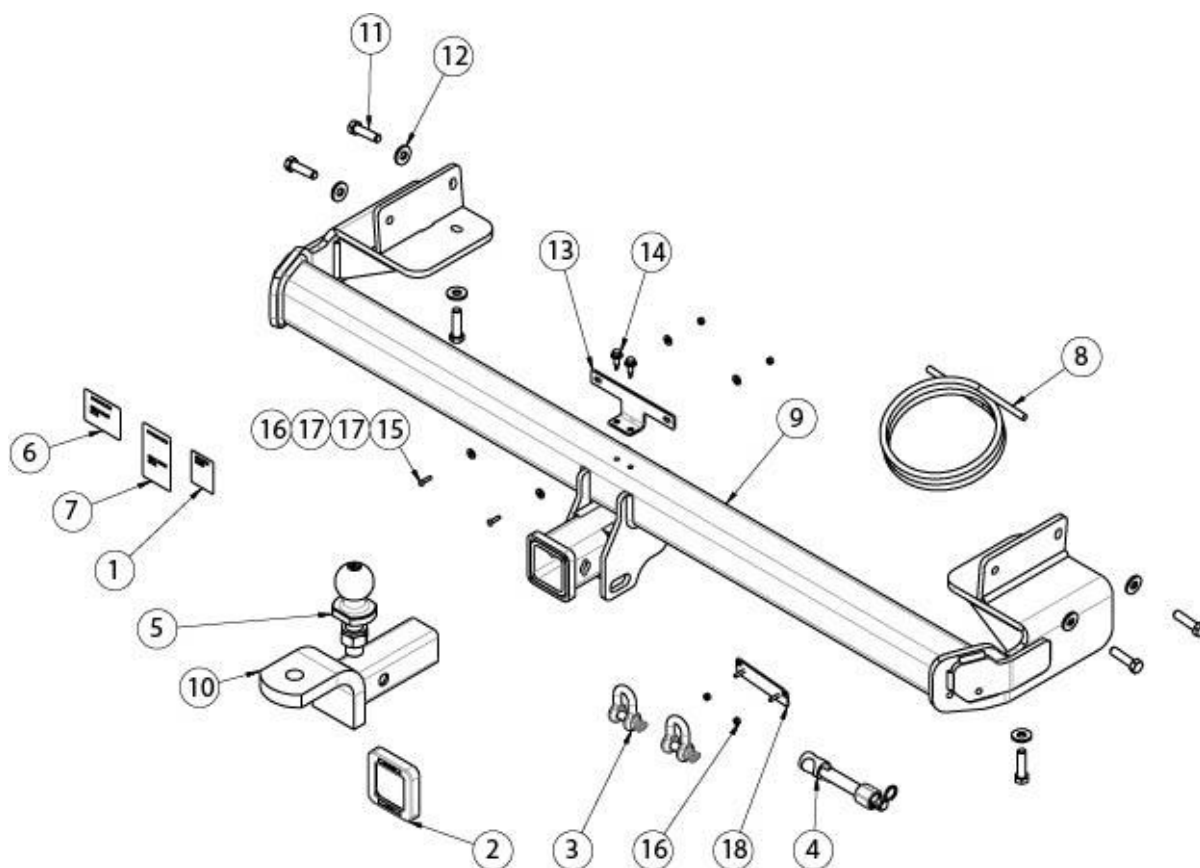

ITEM	DESCRIPTION	QTY
1	HAYMAN REESE LOGO STICKER	1
2	HITCH BOX COLLAR COVER	1
3	"D" SHACKLE 10mm	2
4	SMART PIN GOLD	1
5	TOWBALL 50mm	1
6	COMPLIANCE LABEL	1
7	LOAD RATING LABEL	1
8	WIRE LOOM	1
9	KIA SPORTAGE WELDED ASSEMBLY	1

ITEM	DESCRIPTION	QTY
10	TRAILER BALL MOUNT	1
11	SET SCREW HEX HD M10x45x1.25P	6
12	WASHER PLAIN M10x25x3	6
13	KEY SENSOR BRACKET	1
14	TEK SCREW 14-20 HEX HD 22mm	2
15	SCREW PAN HD M4x16x0.7P	2
16	NUT NYLOC HEX HD M4x0.7P	4
17	WASHER PLAIN 3/16x1/2x20	4
18	PLUG BRACKET	1



# TOWBAR INSTALLATION INSTRUCTIONS

PART NUMBER 03433RW

KIA SPORTAGE NQ5 CL4

1. Open the tail gate.  
Remove the plastic cover to expose the screw below.  
Remove 2x screws and disconnect the taillight.

Repeat for the other side.

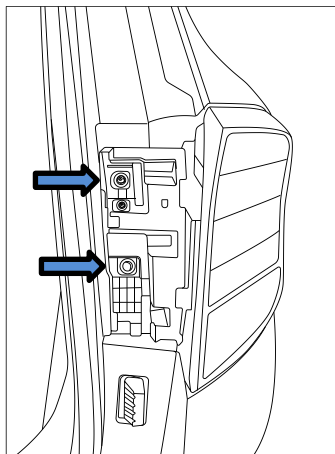

2. Remove 2x scrivet clips.

Repeat for the other side.

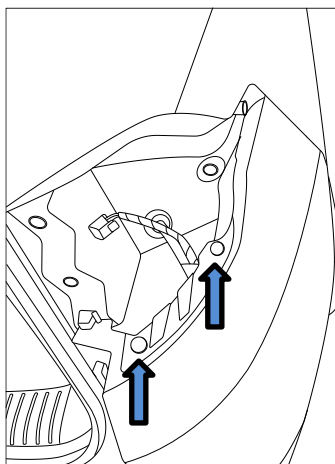

3. Remove 3x screws in the wheel arch liner.

Repeat for the other side.

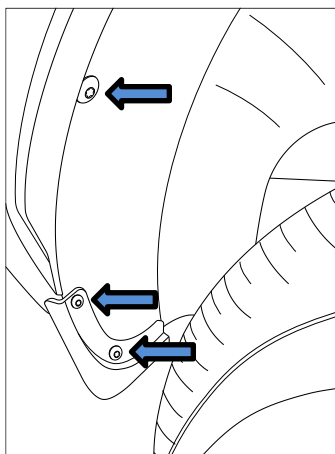



# TOWBAR INSTALLATION INSTRUCTIONS

PART NUMBER 03433RW

KIA SPORTAGE NQ5 CL4

- 
4. Carefully unclip the wheel arch.

Repeat for the other side.

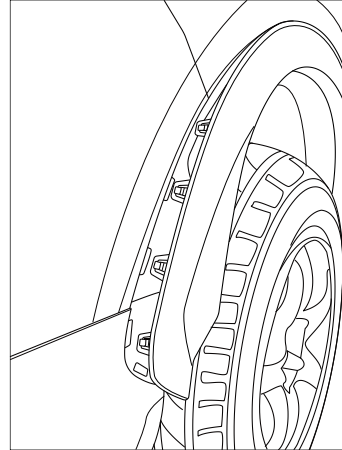

- 
5. On the driver side,  
Remove 3x scrivet clips under the bumper.

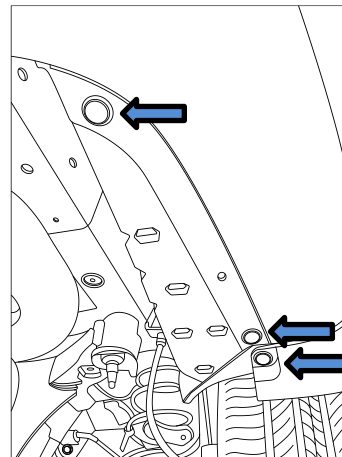

- 
6. On the passenger side,  
Remove 1x scrivet under the bumper.

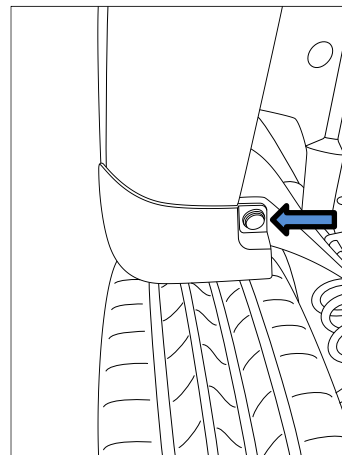

7. Remove 6x scrivet clips under the center section of the bumper.

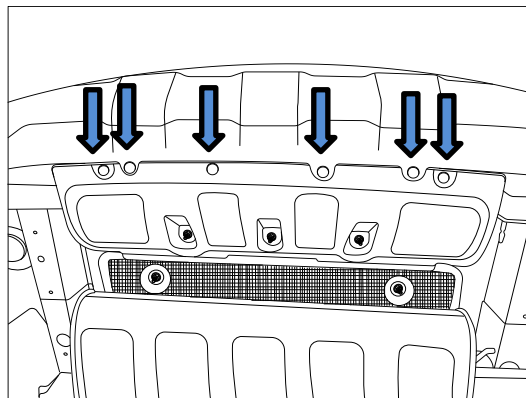

8. Remove 2x bolts behind the bumper.

Repeat for the other side.

Disconnect the wire loom and unclip and remove the bumper.

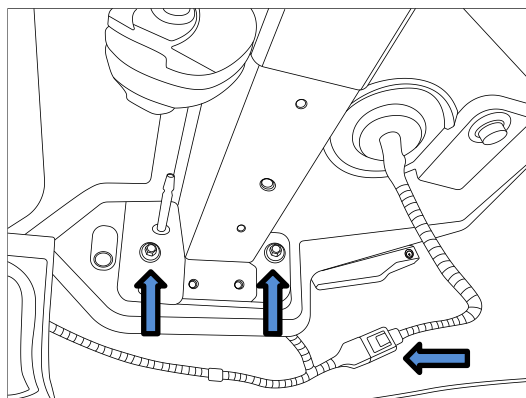

9. Fit the tow bar to the vehicle.  
Secure with 1x bolt and 1x washer under the side arm.

Repeat for the other side.

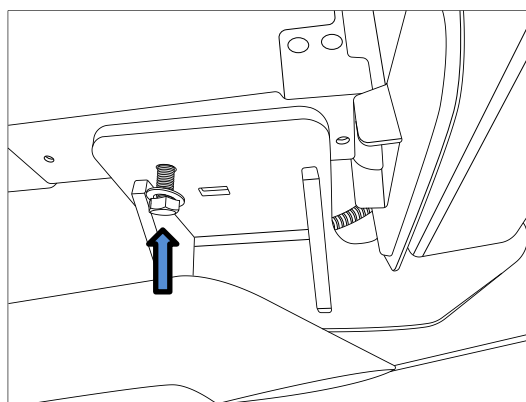



# TOWBAR INSTALLATION INSTRUCTIONS

PART NUMBER 03433RW

KIA SPORTAGE NQ5 CL4

10. Secure 2x bolts and 2x washers on the side arm.

Repeat for the other side.

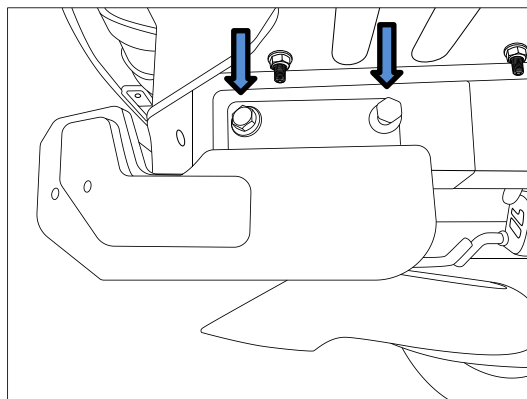

11. Torque fasteners as follows:

M10 x 1.25P = 68 Nm

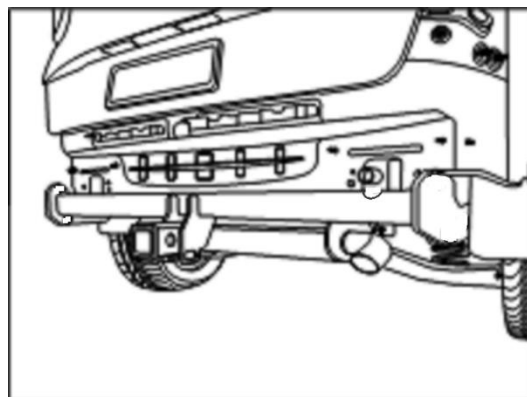

12. Remove 2x metal clip secure the impact beam to the bumper.

Remove and discard the impact beam.

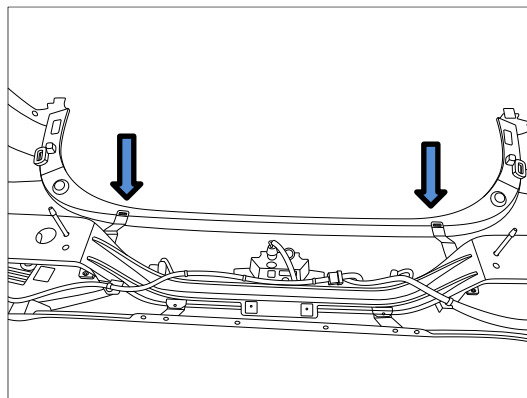



# TOWBAR INSTALLATION INSTRUCTIONS

PART NUMBER 03433RW

KIA SPORTAGE NQ5 CL4

13. Place masking tape on the bumper outer skin  
Mark and cut out an area as shown to clear the  
hitch box

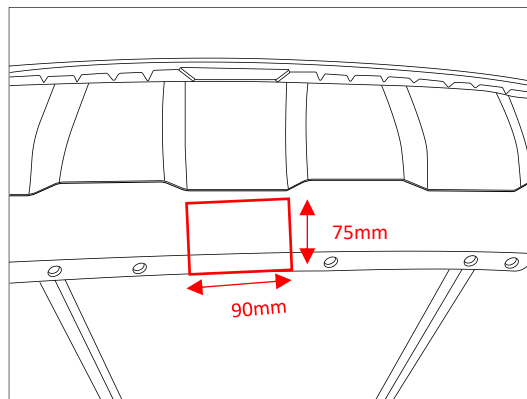

14. Mark and cut out an area in the center plastic trim  
to clear the hitch box. As shown

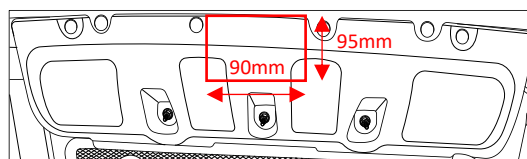

15. Mark and cut out an area in the RHS plastic trim to  
clear sidearm. As shown

Cut Dimensions: 70mm (W) x 94mm (H).

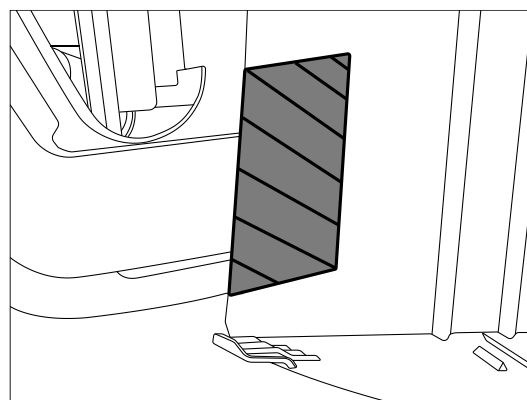





# TOWBAR INSTALLATION INSTRUCTIONS

PART NUMBER 03433RW

KIA SPORTAGE NQ5 CL4

16. Locate the plug bracket and ensure the harness cable length is long enough.  
Drill 2x  $\varnothing$ 5mm holes 69mm apart.  
Place the plug bracket on the bumper.  
Reassembly the bumper and all other parts in reverse order of removal.  
Secure all fasteners and clips, ensuring there are no squeaks or rattles

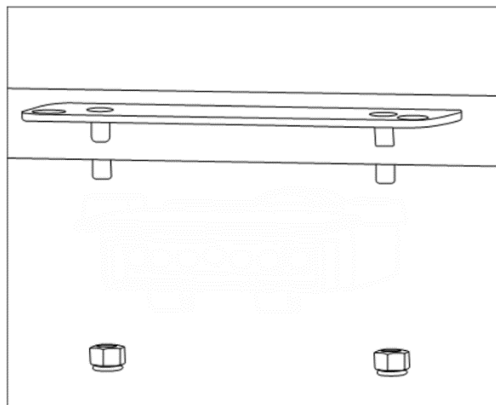

## IMPORTANT

Due to possible vehicle variations, always confirm any noted vehicle colour wires with a multi-meter to ensure the correct function is identified before soldering or scotch locking. For vehicle wires denoted with two colours (example; RED/GREEN) the first colour will always be the main wire colour while the second colour is the thinner trace colour on the wire.

17. In the luggage compartment, remove the floor carpet (1).
18. Fold down the rear seats (2).
19. Remove Rear Scuff Trim (3).

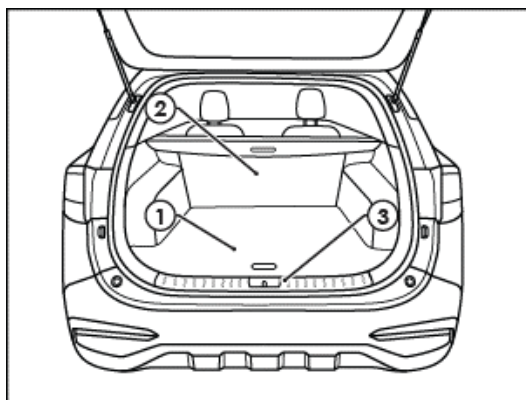

20. Remove rear seat cushion (1) by pulling first in an upward direction, then push back towards the rear of vehicle to release the secondary centre mount.
21. Disconnect the vehicle connectors underneath the rear seat cushion.

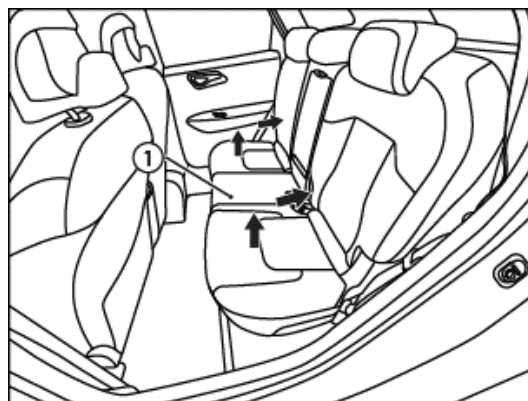

22. If installed, disconnect the LHS seat release cable (1) from behind the LHS rear seat (2).
23. Remove the bolt (3) securing the left rear seat (2).

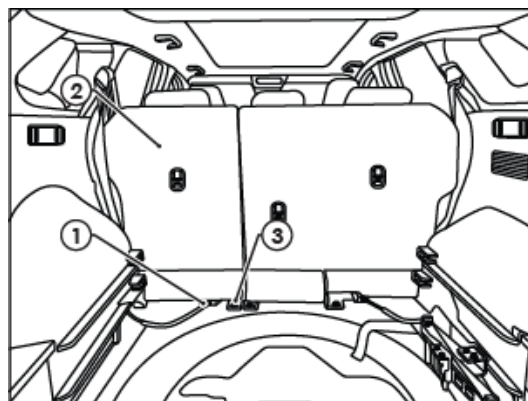

24. Dislodge the weather seal (1) around the LHS rear door.
25. Remove the LHS rear door sill trim (2).

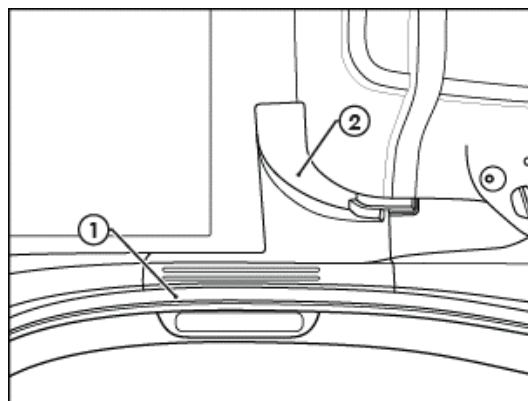



# TOWBAR INSTALLATION INSTRUCTIONS

PART NUMBER 03433RW

KIA SPORTAGE NQ5 CL4

26. Disconnect the seat belt buckle connector (1).
27. Remove the 3 remaining mounting bolts (2) holding the left rear seat (3).
28. Remove the left rear seat (3).

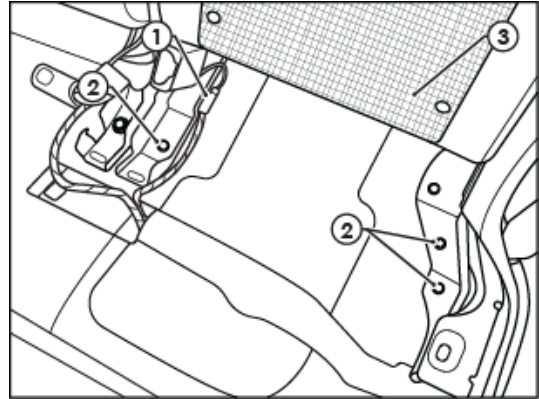

29. Remove the two screws (1) from the front of the left rear luggage compartment trim (2).
30. Remove the plastic cover (3) and remove the seat belt mounting bolt.

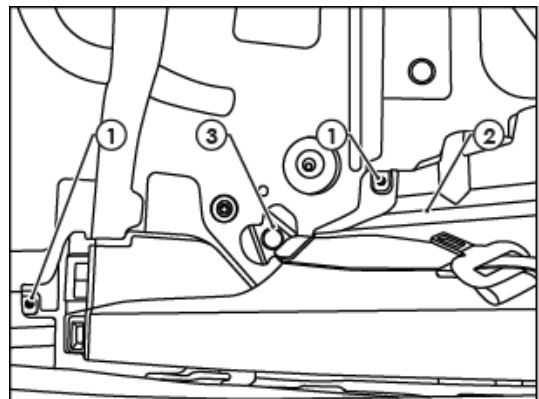

31. Remove screws (1) from the left rear luggage compartment trim (2).
32. Dislodge the left rear luggage compartment trim (2) and disconnect any harness connectors from behind the trim.
33. Remove the left luggage compartment trim (2).

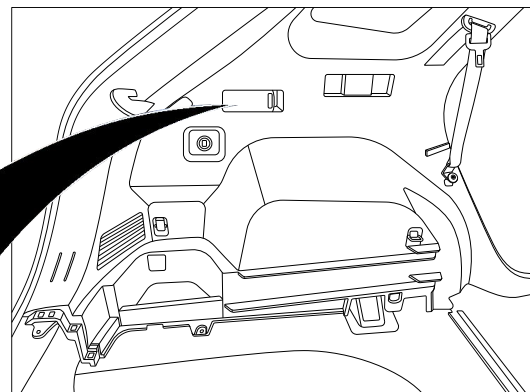
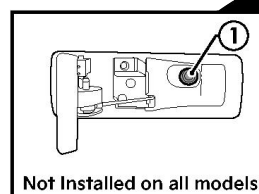

34. Locate and discard the 26mm grommet (1).
35. Remove the tape securing the 6-Way Trailer Pre-Wire Connector (2) from the vehicle harness.

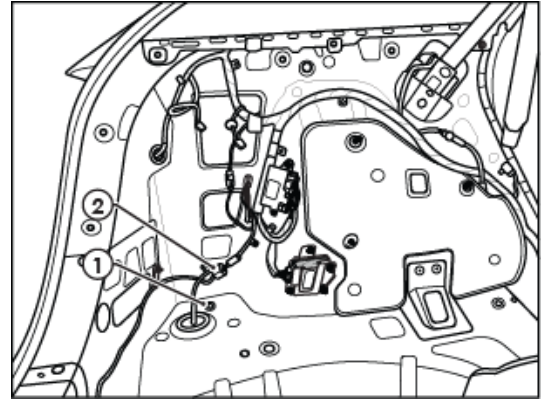

36. From outside vehicle, feed the external harness (1) through the previously exposed 26mm hole on the rear left underside of the vehicle.
37. On the inside of the vehicle connect the two external harness 6-way connectors (2) to the two internal harness 6-way connectors (3).

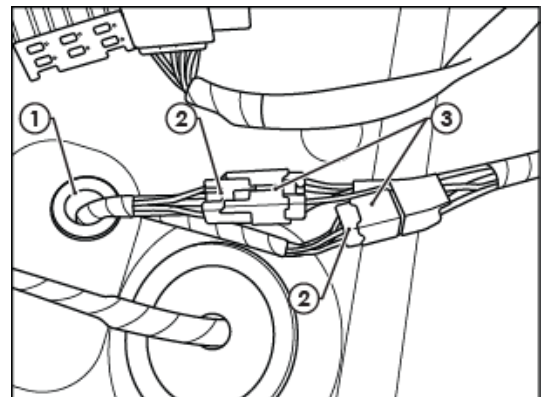

38. Behind the LHS rear panel, clean ECU mounting location (1) shown and base of ECU (2) using supplied cleaning pad.
39. Connect the Trailer Harness 12-way connector (3) to ECU (2) and mount in the location shown using the supplied Double-Sided Tape (4).
40. Secure Trailer Harness (5) to existing vehicle harness using supplied 200mm cable ties.

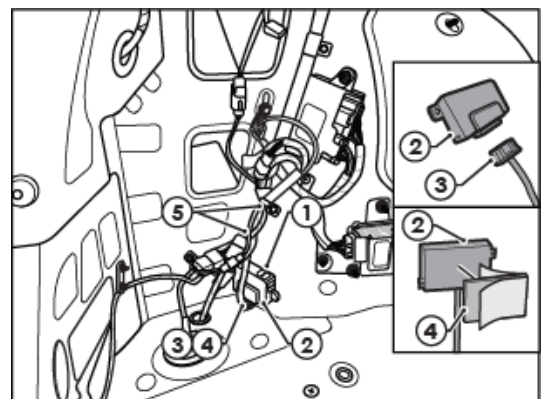



# TOWBAR INSTALLATION INSTRUCTIONS

PART NUMBER 03433RW

KIA SPORTAGE NQ5 CL4

41. Route the internal Harness (1) following the vehicle harness.
42. Connect the 6-Way male connector (2) to the Vehicle 6-way female Pre-Wire connector.
43. Connect the Internal Harness ring terminal to the vehicle earth point (3) using the existing vehicle fastener.

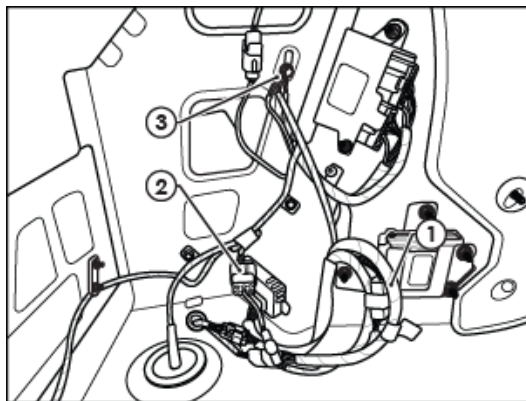

44. At the Rear of the Vehicle connect the LHS Tail lamp connector to the LHS Tail Lamp Patch.
45. Route the Trailer Wiring Harness across towards the RHS of the vehicle and connect the RHS Tail Lamp Connector to the RHS Tail Lamp Patch.

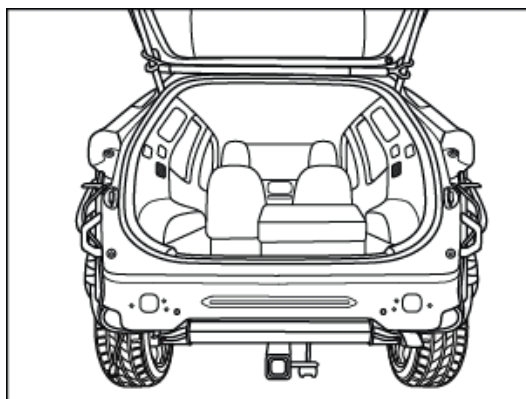

46. Connect the tail harness (tail length 400mm) 8-way connector (1) to the trailer patch mating 8-way connector (2).
47. Secure all harness using supplied cable ties.
48. Apply silicone grease (3) (not provided) to the blue connectors to prevent water ingress.
49. Re-fit all removed parts and secure all fasteners (1-8 and 18-34 in reverse). Ensuring there are no squeaks or rattles.
50. Test the trailer patch function using a light board or multimeter.
51. Place the fitting instructions in the glove box after fitment.

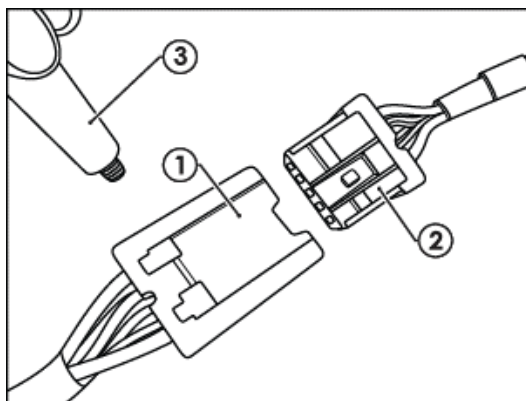



# CUSTOMER INFORMATION

PLACE THESE INSTRUCTIONS IN THE  
VEHICLE'S GLOVEBOX AFTER INSTALLATION

**THANK YOU FOR PURCHASING HAYMAN REESE.  
WITH CORRECT MAINTENANCE AND CARE THIS PRODUCT WILL PROVIDE A  
LIFETIME OF TROUBLE-FREE OPERATION.**

## **i** TOWBAR MAINTENANCE AND CARE:

1. Hayman Reese recommend that the towbar LUG or TBM (tow ball Mount) Pull Pin and R-clip are removed and stored when not in use. Removal of LUG or TBM (tow ball mount) is advisable when not in use to assist with any of the following.
  - Ensure rear number plate is not obscured.
  - Allow maximum available departure angle and prevent any potential interference.
  - Prevent possible interference with vehicles reverse sensors or camera detecting a tow ball mount as an obstruction during reversing.
  - Removes towball mount as an obstruction for when moving around the rear of the vehicle.
2. Hayman Reese recommends routine inspection of your towbar to ensure trouble free towing.
  - Bolt security and tension should be regularly inspected and checked for correct tension. Replace any worn or defective parts with suitable grade & class fasteners. Inspection should be requested to coincide with vehicle major services.
3. It is the owner's responsibility to ensure towing and down ball weight capacities of the towing vehicle are not exceeded.
  - Towing and down ball weights allowable may differ according to model variations. Please refer to owner's manual or vehicle dealer to confirm exact rating for your vehicle model variant.
  - It is not uncommon for the vehicle tow rating to differ from the towbar rating. When this occurs, the lesser rating must be adhered to.
  - For vehicles fitted with enhanced vehicle functions that may be altered/changed when towing i.e Trailer sway mitigation, blind spot detection, adaptive cruise control etc. Please consult owner's manual to understand changes enabled when towing and after towing.

## **i** WARRANTY INFORMATION:

Hayman Reese Towbars are covered by a Lifetime Warranty.

Our goods come with guarantees that cannot be excluded under the Australian Consumer Law. You are entitled to a replacement or refund for a major failure and for compensation for any other reasonably foreseeable loss or damage. You are also entitled to have the goods repaired or replaced if the goods fail to be of acceptable quality and the failure does not amount to a major failure.

For further details please visit [www.haymanreese.com.au/warranty](http://www.haymanreese.com.au/warranty) or contact customer service on 1800 812 017 or [info@haymanreese.com.au](mailto:info@haymanreese.com.au).



# CUSTOMER INFORMATION

PLACE THESE INSTRUCTIONS IN THE VEHICLE'S GLOVEBOX AFTER INSTALLATION

## HAYMAN REESE SMART PIN

Your Hayman Reese towbar is equipped with Smart Pin technology to help reduce towbar tongue rattle in most driving conditions. Please ensure below instructions are understood and routine maintenance is carried out to ensure best towing experience.

**i** Regularly inspect for wear and check the tightness of the Smart Pin Nut. Follow instructions below to re-tighten the nut as necessary when movement and noise in the tow ball mount is noted.

- Before towing, ensure R-Clip is properly installed and Smart pin nut is installed and tensioned. Replacement parts are available from your Hayman Reese Distributor.

## TOWBALL MOUNT REMOVAL/INSTALLATION

### STEP 1

Insert Trailer Ball Mount (TBM) (a) into towbar hitchbox (b), aligning hole in TBM shank (c) with hole in hitchbox (d) (Fig. 1)

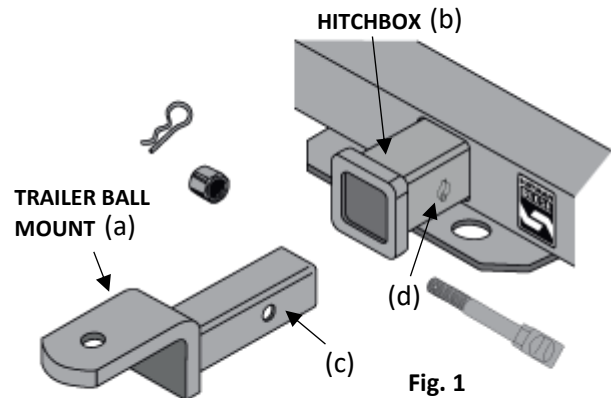

### STEP 2

Insert Smart Pin (e) through hole in hitchbox and hole in TBM shank (g); ensure the locators are inserted into the notches in the hitchbox (Fig. 2)

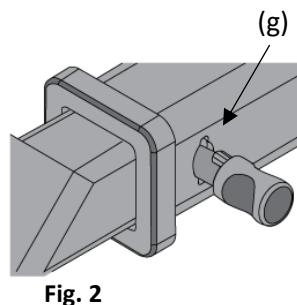

### STEP 3

Screw Smart Pin Nut (f) onto Smart Pin (g); tighten Smart Pin Nut until finger tight, ensuring TBM is restrained from up and down movement.

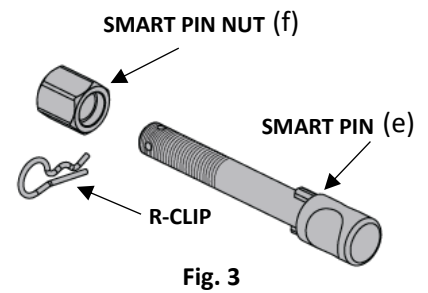

### STEP 4

Tighten Smart Pin Nut by turning nut a further 1/8th of a turn in the clockwise direction using a 24mm spanner (Fig. 4).

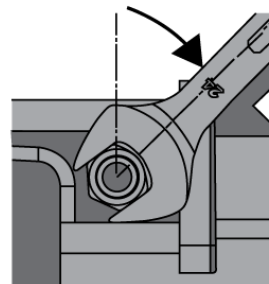

### STEP 5

Install Smart Pin R-Clip through the hole that provides best clearance or easiest access. (Fig. 5)

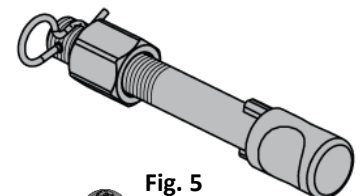

### STEP 6

Install towball onto TBM and tighten to **350 Nm** using a calibrated torque wrench (Fig. 6).

