



TOWBAR INSTALLATION INSTRUCTIONS

PART NUMBER 03443RW

NISSAN PATROL Y62 SERIES 5 CL4



PRODUCT DETAILS:

Part Number:	03443RW	Maximum Towing Braked:	3500	kg
ECU Number:	N/A	Maximum Towing Unbraked:	750	kg
Tail Harness Length Required:	1800 mm	Maximum Static Ball Load:	350	kg
TBM/Lug Part Number:	21325			
Wiring Part Number:	102487-WL			

FITTING DETAILS:

Towbar Installation Time:	100 Mins.	Hayman Reese SmartCODE Solution Required:	NO
Wiring Installation Time:	40 Mins.	RPA Disable/Other:	NO
Total Installation Time:	140 Mins.	Note:	
Bumper Cut Required:	Yes	<ul style="list-style-type: none">RPA is disabled by pressing "Pmod" on infotainment screen.	



TOWBAR INSTALLATION INSTRUCTIONS

PART NUMBER 03443RW

NISSAN PATROL Y62 SERIES 5 CL4

ENSURE THAT INSTRUCTIONS ARE UNDERSTOOD PRIOR TO FITMENT.

i BEFORE YOU START:

Hayman Reese recommends that instructions are read completely prior to fitment. Check all hardware items have been included refer to assembly diagram. Please ensure this towbar is only fitted to vehicle models as per Hayman Reese application guide (www.haymanreese.com.au).

Bumper Cuts



Vehicle and bumper variations can and do occur during vehicle manufacture after initial towbar design. Fitment of towbar to vehicle and accuracy of bumper cut must be assessed prior to any bumper modifications made. Incorrect bumper cuts are not covered under Hayman Reese warranty.

NOTE: Bumper cuts need to be approached with care, refer to notes below.

- Bumper centreline – where the centreline of the bumper needs to be determined, the installer must assess centre point by measurement of bumper width or determining two symmetrical reference points to give centreline.
- Bumper edge – To assist with accurate bumper cut measurement, reference to the start of the bumper edge is now being commonly used.
 - Measure from bottom edge along bumper and around corner to the 70 mm point (Figure 1).
 - Do not measure from visible bumper front of corner, upwards (Figure 2).

CORRECT

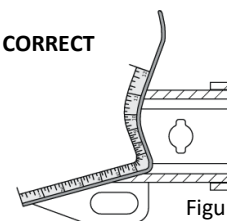

Figure 1

INCORRECT

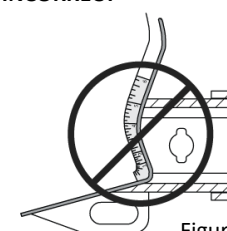

Figure 2

Drilling

- For any required drilling during installation, ensure that the area is clear of fuel, electrical & other components that may be damaged.
- All holes drilled into the body panels shall have all burrs & swarf removed then coated with a suitable rust preventative paint.

Bolts/Fasteners

- Ensure that all hardware is fastened to correct torque as specified in this fitting instruction.
- All fasteners supplied with this product are used to achieve a specified clamp loading. If replacement is required ensure that fasteners of the same grade and class are used.



NOTE: Achieving correct torque is critical to proper installation and responsibility of the installer. Towbar failures attributed to tension issues from over tightening or under tightening are not covered by Hayman Reese warranty.

Product Labels

- a. Towbar load rating sticker provided with this product shall be conspicuously located on inside rear end of the driver's door.
- b. Powertrain Control Module (PCM)/Body Control Module (BCM) upgrade warning label will be provided in towbar kit for vehicles as required. Affix warning label in door and owner's handbook.

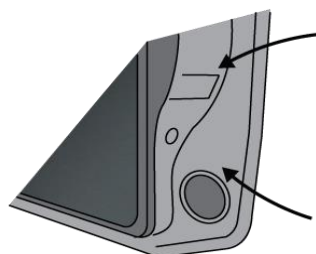

Place **Load Rating sticker** inside driver's door here

Place **Vehicle PCM/ BCM upgrade warning label** in door AND on front cover of owner's service handbook

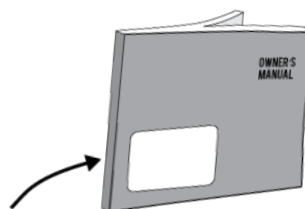

WARNING:

Do not, drill, cut, weld or otherwise modify the towbar.

FOR TOWING PURPOSES ONLY - This towbar is designed and tested by Hayman Reese to adhere to ADR 62/02 which provides only for the expected load demands of towing.



TOWBAR INSTALLATION INSTRUCTIONS

PART NUMBER 03443RW

NISSAN PATROL Y62 SERIES 5 CL4

i TOWBAR ASSEMBLY DIAGRAM

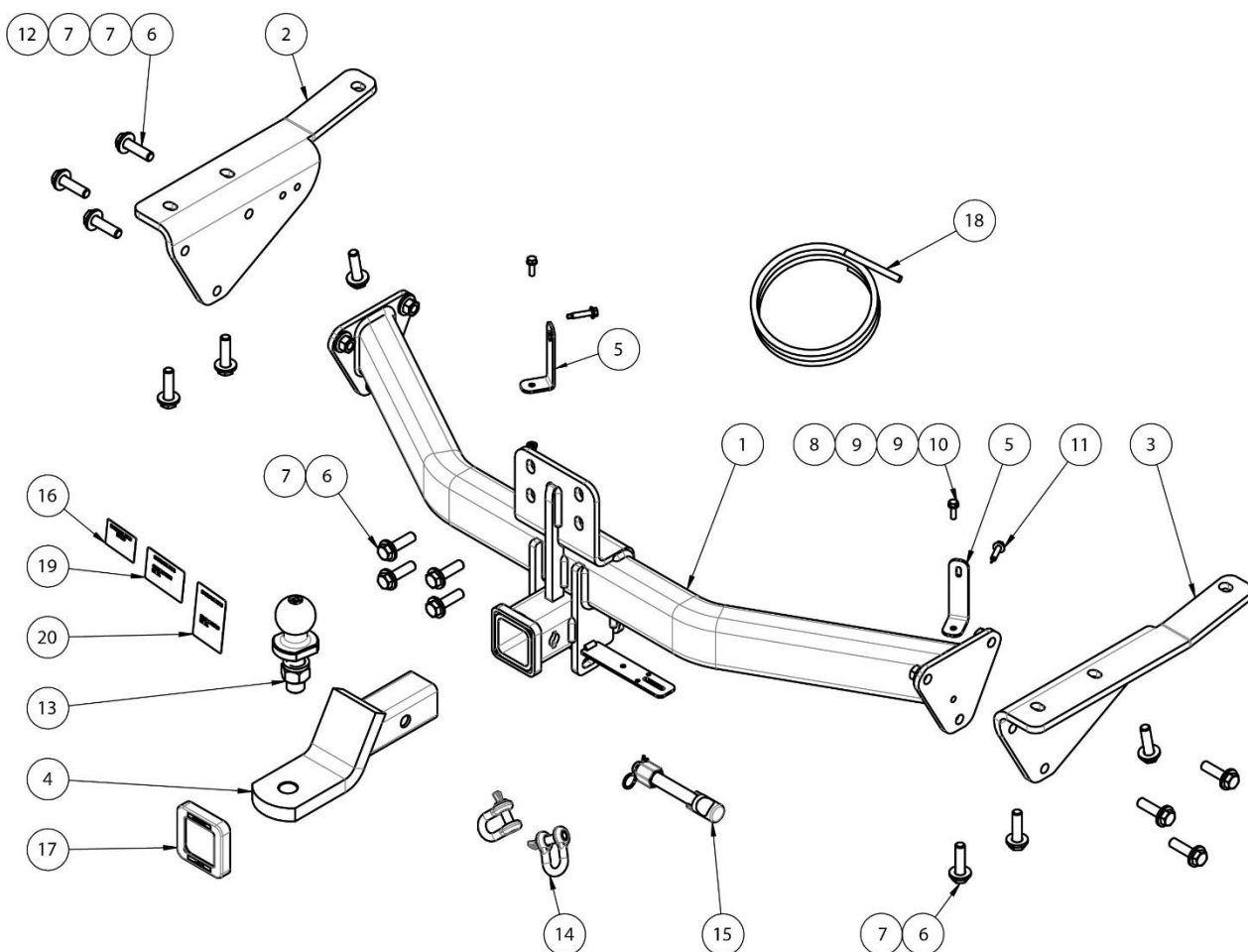

ITEM	DESCRIPTION	QTY
1	NISSAN PATROL Y62 WELDED ASSEMBLY	1
2	SIDE ARM LHS	1
3	SIDE ARM RHS	1
4	TRAILER BALL MOUNT	1
5	BUMPER TAB	2
6	SET SCREW HEX HD M12x45x1.25P	16
7	WASHER PLAIN 1/2"	22
8	NUT HEX HD M6x1.0P	2
9	WASHER FLAT M6x12.5x1.2	4
10	SET SCREW HEX HD M6x20x1.2P	2

ITEM	DESCRIPTION	QTY
11	TEK SCREW 14-20 HEX HD 22mm	2
12	NUT HEX HD M12x1.25P	6
13	TOWBALL 50mm	1
14	"D" SHACKLE 10mm	2
15	SMART PIN GOLD	1
16	H.R STICKER	1
17	HITCH BOX COLLAR COVER	1
18	16 STRANDx0.3mm 7 CORE CABLE	1
19	COMPLIANCE LABEL	1
20	LOAD RATING LABEL	1



TOWBAR INSTALLATION INSTRUCTIONS

PART NUMBER 03443RW

NISSAN PATROL Y62 SERIES 5 CL4

1. Remove the tail light cover.
Remove 3x screws.

Repeat for the other side.

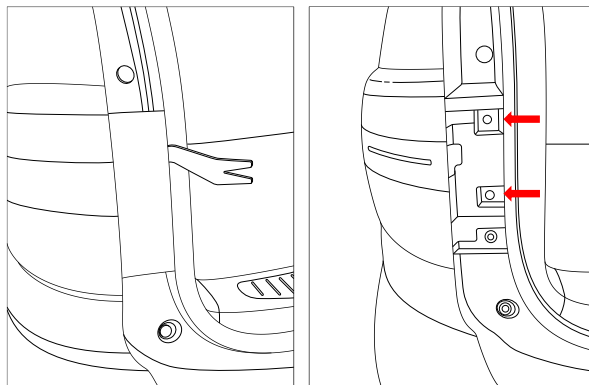

2. Remove the tail light by pulling side way.
Disconnect tail light wire.
Remove 1x scrivet clip.

Repeat for the other side.

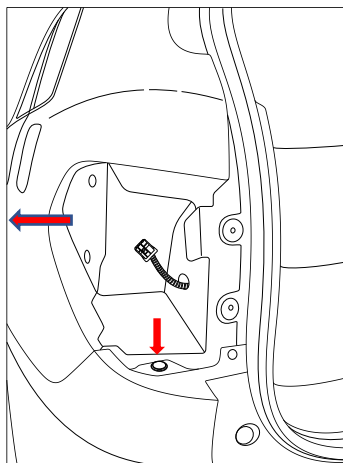

3. Remove 6x torx screws on the mud guard.
Peel the inner wheel arch lining and remove 1x screw.

Repeat for the other side.

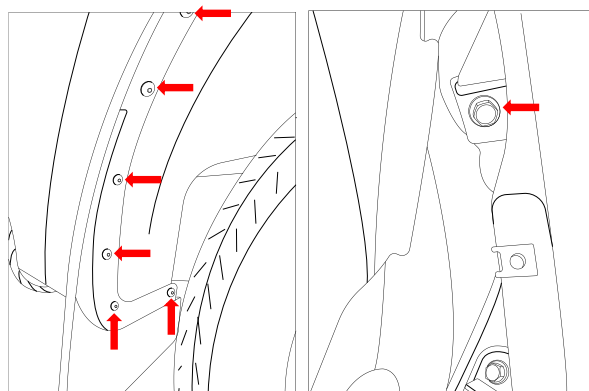



TOWBAR INSTALLATION INSTRUCTIONS

PART NUMBER 03443RW

NISSAN PATROL Y62 SERIES 5 CL4

-
4. Lift the vehicle.
Remove 2x screws behind the mud guard.

Repeat for the other side.

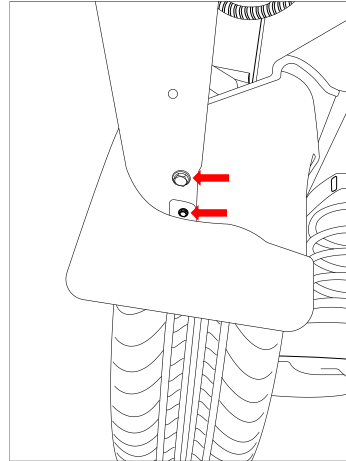

-
5. Remove 2x screws under the bumper.

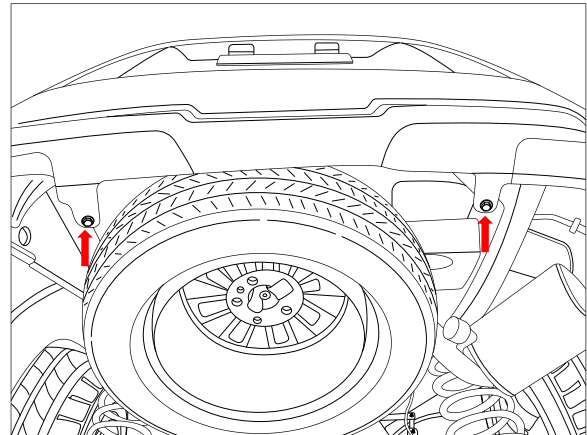

-
6. Unclip the bumper and disconnect the sensor harness from the driver side.

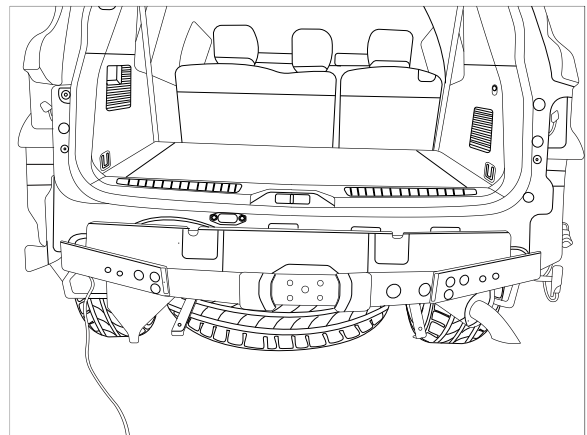



TOWBAR INSTALLATION INSTRUCTIONS

PART NUMBER 03443RW

NISSAN PATROL Y62 SERIES 5 CL4

7. Remove 5x bolts and discard the recovery bracket.

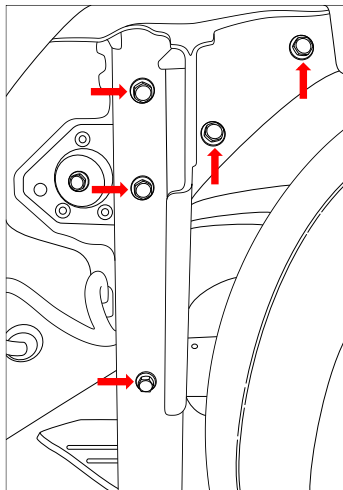

8. Using the wheel tool kit and lower the spare wheel.

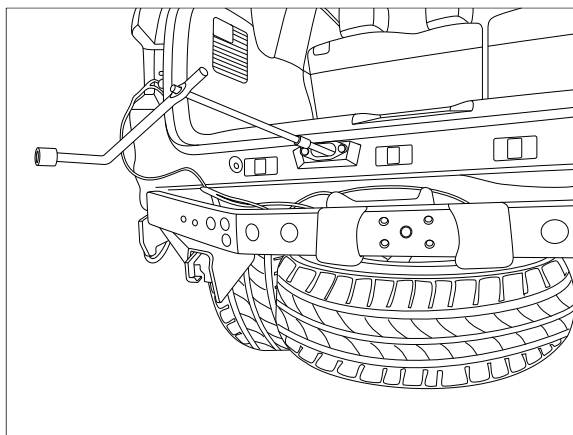

9. Fit the side arm bracket to the vehicle.
Loosely secure with 3x M12 bolts with 3x washer.

Repeat for the other side.

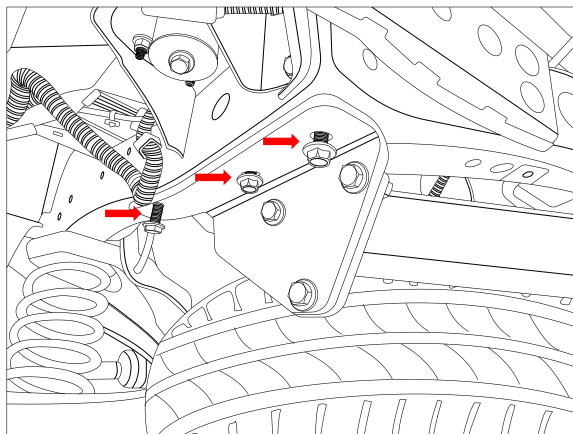



TOWBAR INSTALLATION INSTRUCTIONS

PART NUMBER 03443RW

NISSAN PATROL Y62 SERIES 5 CL4

10. Fit the cross bar between the side arms.

Secure 3x M12 bolts with 6x washer and 3x nuts to each side arm.

Secure 4x M12 bolts with 4x washer to center of the cross bar.

TORQUE ALL M12 FASTENER TO 90Nm

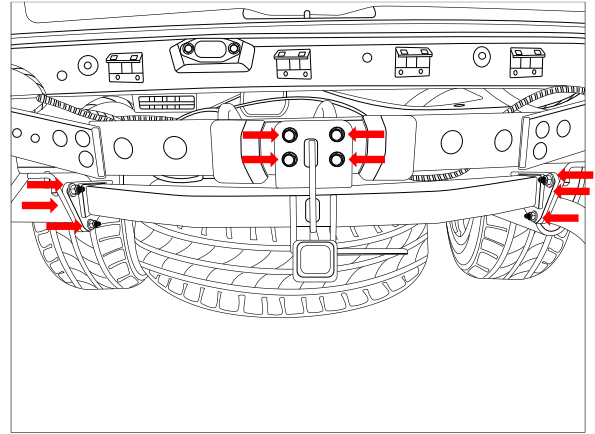

11. Fit the bumper tab bracket to the cross tube.

Secure 1x tek screw.

Repeat for the side

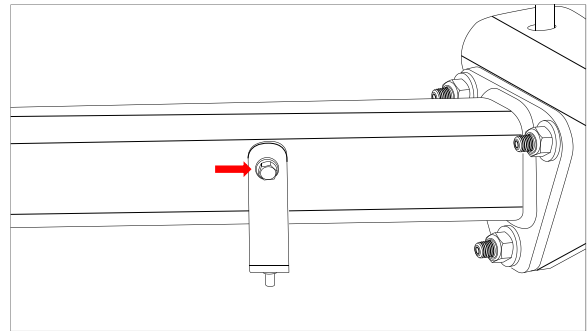

12. Cut out an area 95mm x 55mm from the center of the bumper.

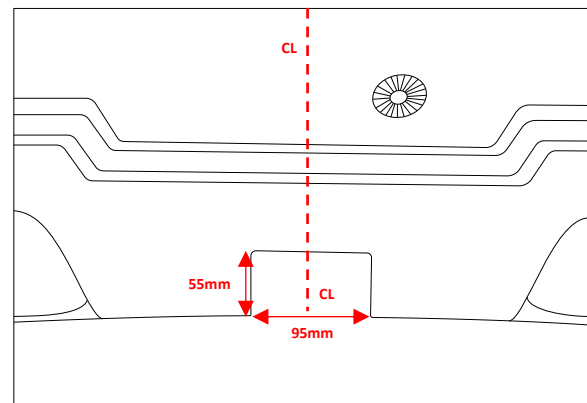



TOWBAR INSTALLATION INSTRUCTIONS

PART NUMBER 03443RW

NISSAN PATROL Y62 SERIES 5 CL4

13. Remove the tab on the inner skin of the bumper.

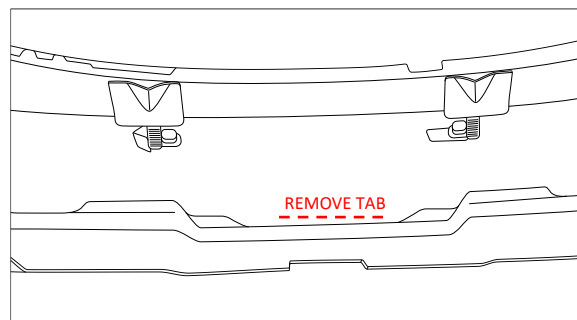

14. In the luggage compartment remove the 2x anchor points.

15. Lift the tool lid cover and remove the tool tray.

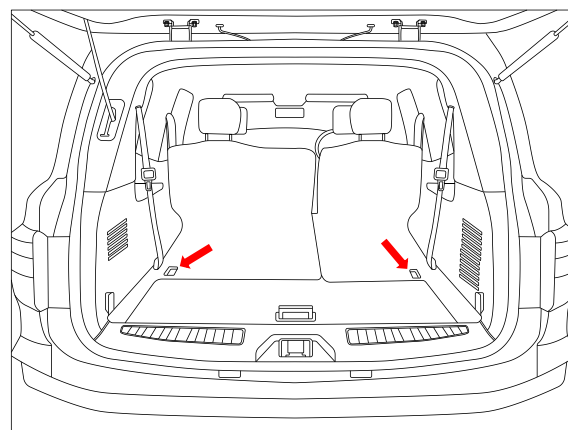

16. Remove the 2x bolts for both LHS and RHS plastic trims and remove the trims.

17. Remove the 2x bolts that secures the straps for the tool lid cover

18. Remove the rear sill trim.

19. Fold the LHS second row seat forward.

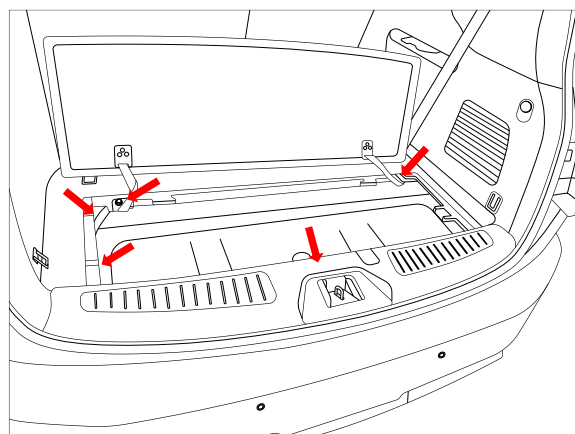

20. Remove the bolt holding both LHS Rear Passenger Seat belts.
21. Remove the LHS rear cargo hooks.
22. Carefully dislodge LHS trim and the disconnect the 2-way AUX connector.
23. Remove the LHS trim.

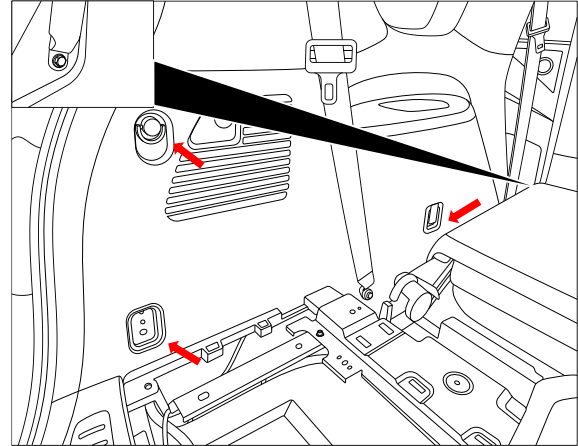

24. Drill a $\varnothing 30\text{mm}$ hole in the area indicated.



IMPORTANT:

Look underneath prior to drilling. Ensure that hole is clear of the spare tyre and wiring.

Remove all sharp edges and apply rust inhibitor.

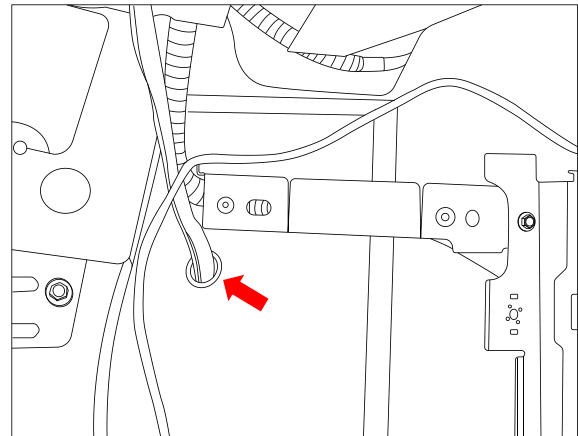

25. Mount the tail (1800mm) to the plug bracket using M4 fasteners (not supplied), route the tail towards the previous drilled hole and feed the blue connector through the hole.
26. Slide the grommet to desired location and secure with cable tie

Keep harness routing away from sharp edges moving parts and places of extreme heat.

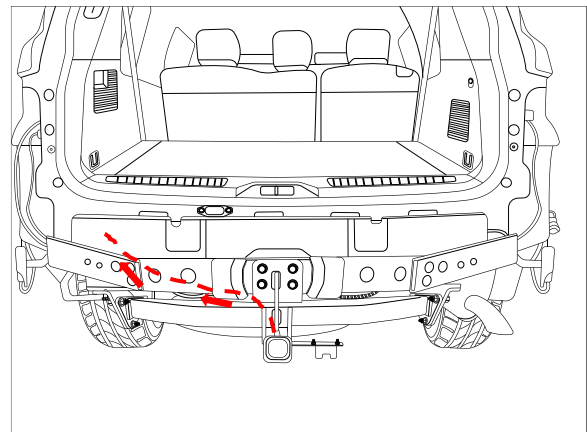



TOWBAR INSTALLATION INSTRUCTIONS

PART NUMBER 03443RW

NISSAN PATROL Y62 SERIES 5 CL4

27. Locate the 6-way Pre-wire connector at the front of the LHS wheel arch.
28. Remove the tape securing the Pre-wire connector and patch the trailer patch 102487-WL into the mating connector.
29. Connect the ground ring terminal to the vehicle factory ground point.
Route the trailer patch towards the previously ran tail harness blue connector rear for the vehicle following the main vehicle harness.

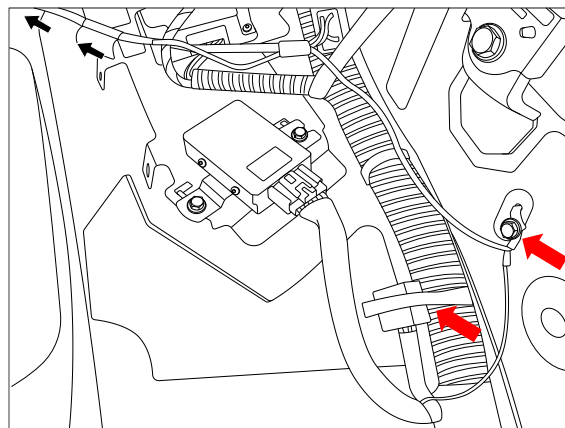

30. Connect the tail harness (tail length 1800mm) 8-way connector to the trailer patch mating connector.

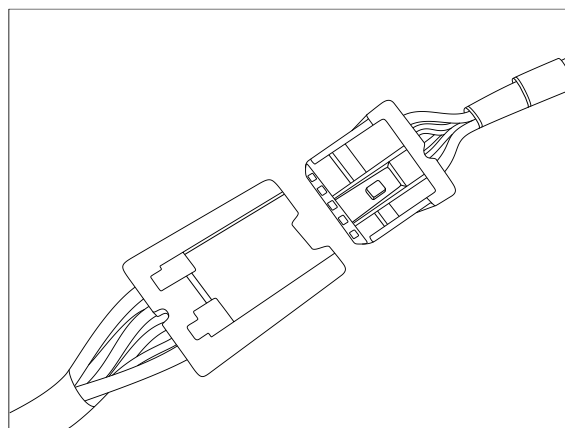

31. Reassemble all removed parts and secure all fasteners from steps 1 to 6, and 14 to 23 in reverse ensuring there are no squeaks or rattles.
32. Test the trailer wiring harness function using a light board or multimeter.
33. RPA is disabled by pressing "**Pmod**" on infotainment screen.
34. Place fitting instructions in the glove box after fitment.

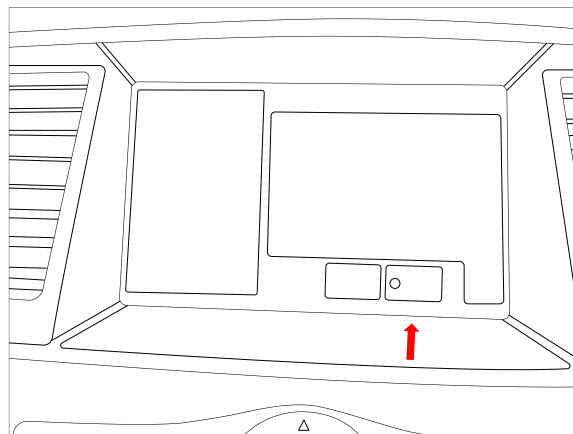



CUSTOMER INFORMATION

PLACE THESE INSTRUCTIONS IN THE
VEHICLE'S GLOVEBOX AFTER INSTALLATION

**THANK YOU FOR PURCHASING HAYMAN REESE.
WITH CORRECT MAINTENANCE AND CARE THIS PRODUCT WILL PROVIDE A
LIFETIME OF TROUBLE-FREE OPERATION.**

i TOWBAR MAINTENANCE AND CARE:

1. Hayman Reese recommend that the towbar LUG or TBM (tow ball Mount) Pull Pin and R-clip are removed and stored when not in use. Removal of LUG or TBM (tow ball mount) is advisable when not in use to assist with any of the following.
 - Ensure rear number plate is not obscured.
 - Allow maximum available departure angle and prevent any potential interference.
 - Prevent possible interference with vehicles reverse sensors or camera detecting a tow ball mount as an obstruction during reversing.
 - Removes towball mount as an obstruction for when moving around the rear of the vehicle.
2. Hayman Reese recommends routine inspection of your towbar to ensure trouble free towing.
 - Bolt security and tension should be regularly inspected and checked for correct tension. Replace any worn or defective parts with suitable grade & class fasteners. Inspection should be requested to coincide with vehicle major services.
3. It is the owner's responsibility to ensure towing and down ball weight capacities of the towing vehicle are not exceeded.
 - Towing and down ball weights allowable may differ according to model variations. Please refer to owner's manual or vehicle dealer to confirm exact rating for your vehicle model variant.
 - It is not uncommon for the vehicle tow rating to differ from the towbar rating. When this occurs, the lesser rating must be adhered to.
 - For vehicles fitted with enhanced vehicle functions that may be altered/changed when towing i.e Trailer sway mitigation, blind spot detection, adaptive cruise control etc. Please consult owner's manual to understand changes enabled when towing and after towing.

i WARRANTY INFORMATION:

Hayman Reese Towbars are covered by a Lifetime Warranty.

Our goods come with guarantees that cannot be excluded under the Australian Consumer Law. You are entitled to a replacement or refund for a major failure and for compensation for any other reasonably foreseeable loss or damage. You are also entitled to have the goods repaired or replaced if the goods fail to be of acceptable quality and the failure does not amount to a major failure.

For further details please visit www.haymanreese.com.au/warranty or contact customer service on 1800 812 017 or info@haymanreese.com.au.



CUSTOMER INFORMATION

PLACE THESE INSTRUCTIONS IN THE VEHICLE'S GLOVEBOX AFTER INSTALLATION

HAYMAN REESE SMART PIN

Your Hayman Reese towbar is equipped with Smart Pin technology to help reduce towbar tongue rattle in most driving conditions. Please ensure below instructions are understood and routine maintenance is carried out to ensure best towing experience.

i Regularly inspect for wear and check the tightness of the Smart Pin Nut. Follow instructions below to re-tighten the nut as necessary when movement and noise in the tow ball mount is noted.

- Before towing, ensure R-Clip is properly installed and Smart pin nut is installed and tensioned. Replacement parts are available from your Hayman Reese Distributor.

TOWBALL MOUNT REMOVAL/INSTALLATION

STEP 1

Insert Trailer Ball Mount (TBM) (a) into towbar hitchbox (b), aligning hole in TBM shank (c) with hole in hitchbox (d) (Fig. 1)

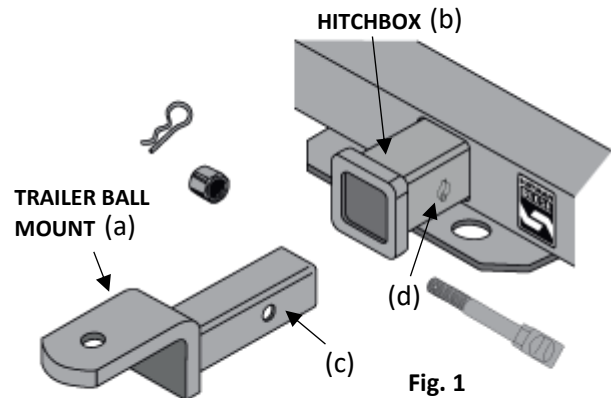

STEP 2

Insert Smart Pin (e) through hole in hitchbox and hole in TBM shank (g); ensure the locators are inserted into the notches in the hitchbox (Fig. 2)

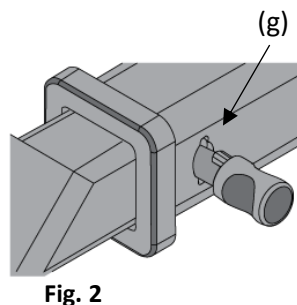

STEP 3

Screw Smart Pin Nut (f) onto Smart Pin (g); tighten Smart Pin Nut until finger tight, ensuring TBM is restrained from up and down movement.

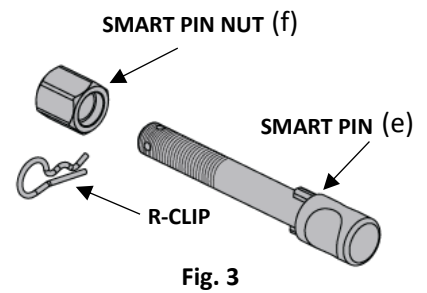

STEP 4

Tighten Smart Pin Nut by turning nut a further 1/8th of a turn in the clockwise direction using a 24mm spanner (Fig. 4).

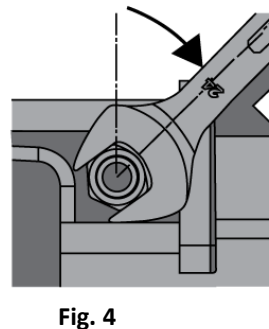

STEP 5

Install Smart Pin R-Clip through the hole that provides best clearance or easiest access. (Fig. 5)

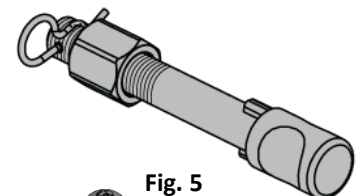

STEP 6

Install towball onto TBM and tighten to **350 Nm** using a calibrated torque wrench (Fig. 6).

