



TOWBAR INSTALLATION INSTRUCTIONS

PART NUMBER 03456RW

TOYOTA LANDCRUISER 78 TROOP CL4



PRODUCT DETAILS:

Part Number:	03456RW	Maximum Towing Braked:	3500	kg
ECU Number:	N/A	Maximum Towing Unbraked:	750	kg
Tail Harness Length Required:	1200 mm	Maximum Static Ball Load:	350	kg
TBM/Lug Part Number:	21325			
Wiring Part Number:	101350-WL			

FITTING DETAILS:

Towbar Installation Time:	60 Mins.	Hayman Reese SmartCODE Solution Required:	NO
Wiring Installation Time:	15 Mins.	RPA Disable/Other:	NO
Total Installation Time:	75 Mins.		
Bumper Cut Required:	No		



TOWBAR INSTALLATION INSTRUCTIONS

PART NUMBER 03456RW

TOYOTA LANDCRUISER 78 TROOP CL4

ENSURE THAT INSTRUCTIONS ARE UNDERSTOOD PRIOR TO FITMENT.

i BEFORE YOU START:

Hayman Reese recommends that instructions are read completely prior to fitment. Check all hardware items have been included refer to assembly diagram. Please ensure this towbar is only fitted to vehicle models as per Hayman Reese application guide (www.haymanreese.com.au).

Bumper Cuts



Vehicle and bumper variations can and do occur during vehicle manufacture after initial towbar design. Fitment of towbar to vehicle and accuracy of bumper cut must be assessed prior to any bumper modifications made. Incorrect bumper cuts are not covered under Hayman Reese warranty.

NOTE: Bumper cuts need to be approached with care, refer to notes below.

- Bumper centreline – where the centreline of the bumper needs to be determined, the installer must assess centre point by measurement of bumper width or determining two symmetrical reference points to give centreline.
- Bumper edge – To assist with accurate bumper cut measurement, reference to the start of the bumper edge is now being commonly used.
 - Measure from bottom edge along bumper and around corner to the 70 mm point (Figure 1).
 - Do not measure from visible bumper front of corner, upwards (Figure 2).

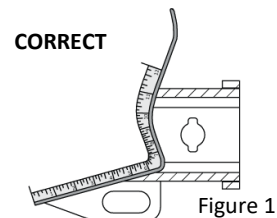

Figure 1

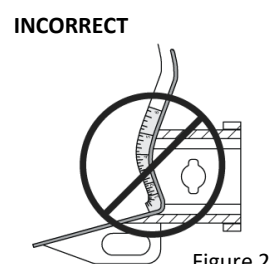

Figure 2

Drilling

- For any required drilling during installation, ensure that the area is clear of fuel, electrical & other components that may be damaged.
- All holes drilled into the body panels shall have all burrs & swarf removed then coated with a suitable rust preventative paint.

Bolts/Fasteners

- Ensure that all hardware is fastened to correct torque as specified in this fitting instruction.
- All fasteners supplied with this product are used to achieve a specified clamp loading. If replacement is required ensure that fasteners of the same grade and class are used.



NOTE: Achieving correct torque is critical to proper installation and responsibility of the installer. Towbar failures attributed to tension issues from over tightening or under tightening are not covered by Hayman Reese warranty.

Product Labels

- a. Towbar load rating sticker provided with this product shall be conspicuously located on inside rear end of the driver's door.
- b. Powertrain Control Module (PCM)/Body Control Module (BCM) upgrade warning label will be provided in towbar kit for vehicles as required. Affix warning label in door and owner's handbook.

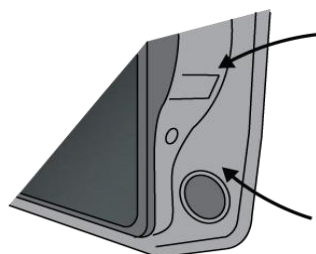

Place **Load Rating sticker** inside driver's door here

Place **Vehicle PCM/ BCM upgrade warning label** in door AND on front cover of owner's service handbook

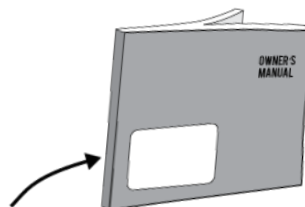

WARNING:

Do not, drill, cut, weld or otherwise modify the towbar.

FOR TOWING PURPOSES ONLY - This towbar is designed and tested by Hayman Reese to adhere to ADR 62/02 which provides only for the expected load demands of towing.



TOWBAR INSTALLATION INSTRUCTIONS

PART NUMBER 03456RW

TOYOTA LANDCRUISER 78 TROOP CL4

i TOWBAR ASSEMBLY DIAGRAM

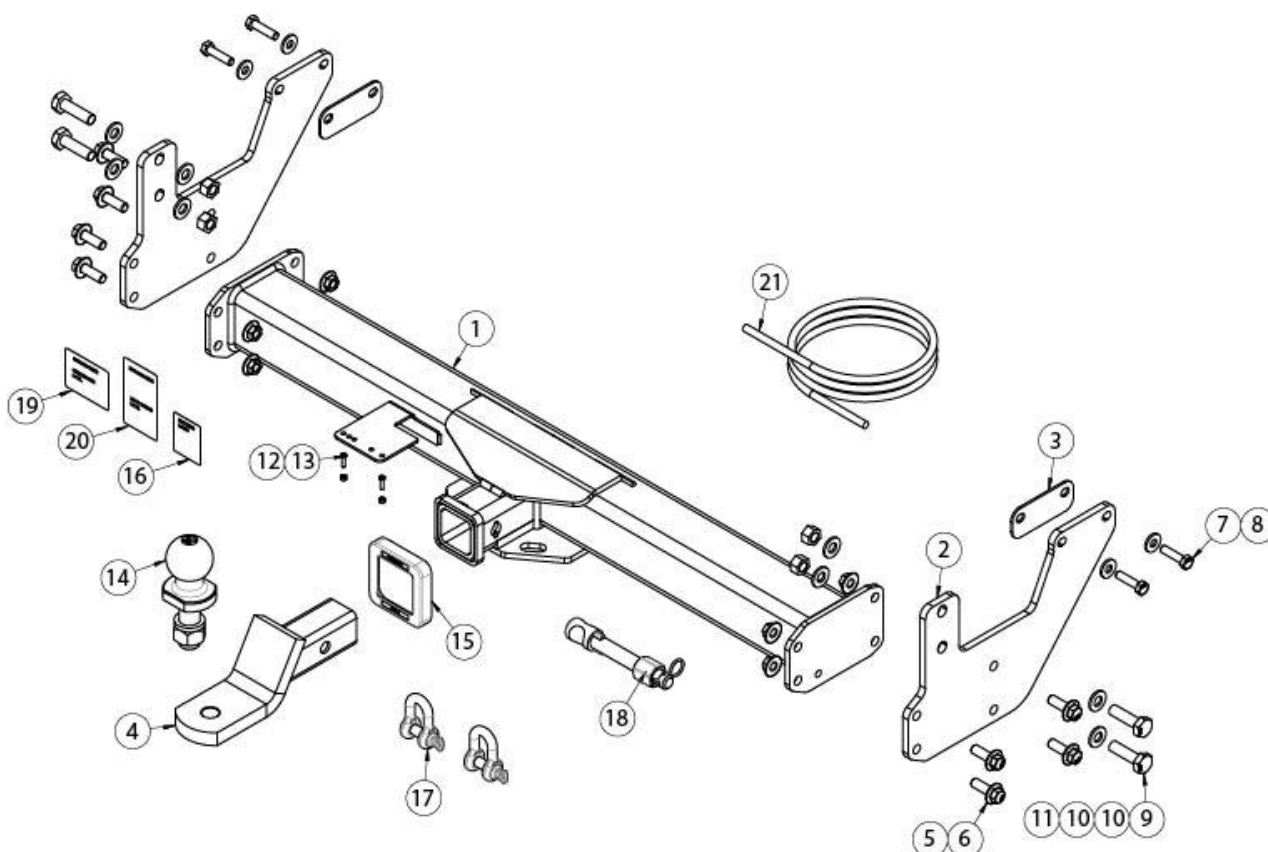

ITEM	DESCRIPTION	QTY
1	TOYOTA LC 78 TROOP ASSY	1
2	SIDE ARM	2
3	SIDE ARM SPACER	2
4	TRAILER BALL MOUNT	1
5	FLANGED NUT HEX HD M12x1.25P	8
6	FLANGED SET SCREW HEX HD M12x35x1.25P	8
7	BOLT HEX HD M10x40x1.25P	4
8	WASHER PLAIN M10x25x3	4
9	SET SCREW HEX HD M14x50x1.5P	4
10	WASHER PLAIN M14x28x3	8
11	NUT HEX HD M14x1.5P	4

ITEM	DESCRIPTION	QTY
12	NUT NYLOC HEX HD M4x0.7P	2
13	SCREW PAN HD M4x16x0.7P	2
14	TOWBALL 50mm	1
15	HITCH BOX COLLAR COVER	1
16	HAYMAN REESE LOGO STICKER	1
17	"D" SHACKLE 10mm	2
18	SMART PIN GOLD	1
19	COMPLIANCE LABEL	1
20	LOAD RATING LABEL	1
21	WIRING LOOM	1

1. From under the bumper, remove 3 x nuts (on coach bolt), along with 4 x bolts and remove the light bracket assembly. Ensure to disconnect the wiring loom.

Repeat for other side.

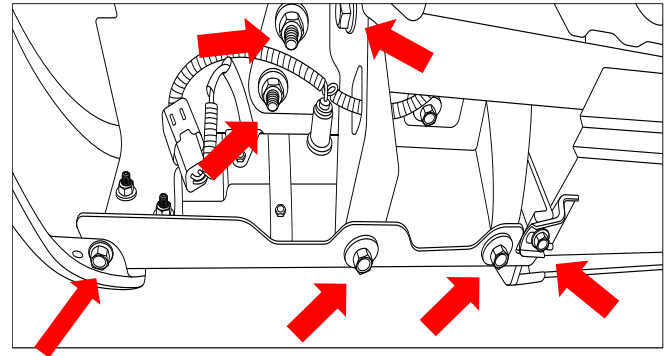

2. Use a marker and outline the current installed position on the bumper bracket to assist with final installation positioning.

Repeat for the other side.

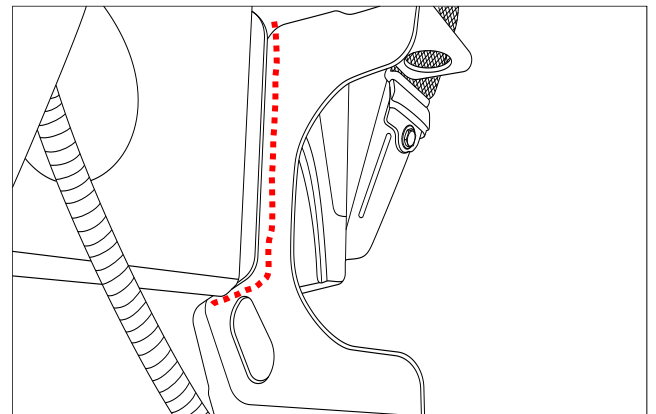

3. On the bumper bracket, mark off the bolts centre position for the top and bottom bolts.
4. Remove the bumper bracket secure with 3 x bolts.

Repeat for other side.

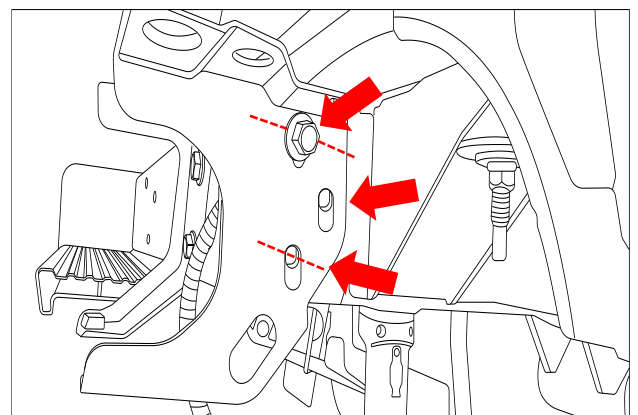

5. Open up the marked position on the bumper bracket top and bottom holes to suit a M14 bolt.
6. On chassis, drill out the top and bottom mounting holes to $\text{Ø}14.5\text{mm}$.
7. Use a cold chisel and hammer to remove the top and bottom weld nuts located inside of the chassis rail.
8. Coat the bare material with a suitable rust protector.

Repeat steps for other side.

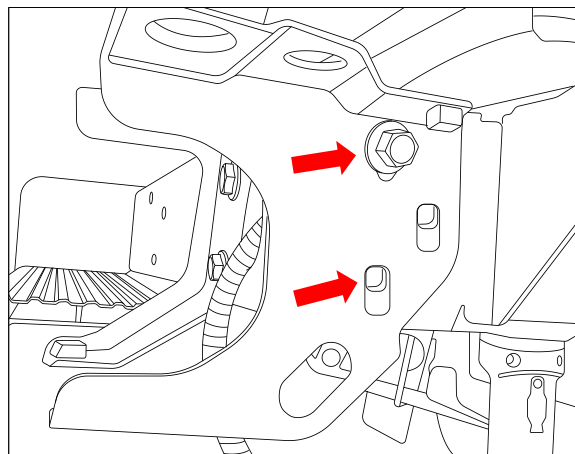

9. Lift the towbar side arm up to the chassis rail along with the 3mm spacer and loosely secure the forward hole positions with 2 x M10 bolts complete with 1 x washer per bolt.
10. With the bumper bracket positioned between the chassis rail and the side arm bracket, loosely secure the rear hole positions with 2 x M14 bolts complete with 2 x washers and 1 x nut per bolt.

Repeat for the other side.

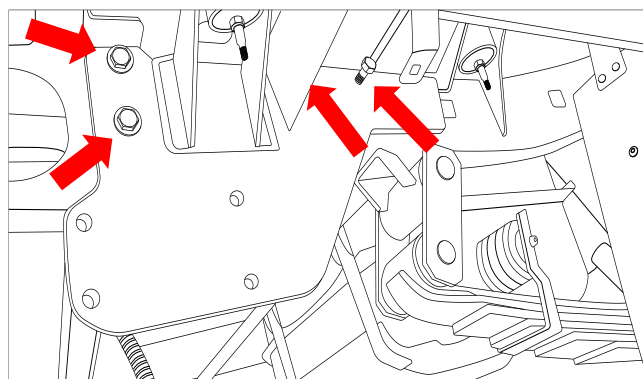

11. Lift the crosstube assembly up to the side arms and loosely secure each side with 4 x M12 flanged head bolts complete with 1 x flanged nut per bolt.
12. Tighten all fasteners to the following torque.

M10 x 1.25 Gr10.9 : 68Nm

M12 x 1.25 Gr10.9 : 165Nm

M14 x 1.5 Gr10.9 : 196Nm

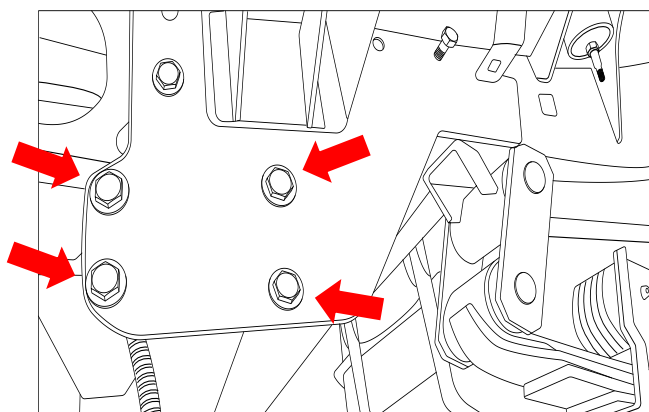



TOWBAR INSTALLATION INSTRUCTIONS

PART NUMBER 03456RW

TOYOTA LANDCRUISER 78 TROOP CL4

13. Locate 8-way pre-wire connector on the LHS chassis rail.
14. Remove the blanking plug and discard.

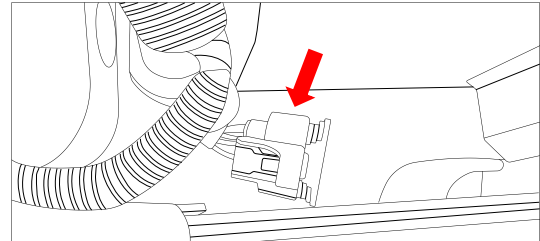

15. Connect the trailer harness 101350-WL to the trailer pre-wire connector.
16. Mount the trailer plug to plug bracket, route tail harness towards the trailer patch mating blue connector; connect **and waterproof using electric grease**.
17. Secure the harness and relays to vehicle main loom.
18. Test trailer function using trailer test board
19. Refit all removed parts.
20. Place instructions in glovebox.

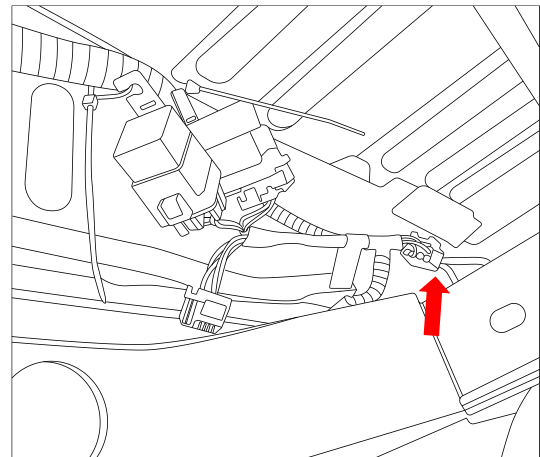



CUSTOMER INFORMATION

PLACE THESE INSTRUCTIONS IN THE
VEHICLE'S GLOVEBOX AFTER INSTALLATION

**THANK YOU FOR PURCHASING HAYMAN REESE.
WITH CORRECT MAINTENANCE AND CARE THIS PRODUCT WILL PROVIDE A
LIFETIME OF TROUBLE-FREE OPERATION.**

i TOWBAR MAINTENANCE AND CARE:

1. Hayman Reese recommend that the towbar LUG or TBM (tow ball Mount) Pull Pin and R-clip are removed and stored when not in use. Removal of LUG or TBM (tow ball mount) is advisable when not in use to assist with any of the following.
 - Ensure rear number plate is not obscured.
 - Allow maximum available departure angle and prevent any potential interference.
 - Prevent possible interference with vehicles reverse sensors or camera detecting a tow ball mount as an obstruction during reversing.
 - Removes towball mount as an obstruction for when moving around the rear of the vehicle.
2. Hayman Reese recommends routine inspection of your towbar to ensure trouble free towing.
 - Bolt security and tension should be regularly inspected and checked for correct tension. Replace any worn or defective parts with suitable grade & class fasteners. Inspection should be requested to coincide with vehicle major services.
3. It is the owner's responsibility to ensure towing and down ball weight capacities of the towing vehicle are not exceeded.
 - Towing and down ball weights allowable may differ according to model variations. Please refer to owner's manual or vehicle dealer to confirm exact rating for your vehicle model variant.
 - It is not uncommon for the vehicle tow rating to differ from the towbar rating. When this occurs, the lesser rating must be adhered to.
 - For vehicles fitted with enhanced vehicle functions that may be altered/changed when towing i.e Trailer sway mitigation, blind spot detection, adaptive cruise control etc. Please consult owner's manual to understand changes enabled when towing and after towing.

i WARRANTY INFORMATION:

Hayman Reese Towbars are covered by a Lifetime Warranty.

Our goods come with guarantees that cannot be excluded under the Australian Consumer Law. You are entitled to a replacement or refund for a major failure and for compensation for any other reasonably foreseeable loss or damage. You are also entitled to have the goods repaired or replaced if the goods fail to be of acceptable quality and the failure does not amount to a major failure.

For further details please visit www.haymanreese.com.au/warranty or contact customer service on 1800 812 017 or info@haymanreese.com.au.



CUSTOMER INFORMATION

PLACE THESE INSTRUCTIONS IN THE VEHICLE'S GLOVEBOX AFTER INSTALLATION

HAYMAN REESE SMART PIN

Your Hayman Reese towbar is equipped with Smart Pin technology to help reduce towbar tongue rattle in most driving conditions. Please ensure below instructions are understood and routine maintenance is carried out to ensure best towing experience.

i Regularly inspect for wear and check the tightness of the Smart Pin Nut. Follow instructions below to re-tighten the nut as necessary when movement and noise in the tow ball mount is noted.

- Before towing, ensure R-Clip is properly installed and Smart pin nut is installed and tensioned. Replacement parts are available from your Hayman Reese Distributor.

TOWBALL MOUNT REMOVAL/INSTALLATION

STEP 1

Insert Trailer Ball Mount (TBM) (a) into towbar hitchbox (b), aligning hole in TBM shank (c) with hole in hitchbox (d) (Fig. 1)

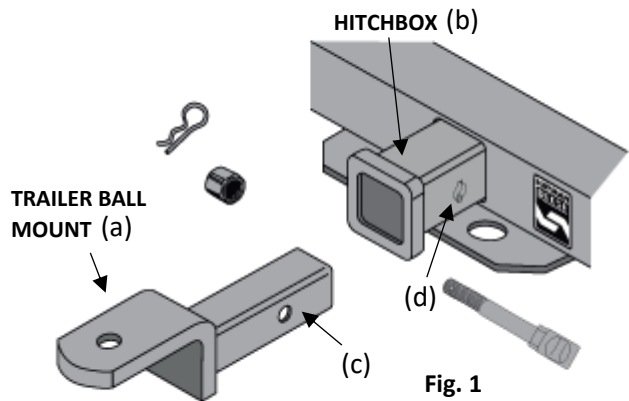

STEP 2

Insert Smart Pin (e) through hole in hitchbox and hole in TBM shank (g); ensure the locators are inserted into the notches in the hitchbox (Fig. 2)

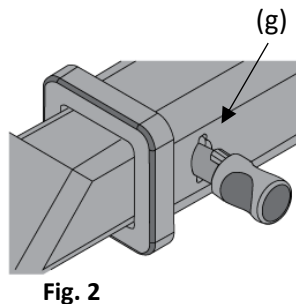

STEP 3

Screw Smart Pin Nut (f) onto Smart Pin (g); tighten Smart Pin Nut until finger tight, ensuring TBM is restrained from up and down movement.

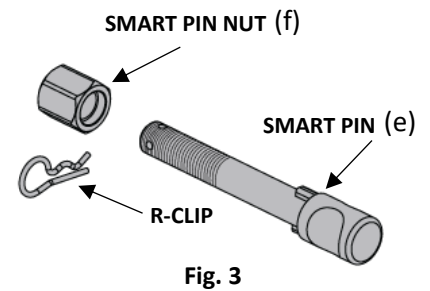

STEP 4

Tighten Smart Pin Nut by turning nut a further 1/8th of a turn in the clockwise direction using a 24mm spanner (Fig. 4).

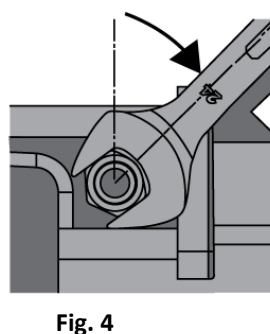

STEP 5

Install Smart Pin R-Clip through the hole that provides best clearance or easiest access. (Fig. 5)

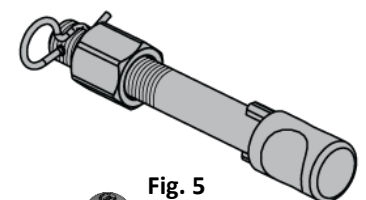

STEP 6

Install towball onto TBM and tighten to **350 Nm** using a calibrated torque wrench (Fig. 6).

