

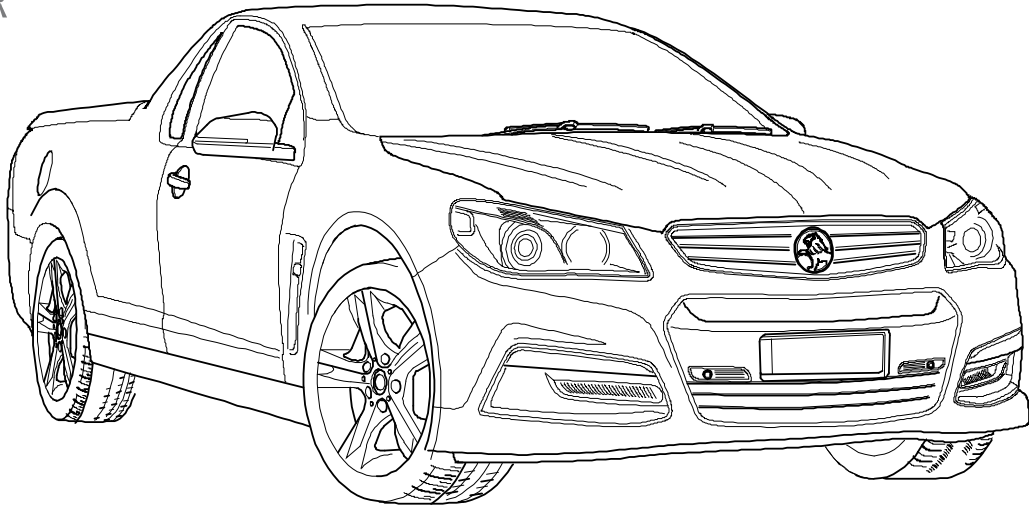

ERICH JAEGER

# Installation instructions



## 750042

### HOLDEN VF UTE

07/13 >>

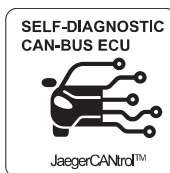
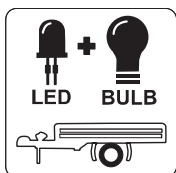
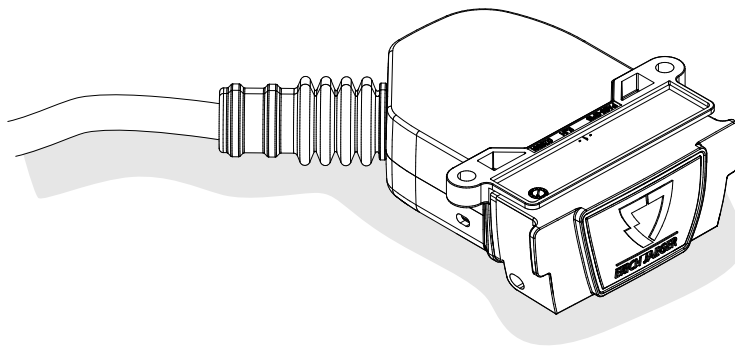

### Reference:

The following information must be reviewed before beginning the assembly:

The installation instructions are to be thoroughly read.

The installation should be carried out by qualified personnel with the relevant technical knowledge.

The vehicle manufacturers' current technical notices and information on retrofitting must be followed.

The removal and replacement instructions found in the current repair manuals must be followed.

It must be ensured that the vehicle is technically suitable for the installation of a trailer hitch.

# OVERVIEW

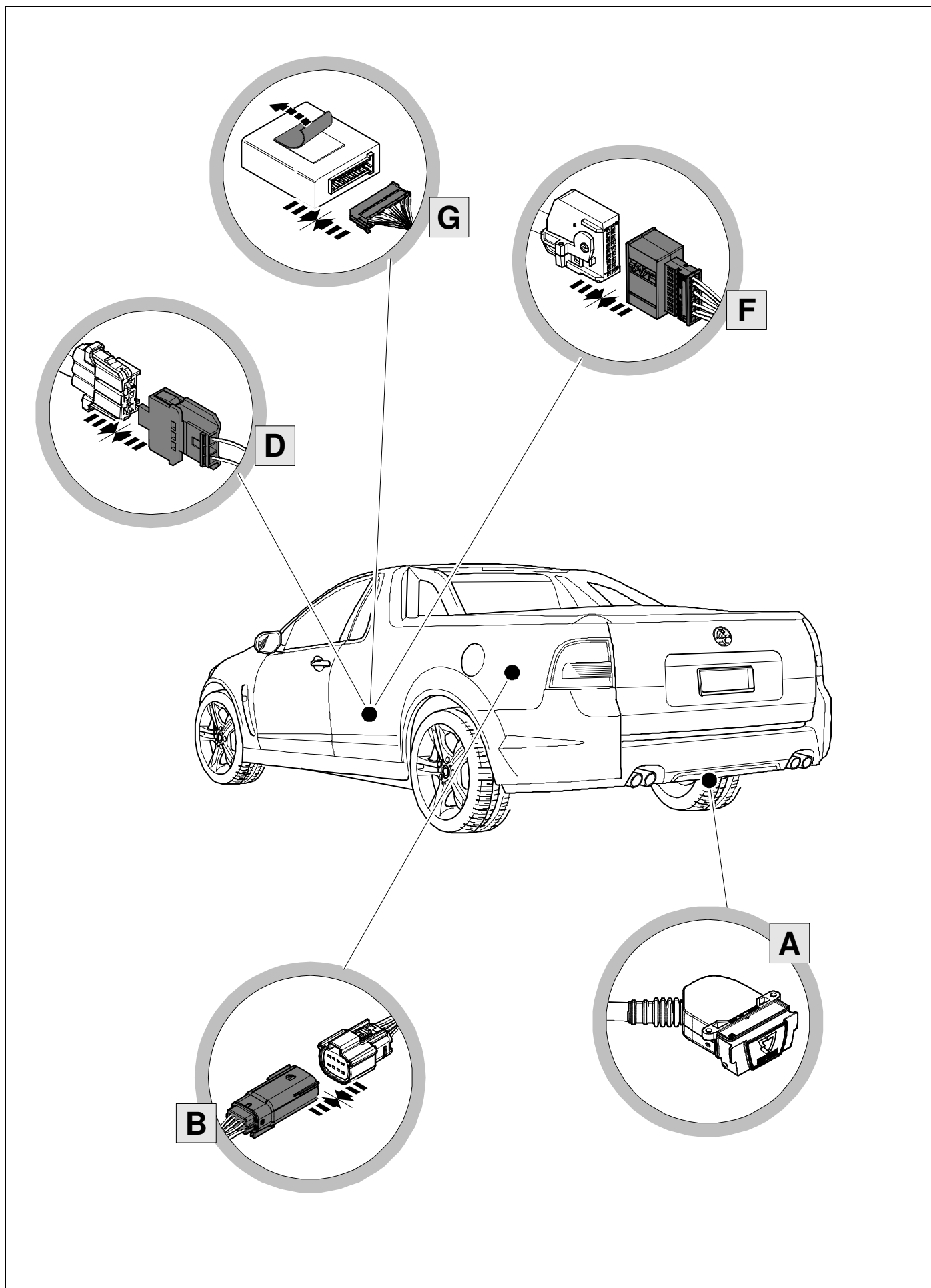

# KIT

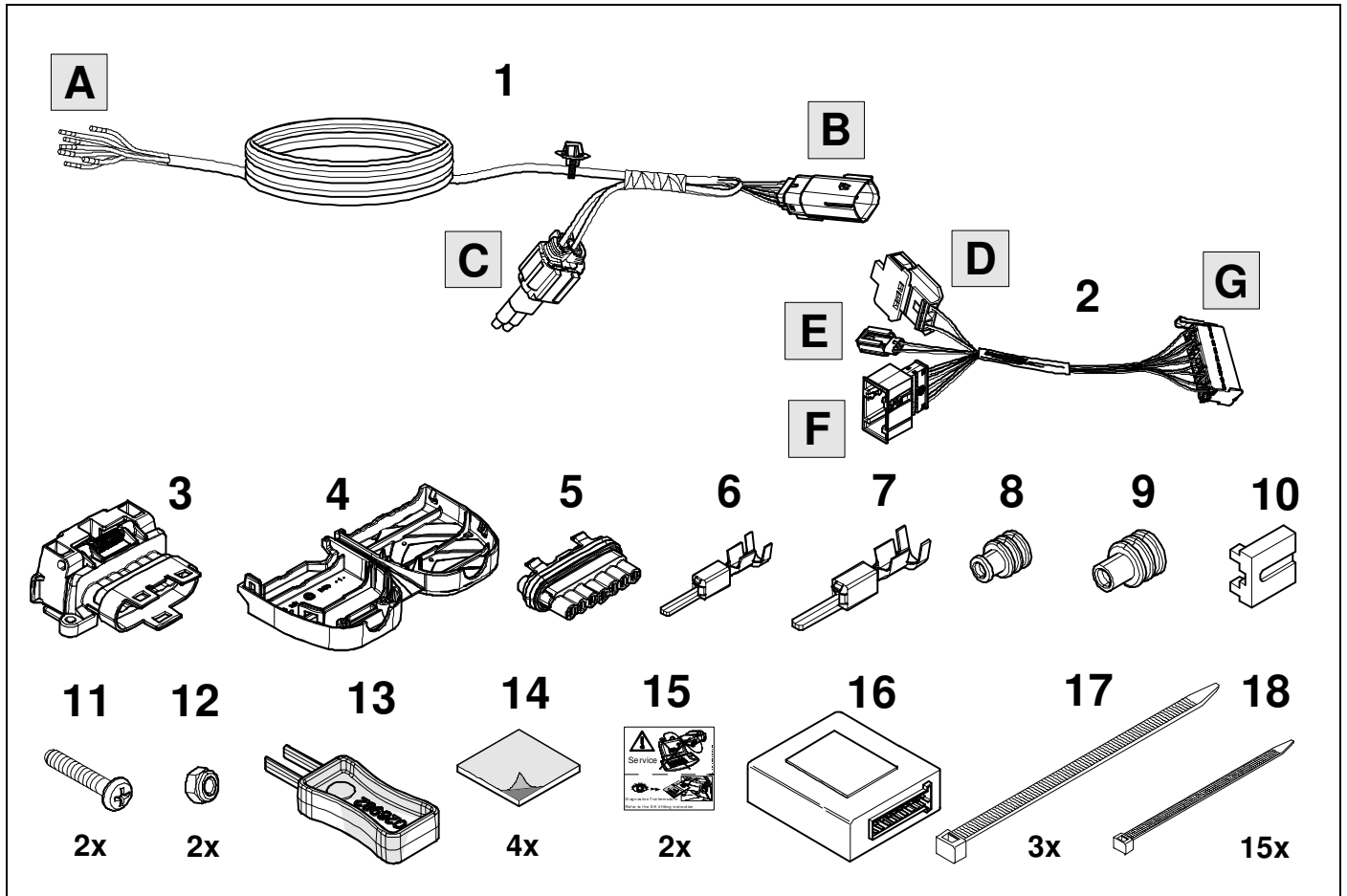

# TOOLS

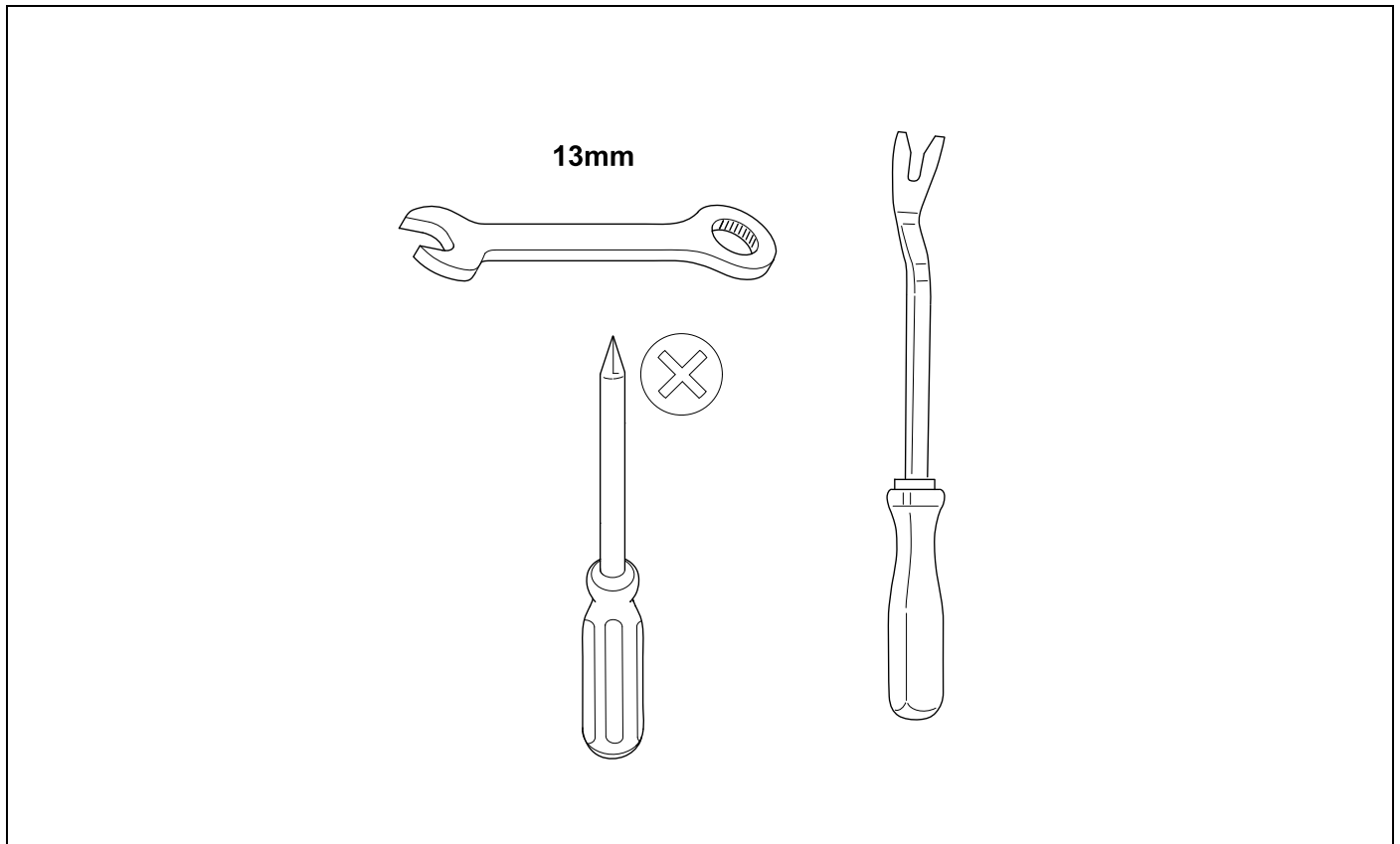

1

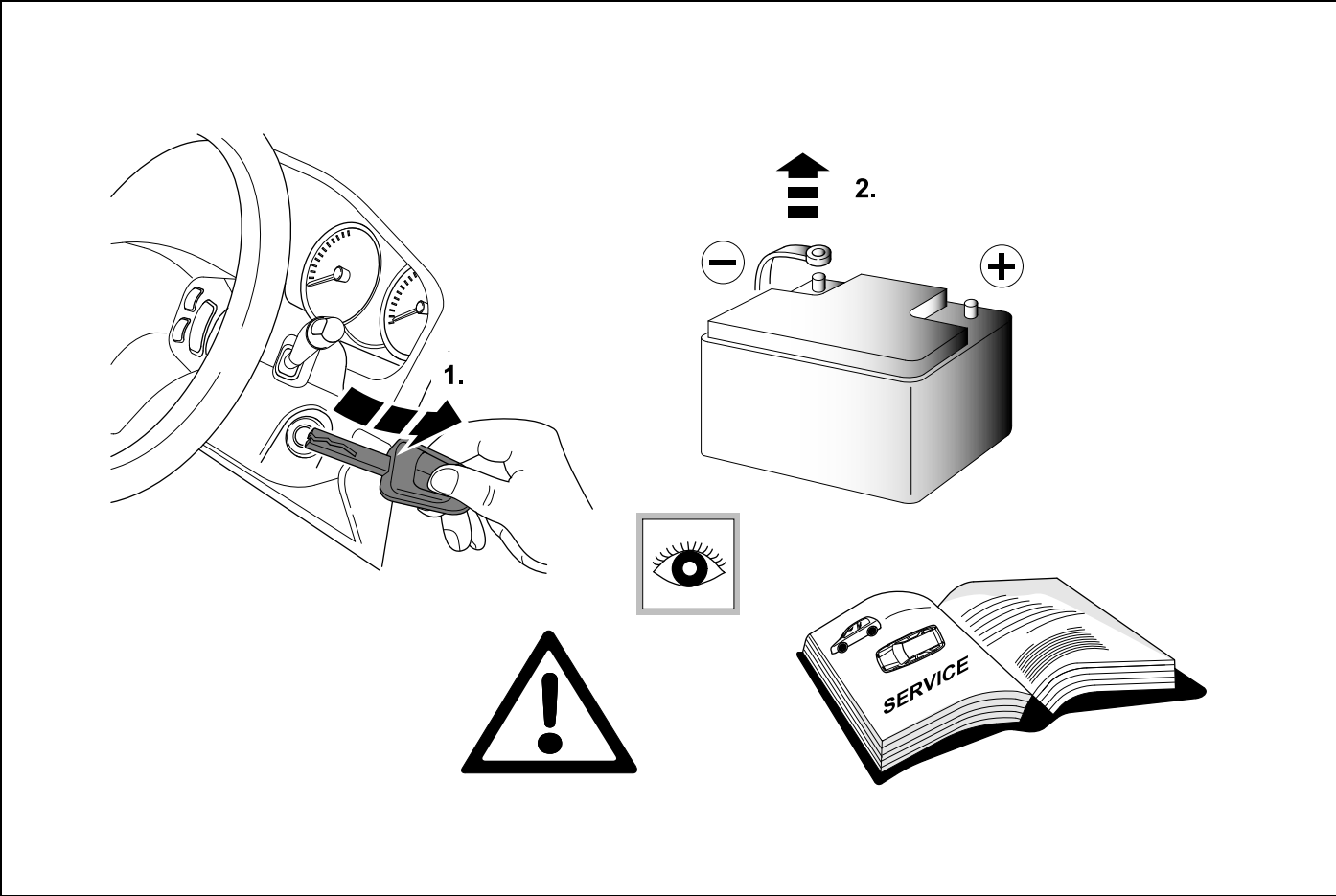

2

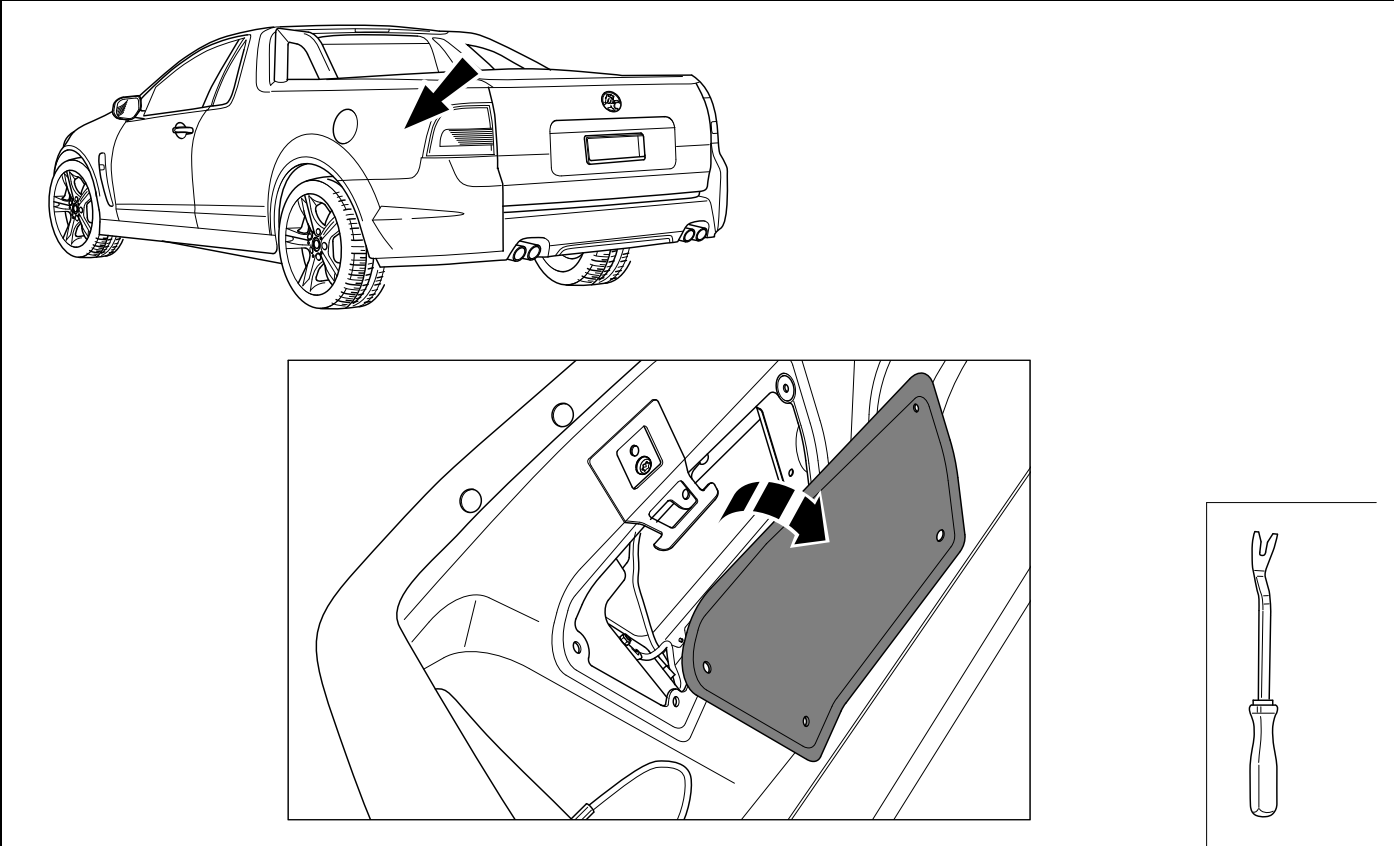

3

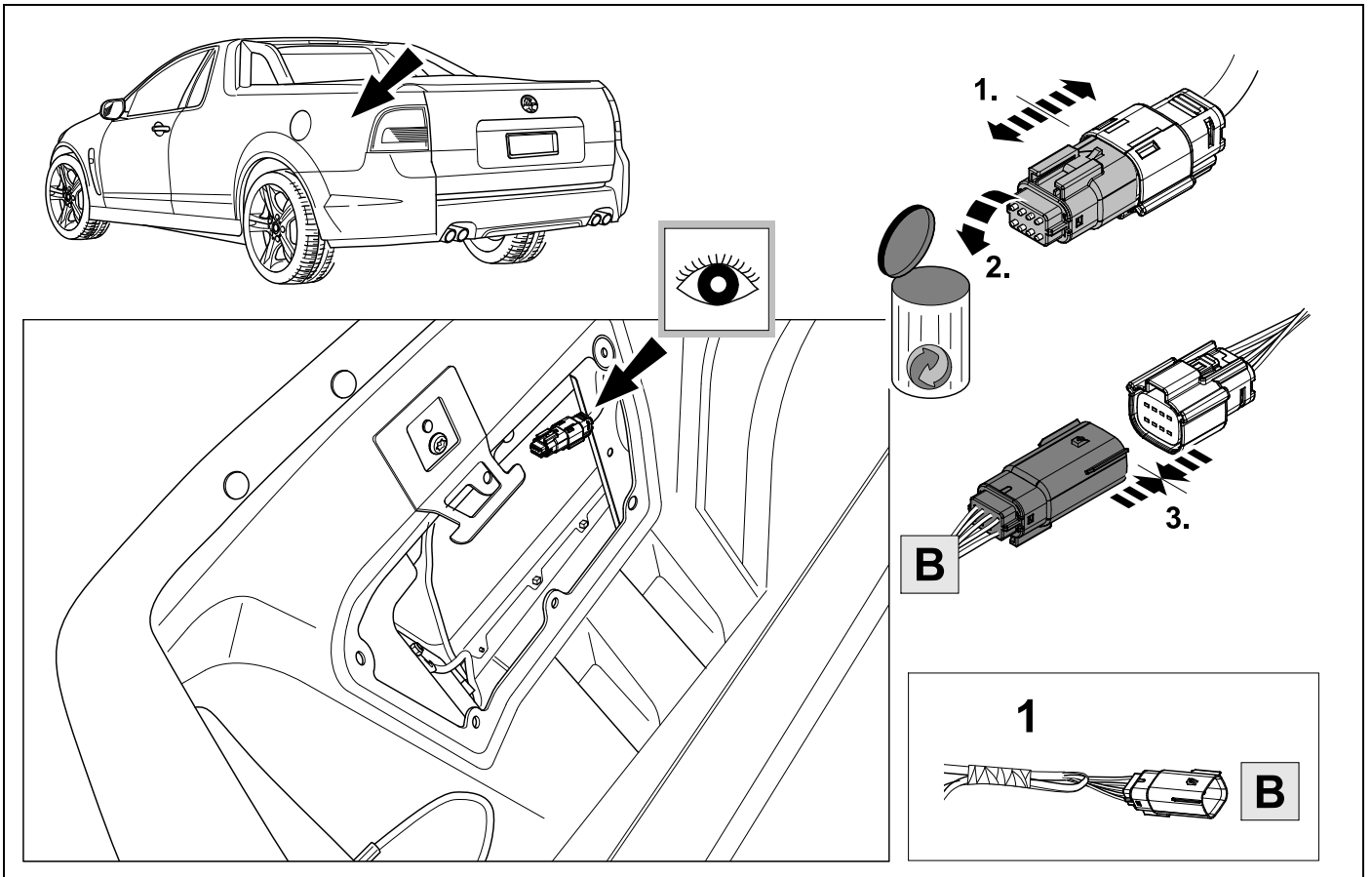

4

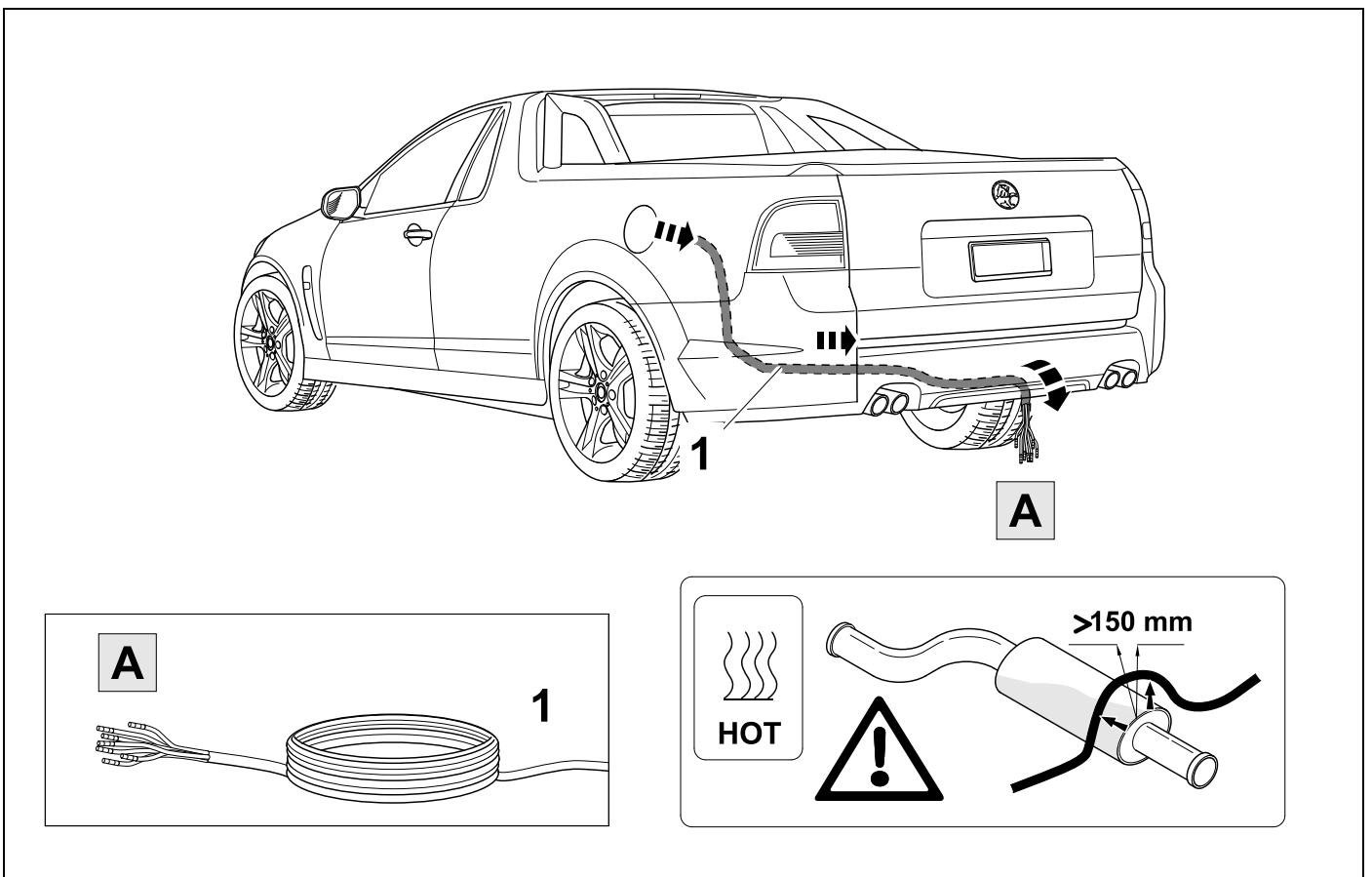

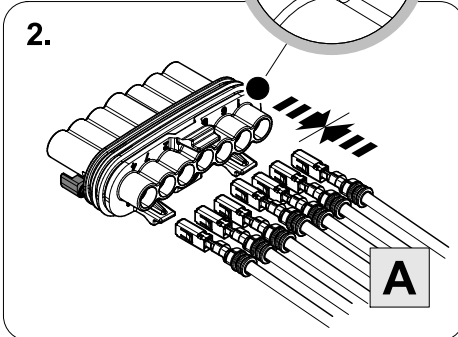
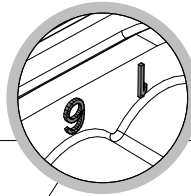
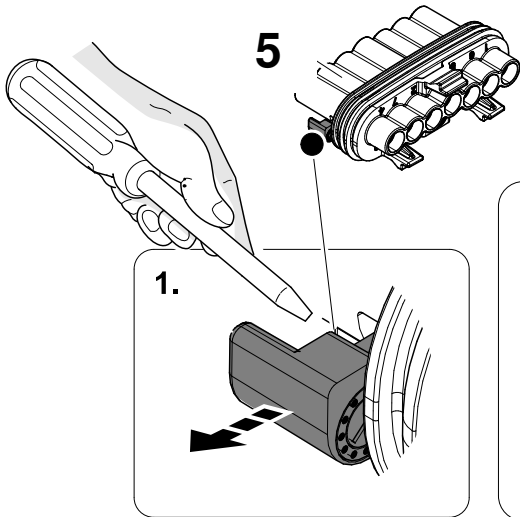

ye	1	
rd	6	
bu	5	
wh	3	
bk	2	
bn	7	
gn	4	

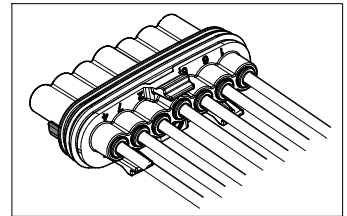
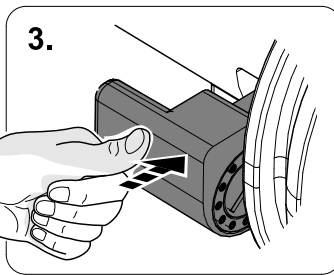
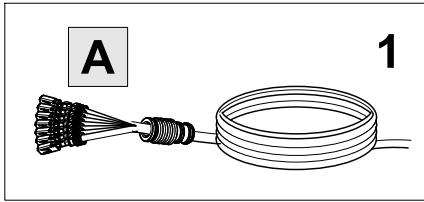

**In case of wrong pin insert:**

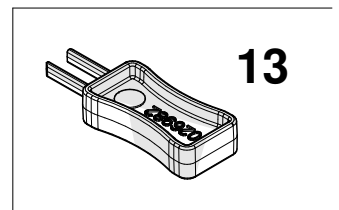
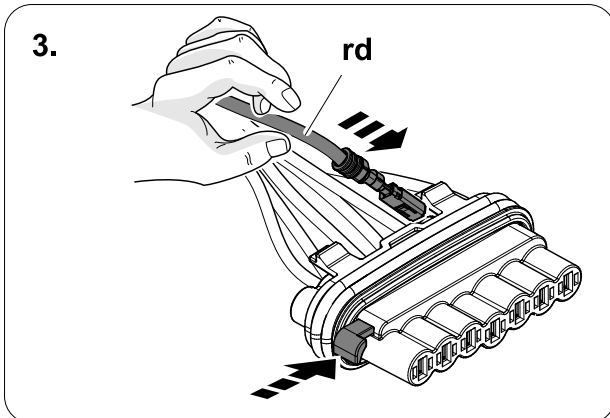
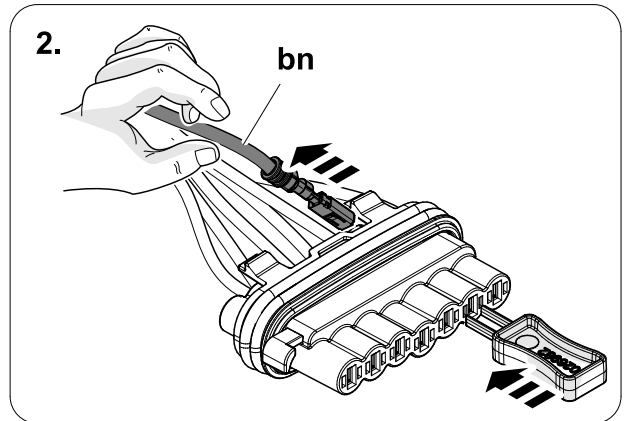
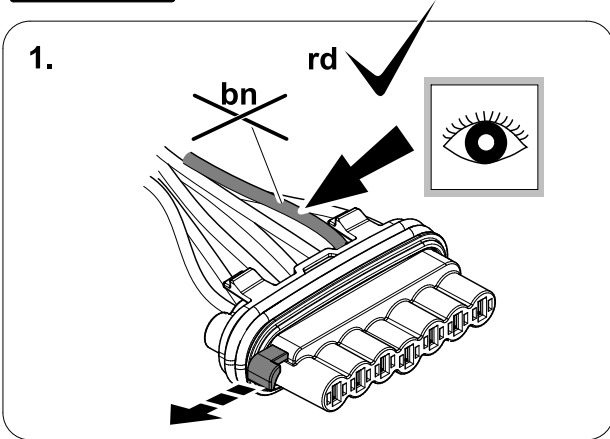

6



8

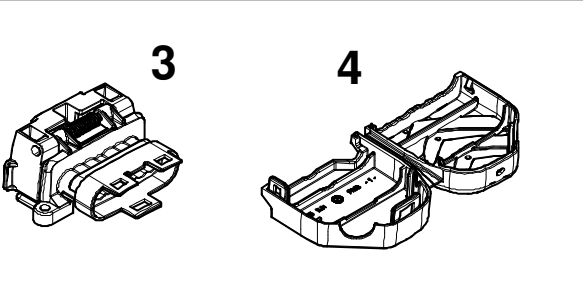
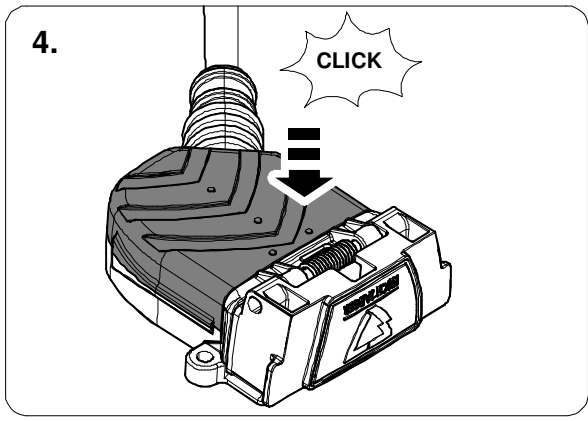
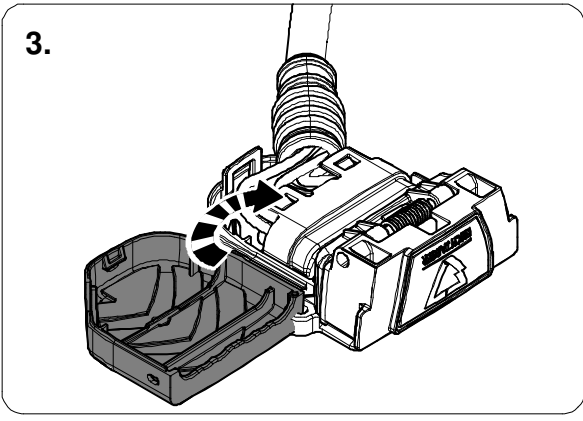
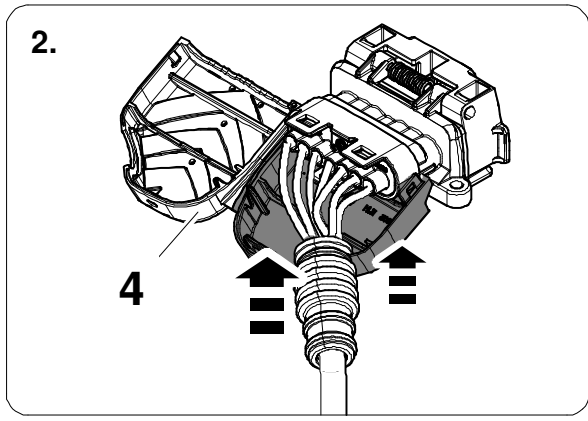
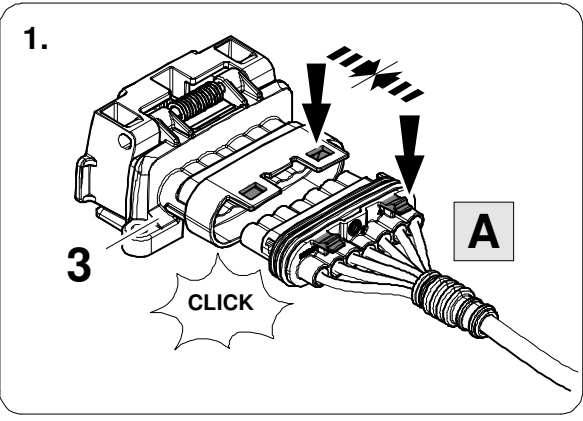

7

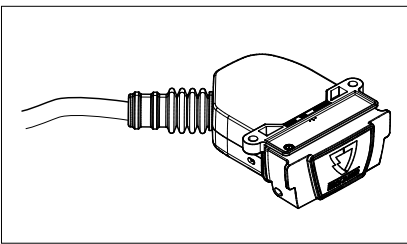
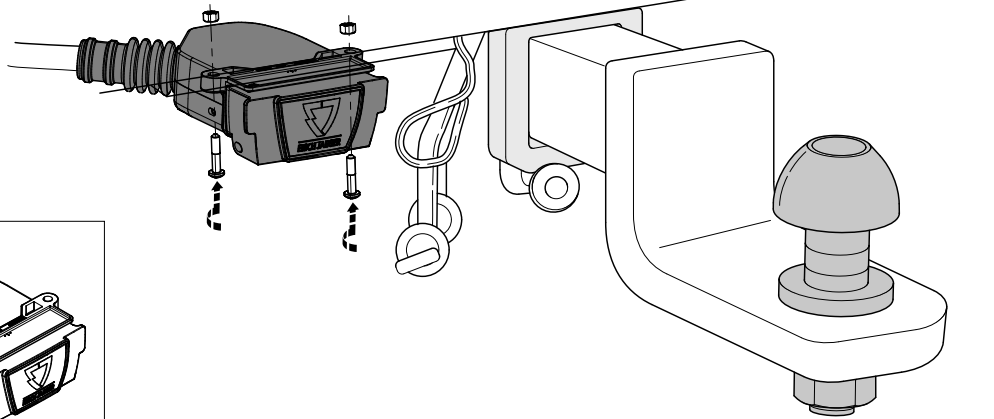

**8****9**

<b>1</b>	<b>ye</b>	
<b>2</b>	<b>bk</b>	
<b>3</b>	<b>wh</b>	
<b>4</b>	<b>gn</b>	
<b>5</b>	<b>bu</b>	
<b>6</b>	<b>rd</b>	
<b>7</b>	<b>bn</b>	

<b>9</b>	<b>bk</b>	<b>wh</b>	<b>gy</b>	<b>gn</b>	<b>rd</b>	<b>bu</b>	<b>ye</b>	<b>bn</b>	<b>pu</b>	<b>or</b>	<b>no</b>
	black	white	grey	green	red	blue	yellow	brown	purple	orange	not occupied

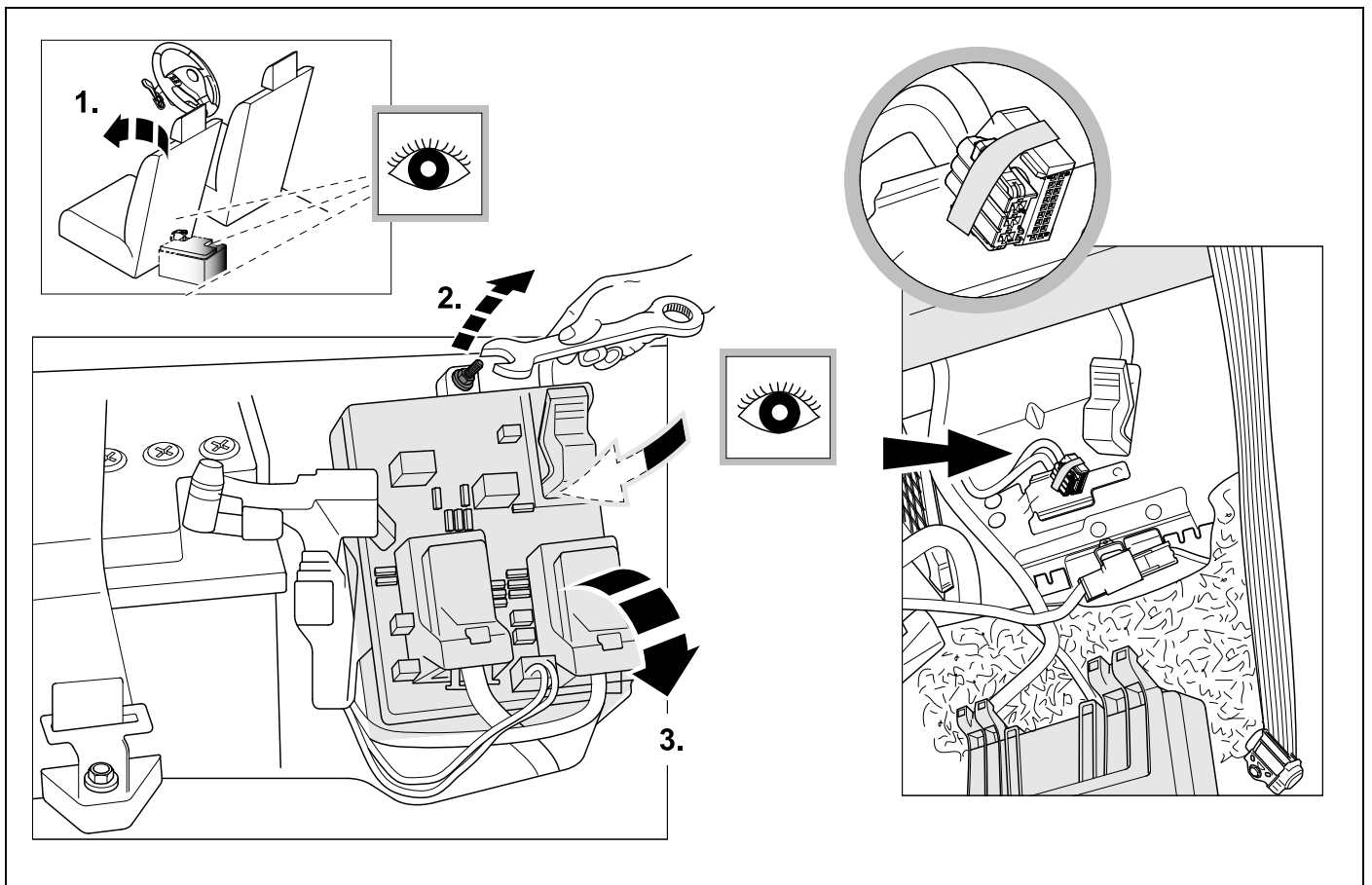
**10**



11

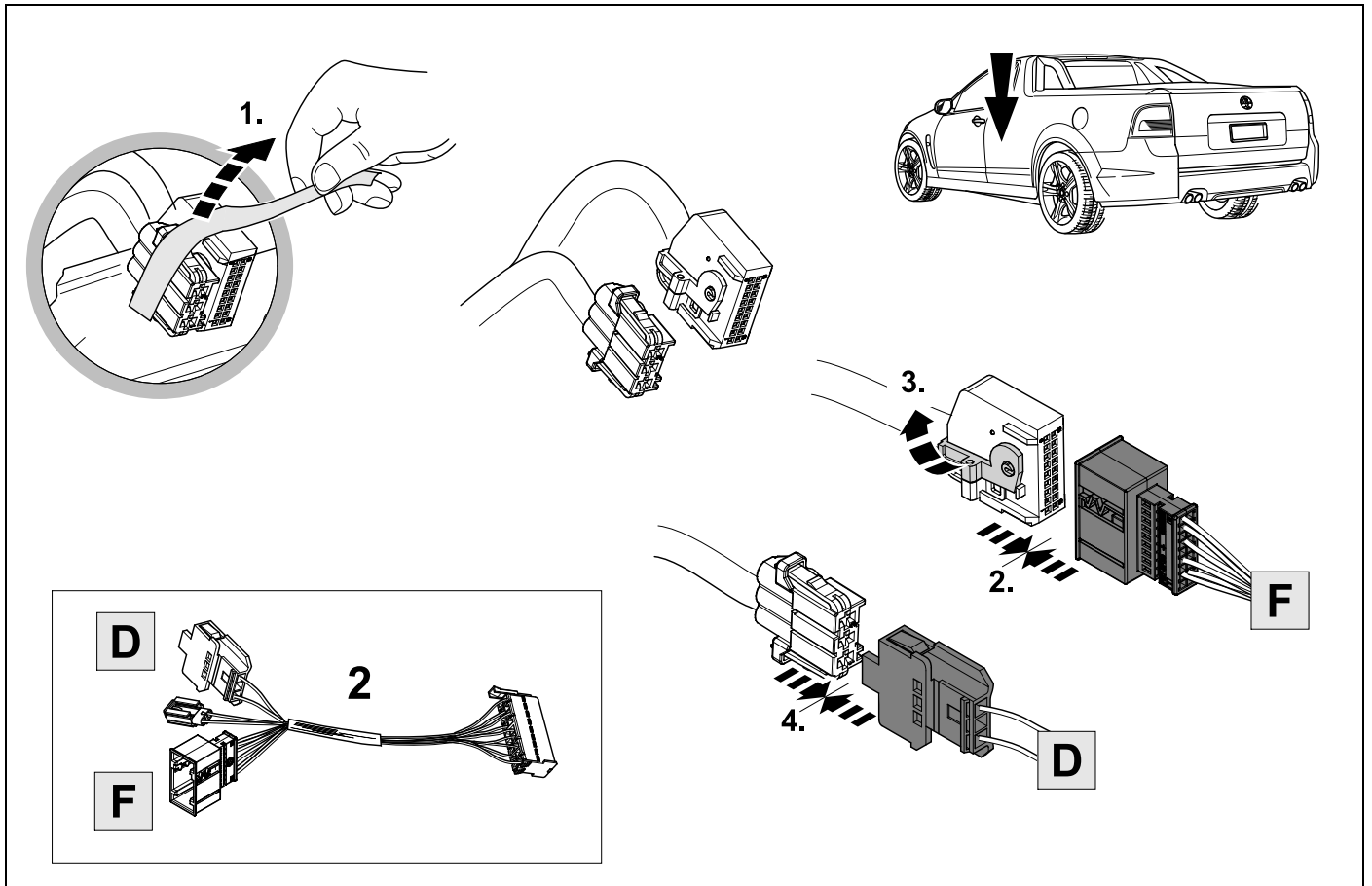

12

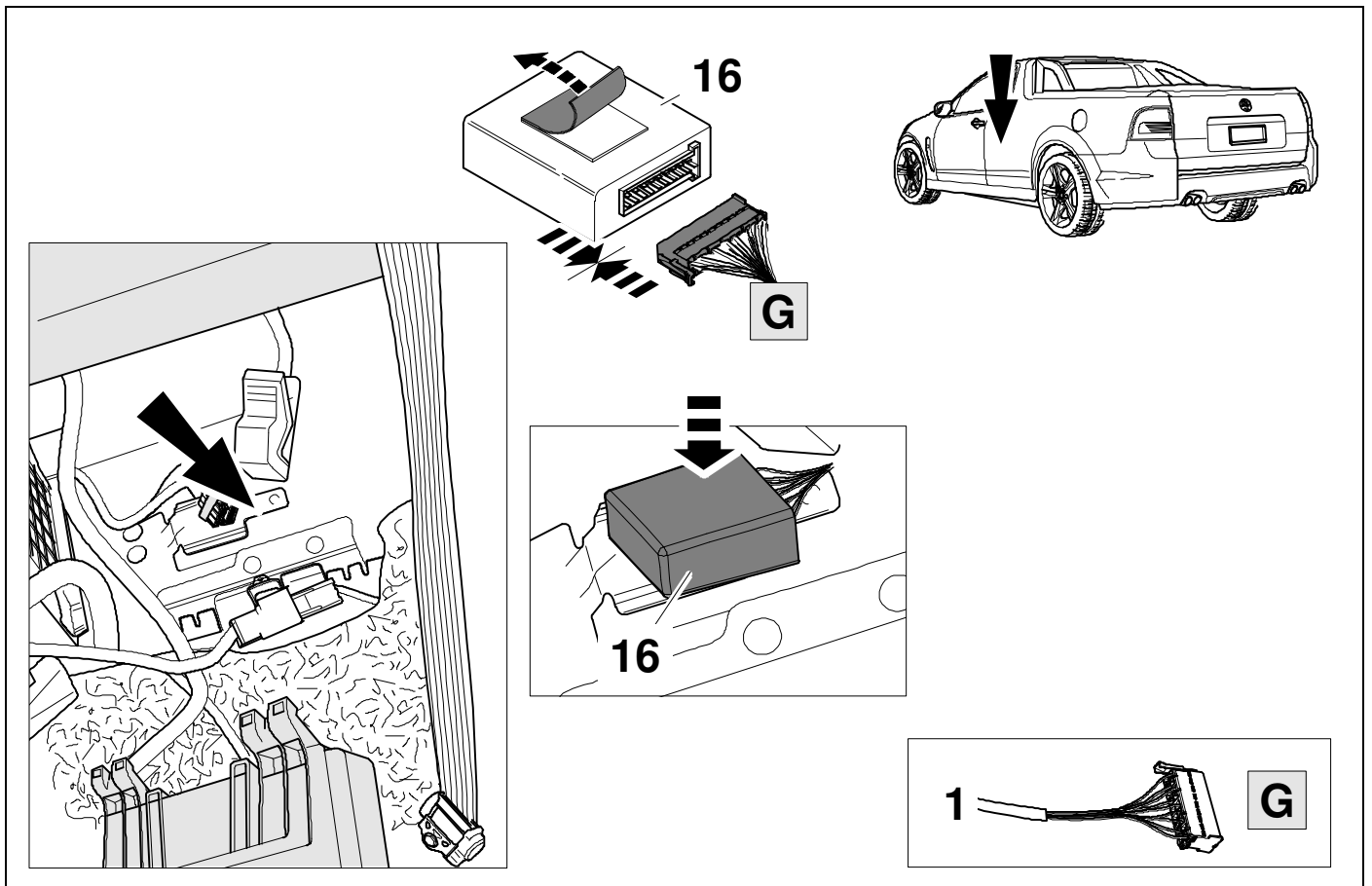

# Trailer Brake Preparation

**BRAKE  
CONTROLLER  
PREPARED**

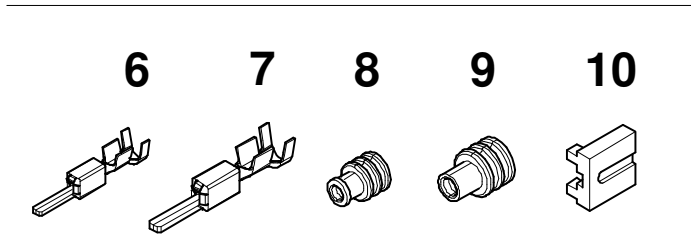
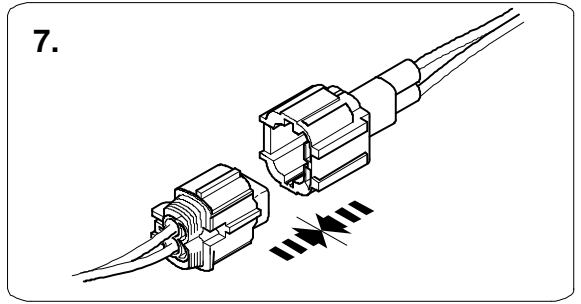
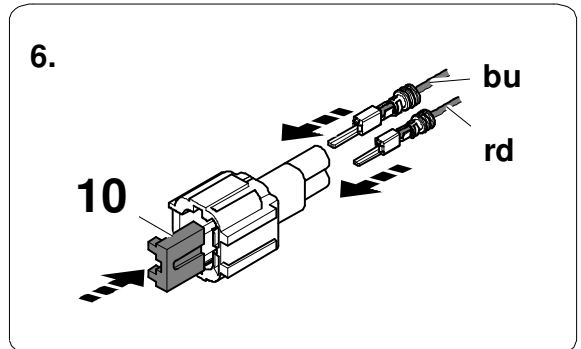
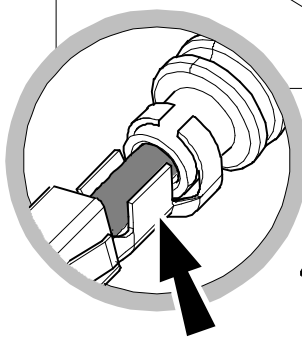
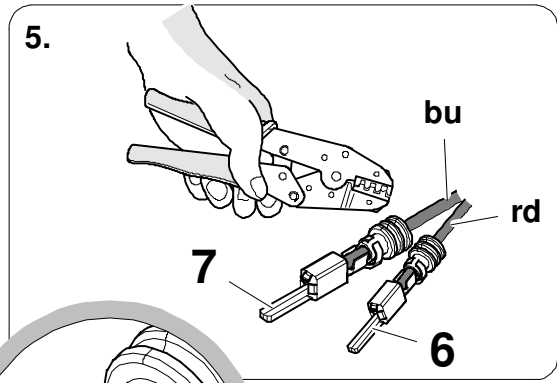
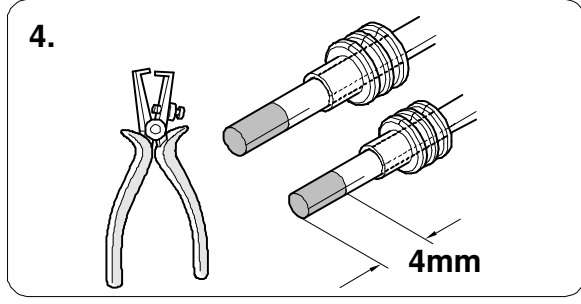
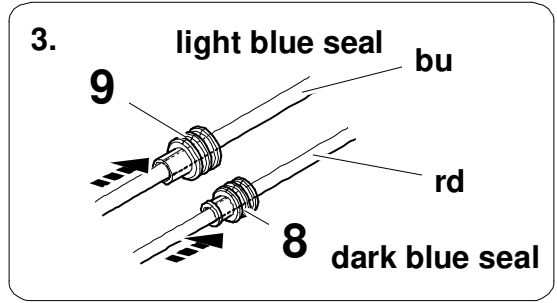
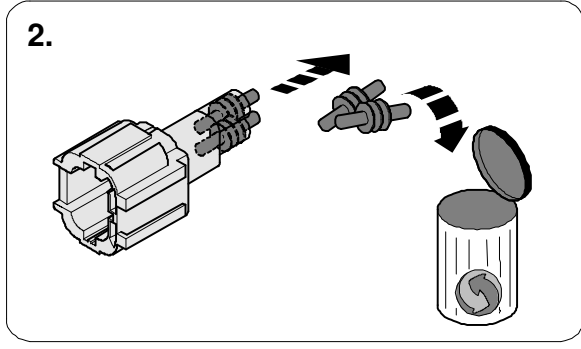
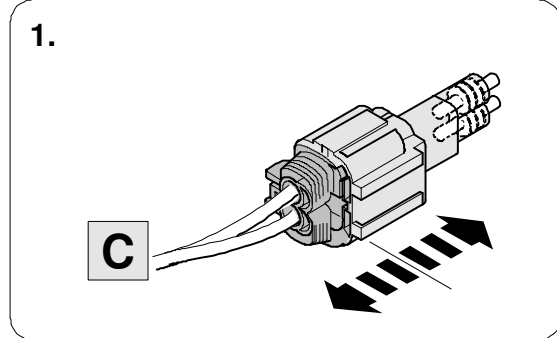

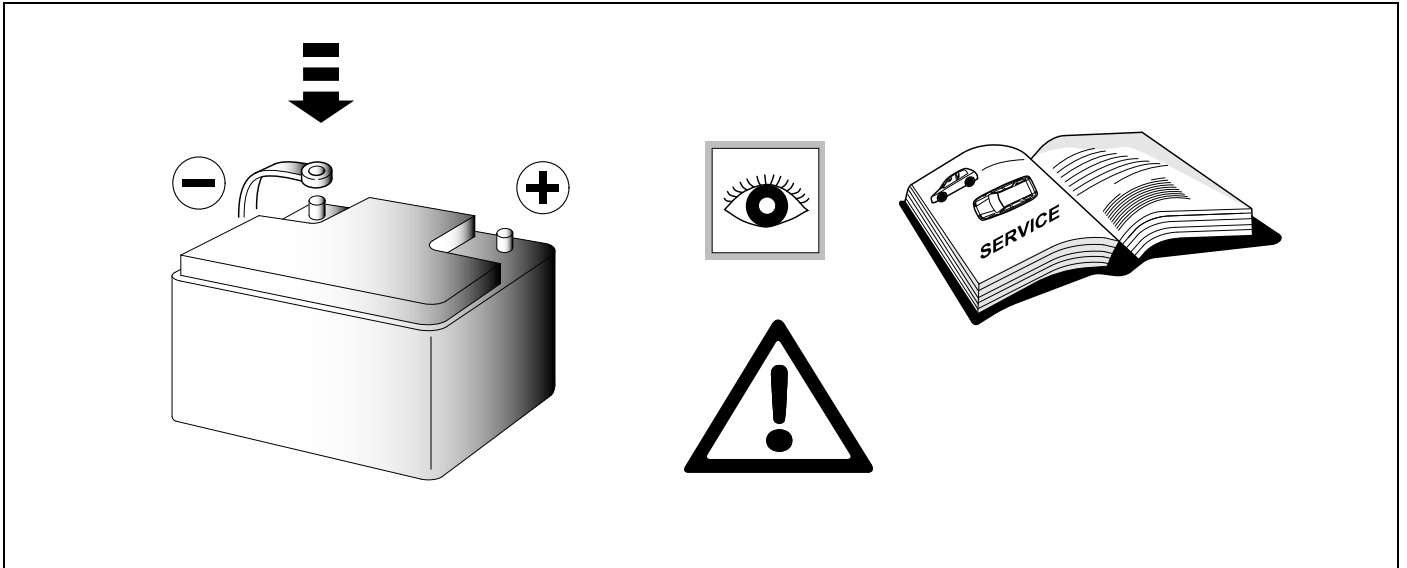

14

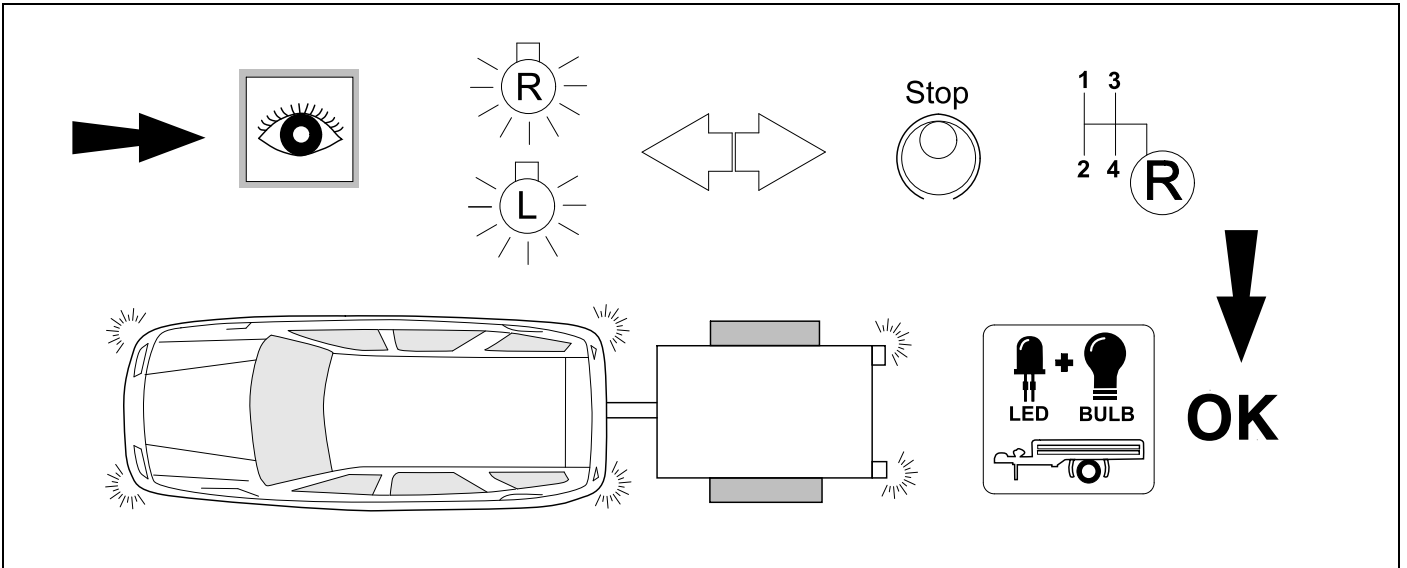

15

### CHECK ALL LIGHTING FUNCTIONS



16

**Bulb out condition indicated with sound from modul speaker**

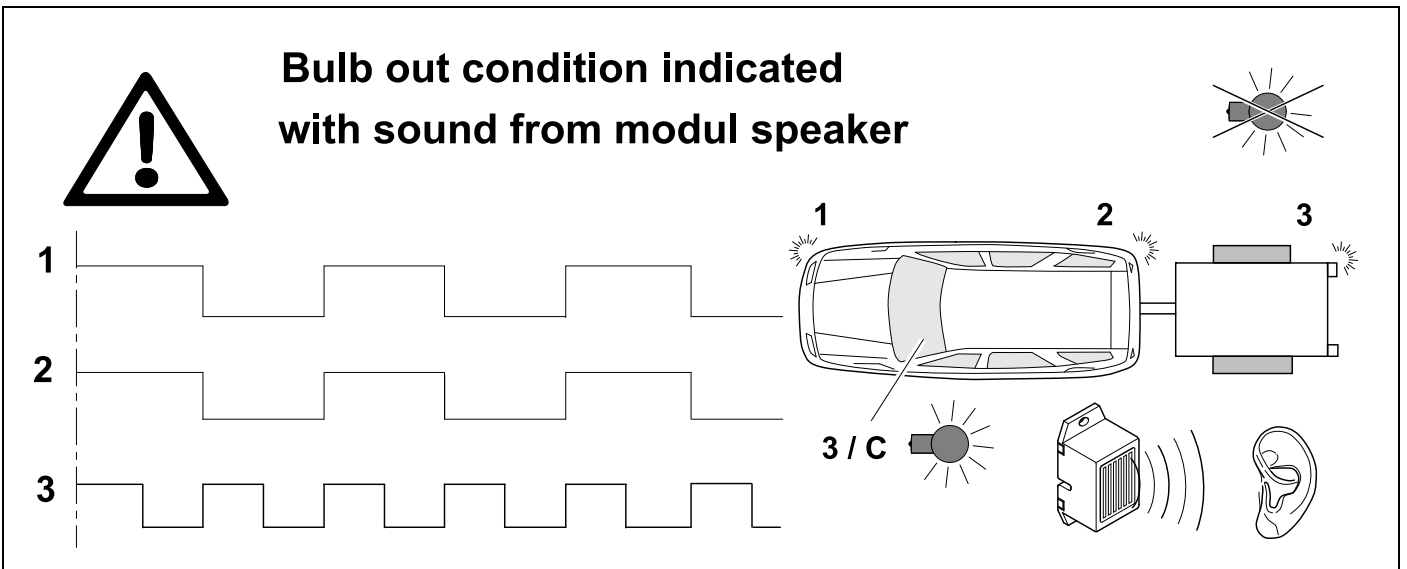

17

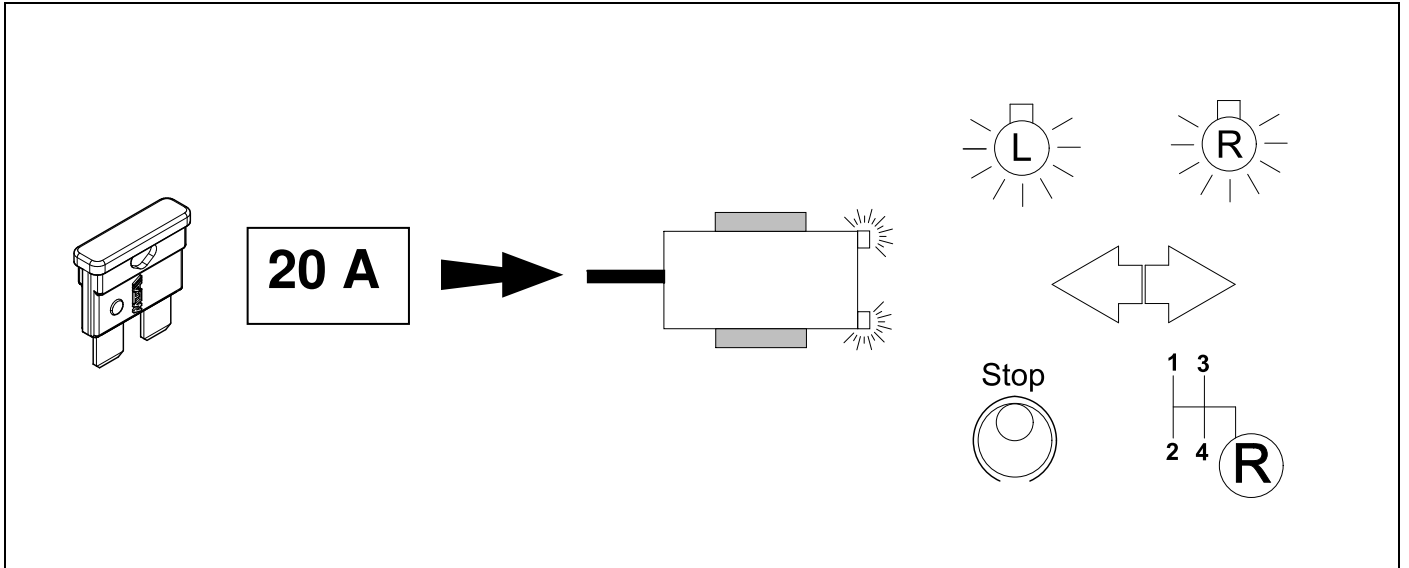

### 18 CHECK BULB OUT DETECTION

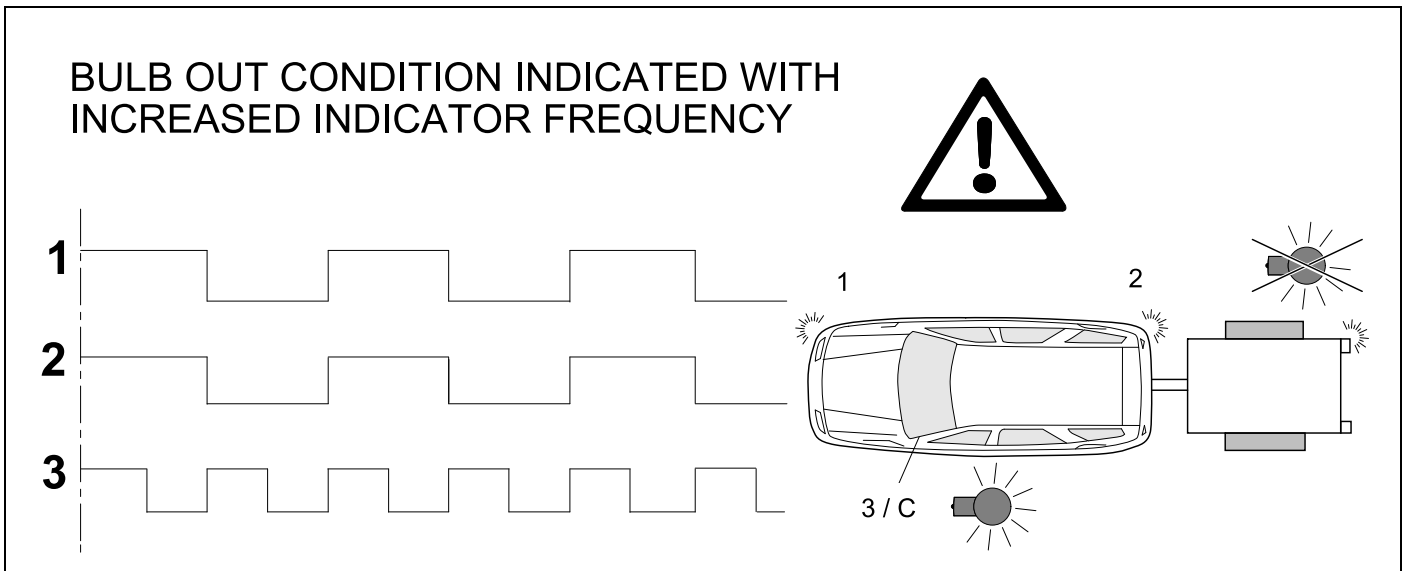

19

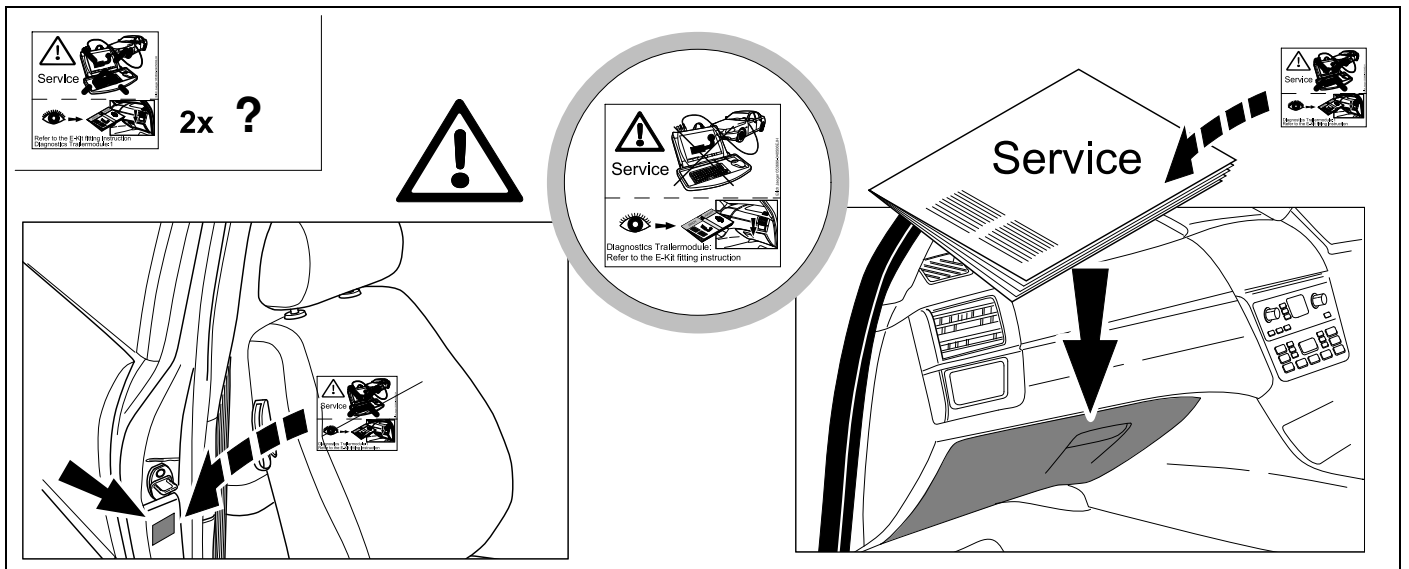

# Status LED for self-diagnosis

## Operation Support

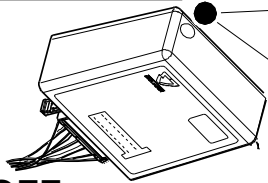
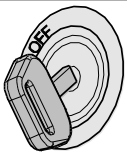

No CAN-Data =



Standby / Sleepmode



Ignition OFF

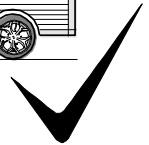
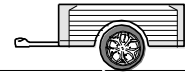
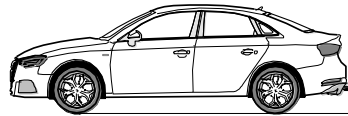
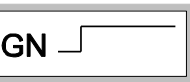
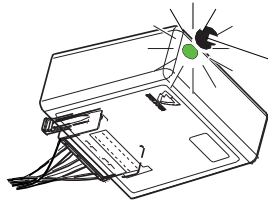

Ignition ON

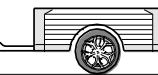
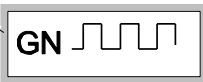
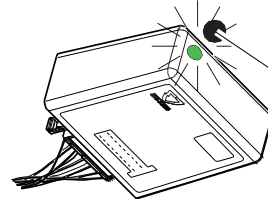

Ignition ON

## Failure Support

CAN-Data Wire



1x max. 5 min.

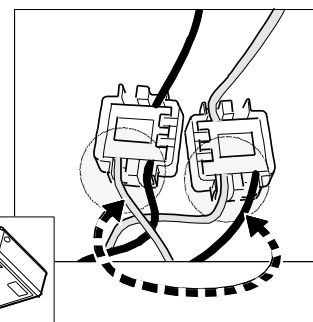
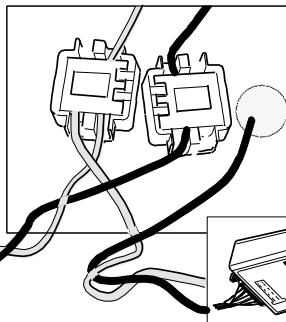
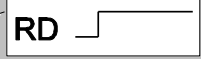
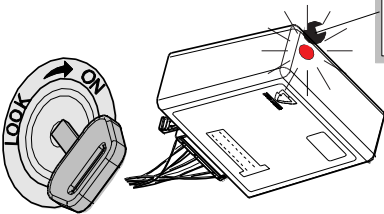

Ignition ON

Failure indicated by the module LED glowing red for a maximum of 5 minutes. If trailer connected the tail lights will also glow indicating failure of CAN signal.

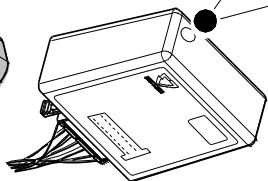
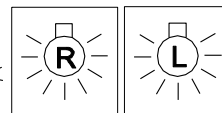

or

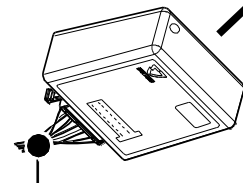
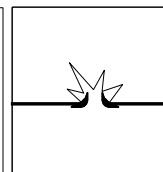
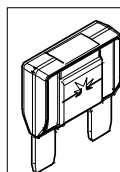
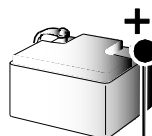
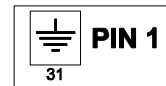

Ignition ON









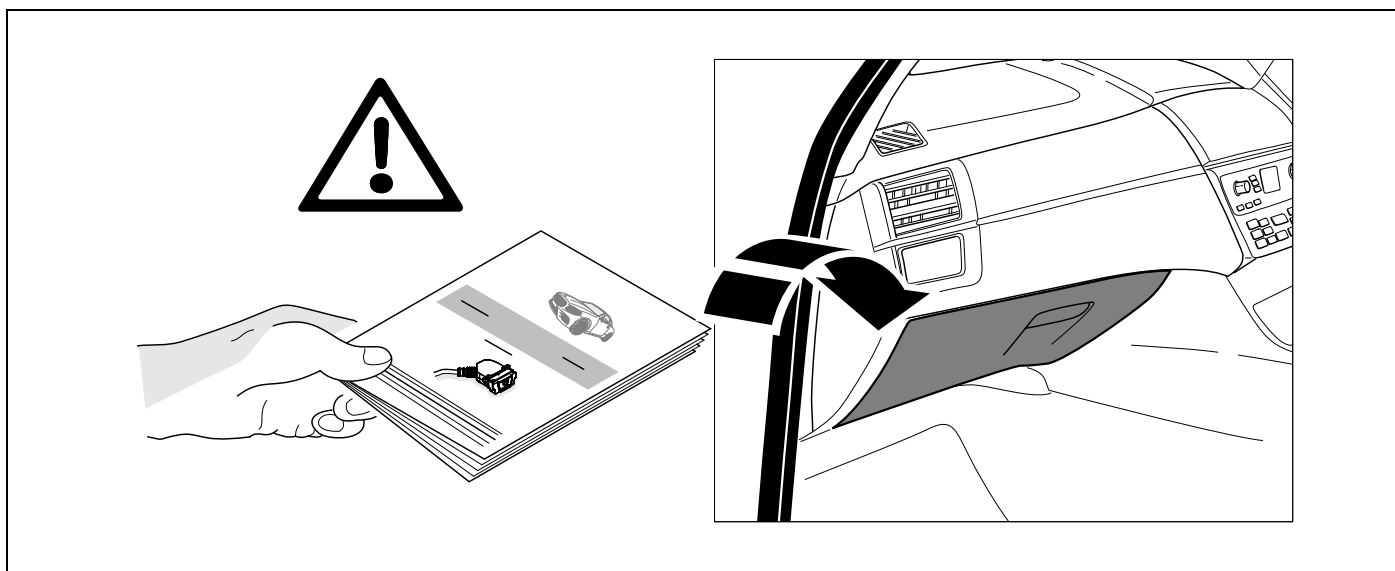

Subject to change in terms of construction, equipment and colour, and may contain errors.  
The information and illustrations are non-binding.