

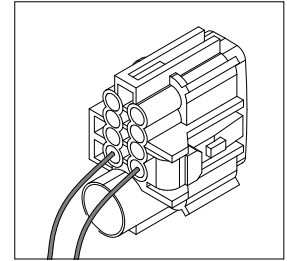

ERICH JAEGER

Installation instructions

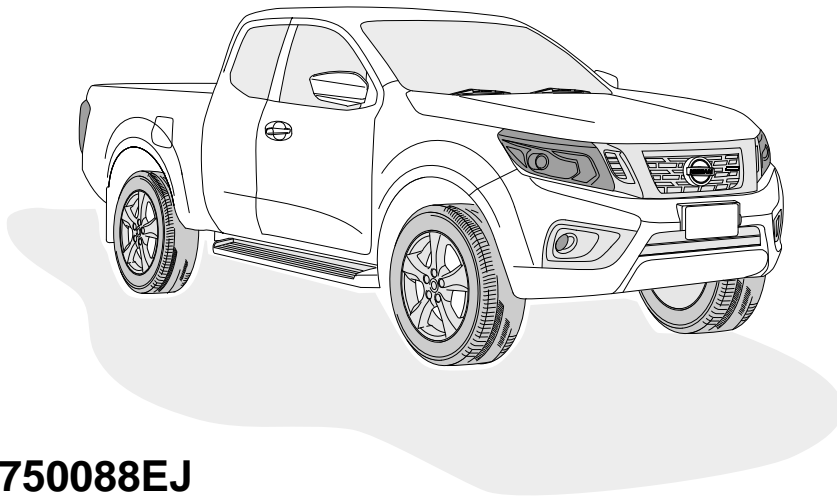

**Vehicles without
Power Supply Preparation
Use extension kit**

721149

750088EJ

NISSAN Navara

01/16 >>



SCAN FOR
LATEST
INSTRUCTIONS

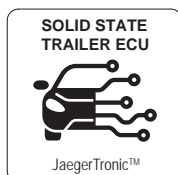
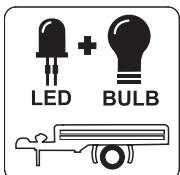
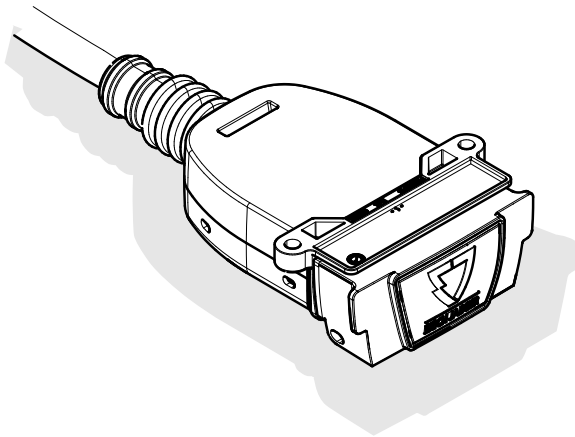

Reference:

The following information must be reviewed before beginning the assembly:

The installation instructions are to be thoroughly read.

The installation should be carried out by qualified personnel with the relevant technical knowledge. The vehicle manufacturers' current technical notices and information on retrofitting must be followed. The removal and replacement instructions found in the current repair manuals must be followed.

It must be ensured that the vehicle is technically suitable for the installation of a trailer hitch.

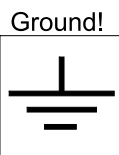
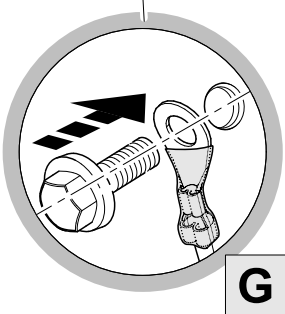
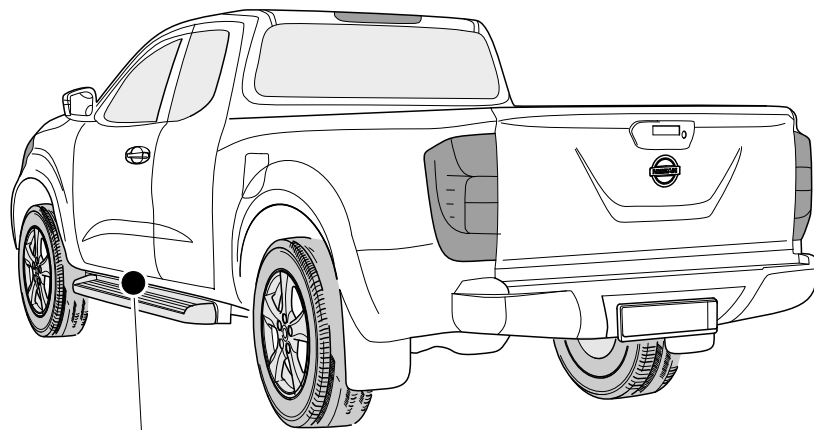
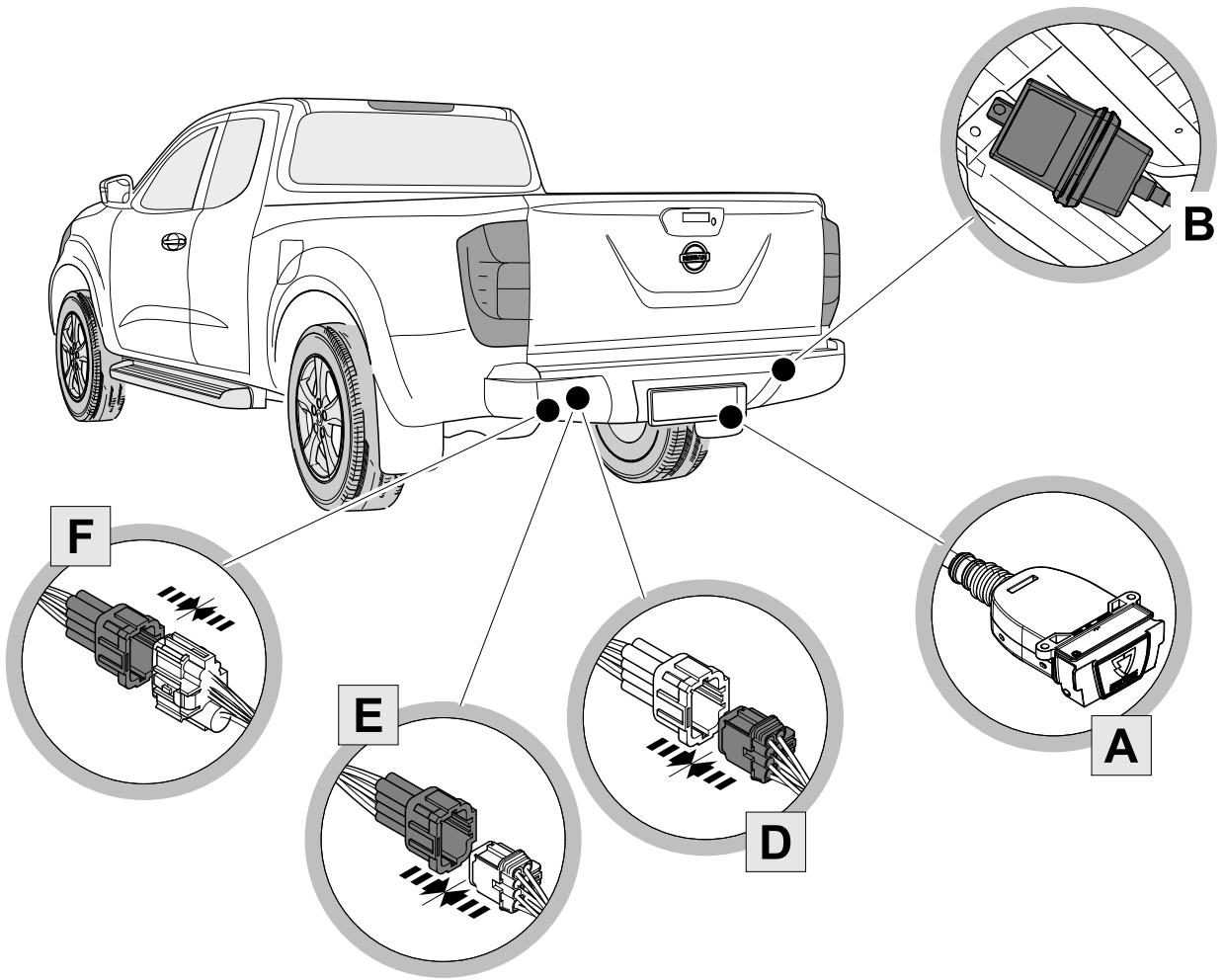

KIT

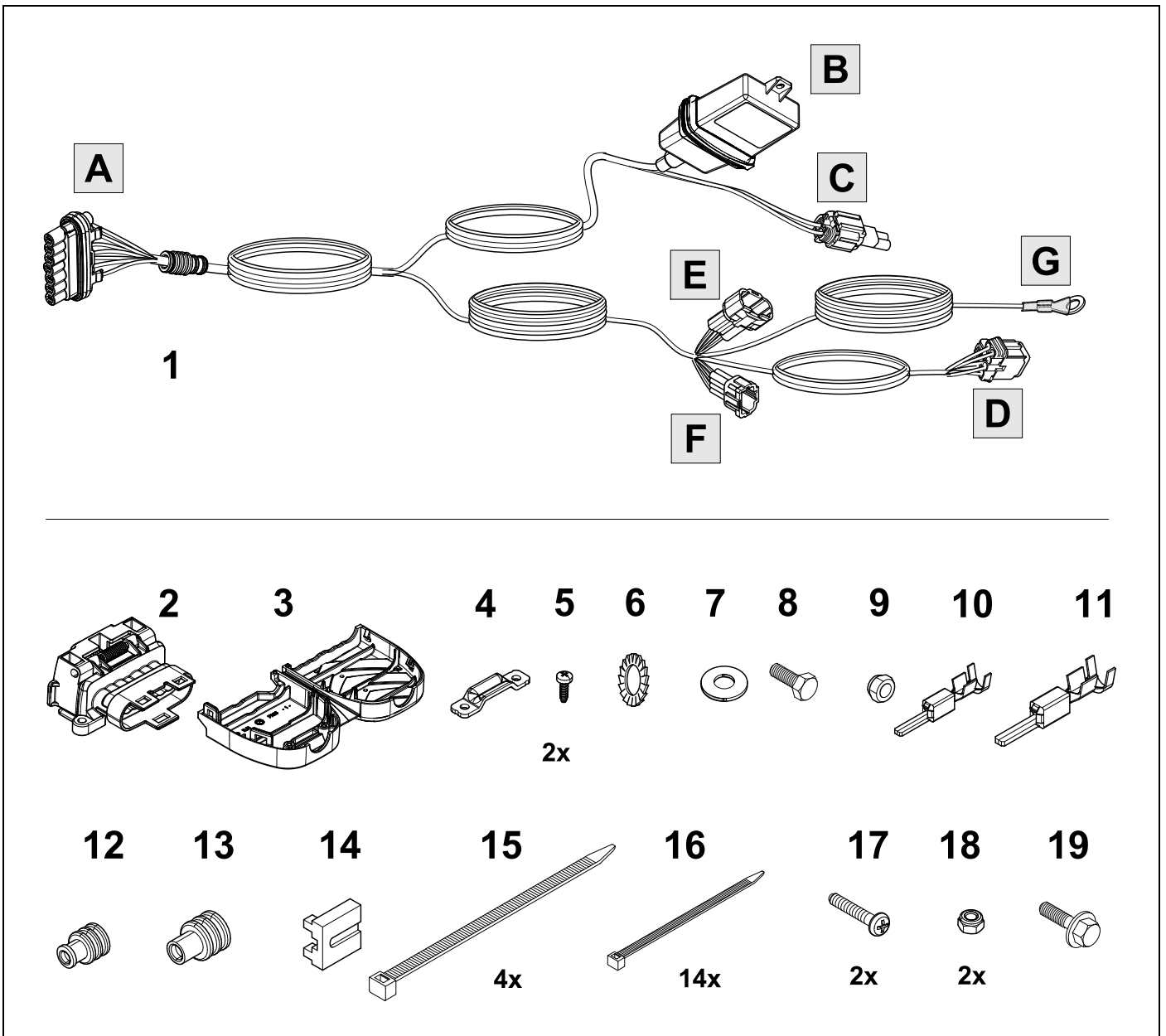

TOOLS

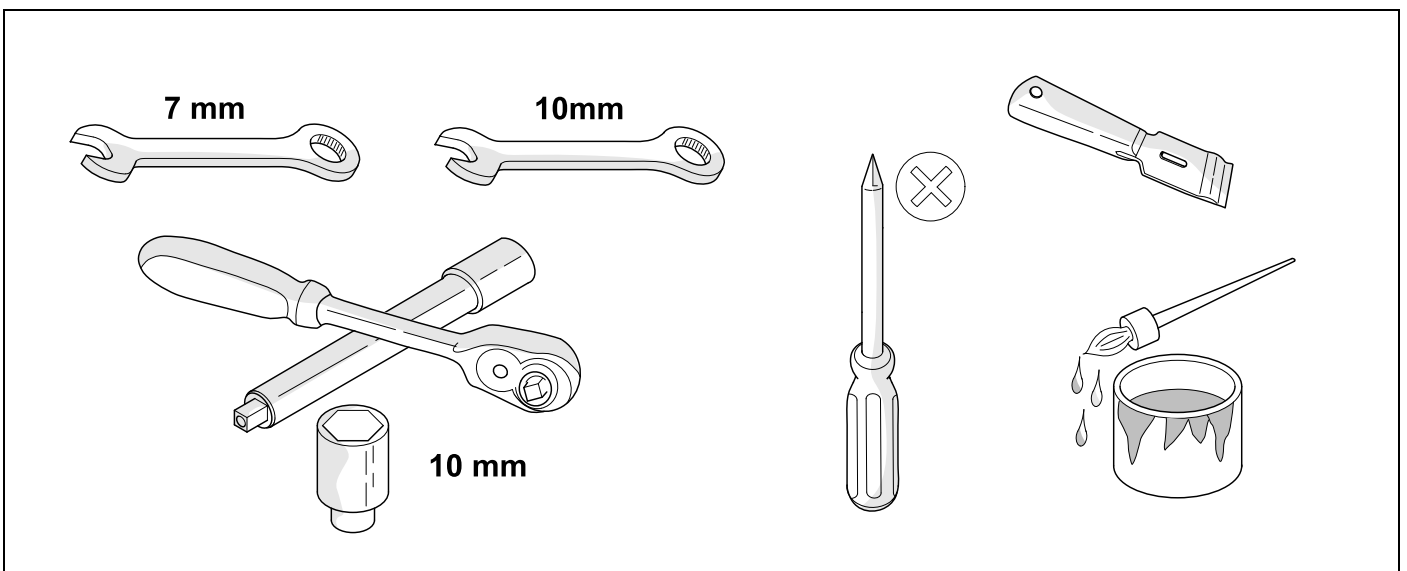

1

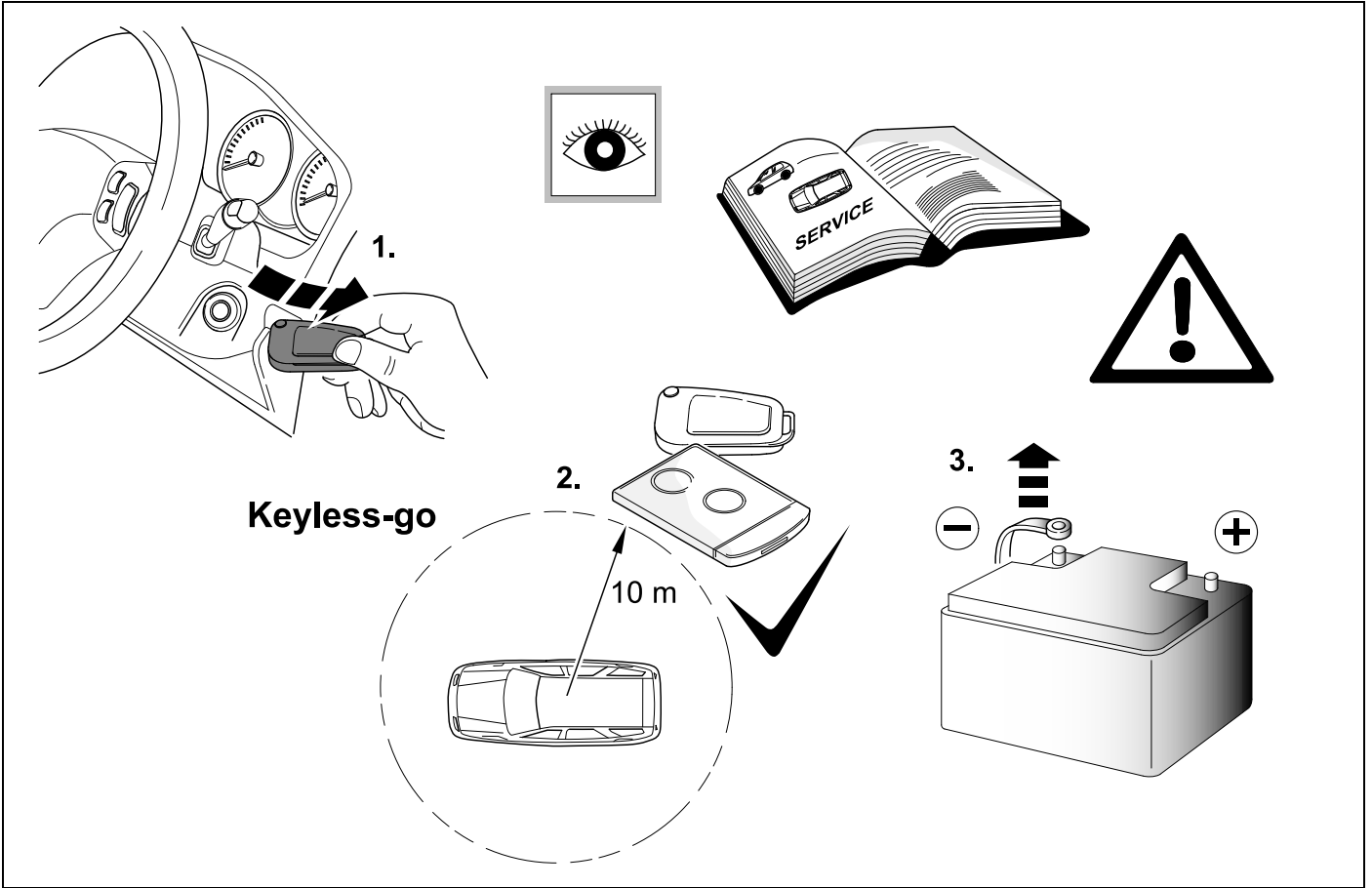

2

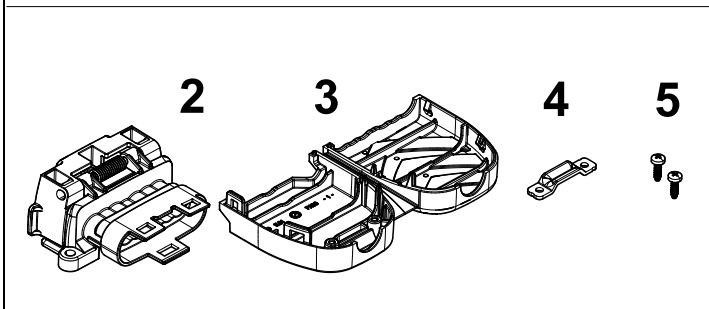
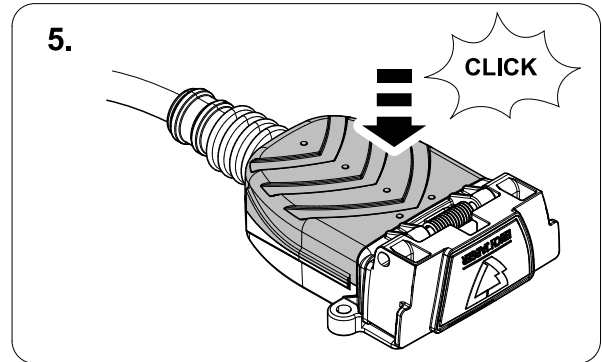
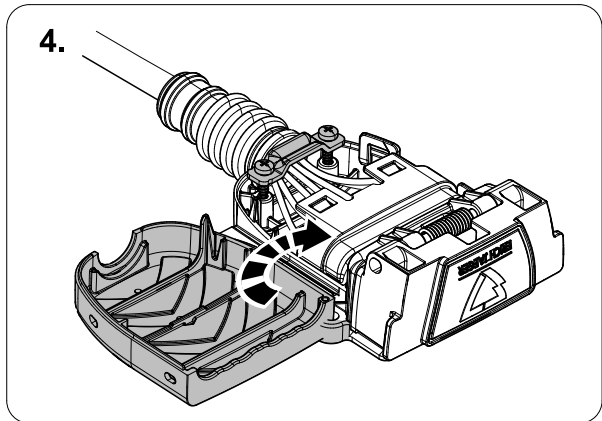
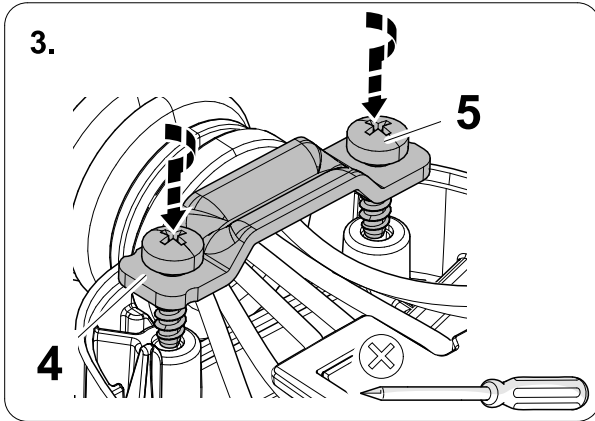
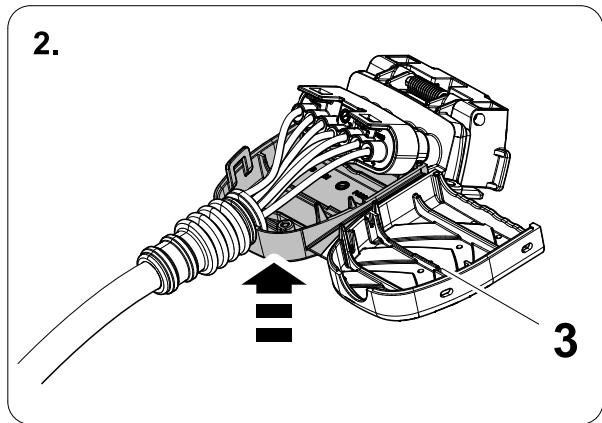
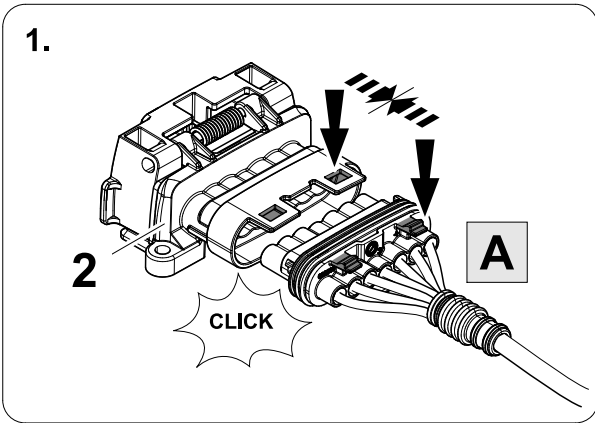

3

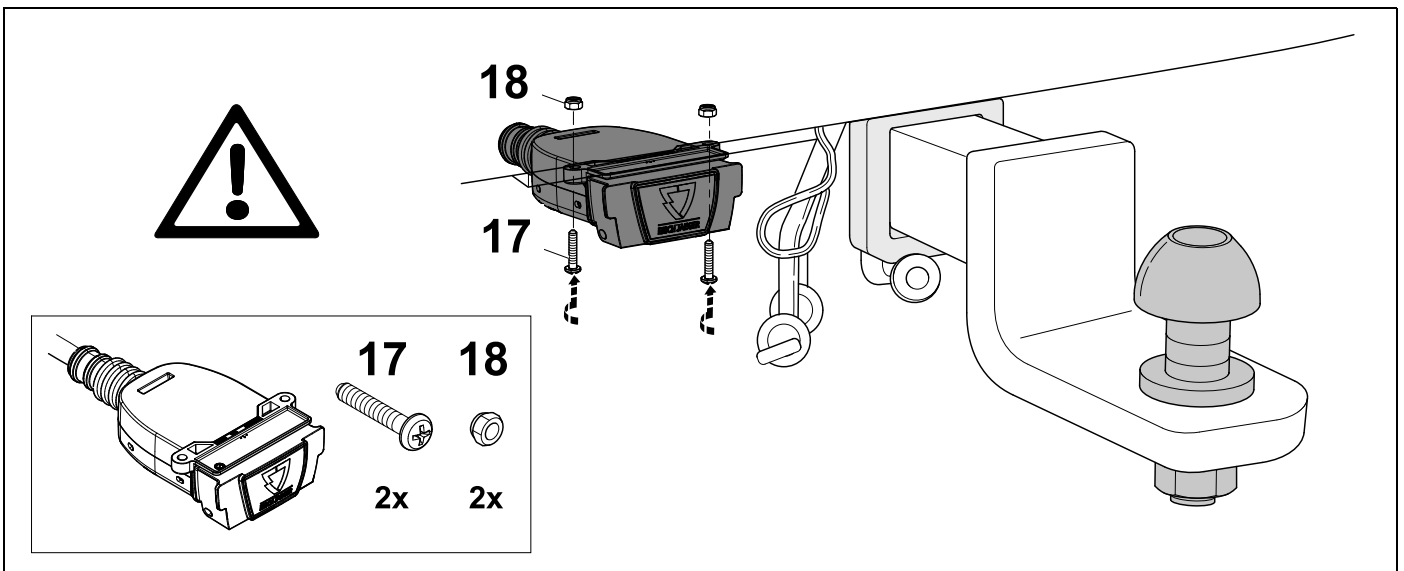

4



5

1	ye	
2	bk	
3	wh	
4	gn	
5	bu	
6	rd	
7	bn	

5	bk	wh	gy	gn	rd	bu	ye	bn	pu	or	no
---	----	----	----	----	----	----	----	----	----	----	----

	black	white	grey	green	red	blue	yellow	brown	purple	orange	not occupied
--	-------	-------	------	-------	-----	------	--------	-------	--------	--------	--------------

6

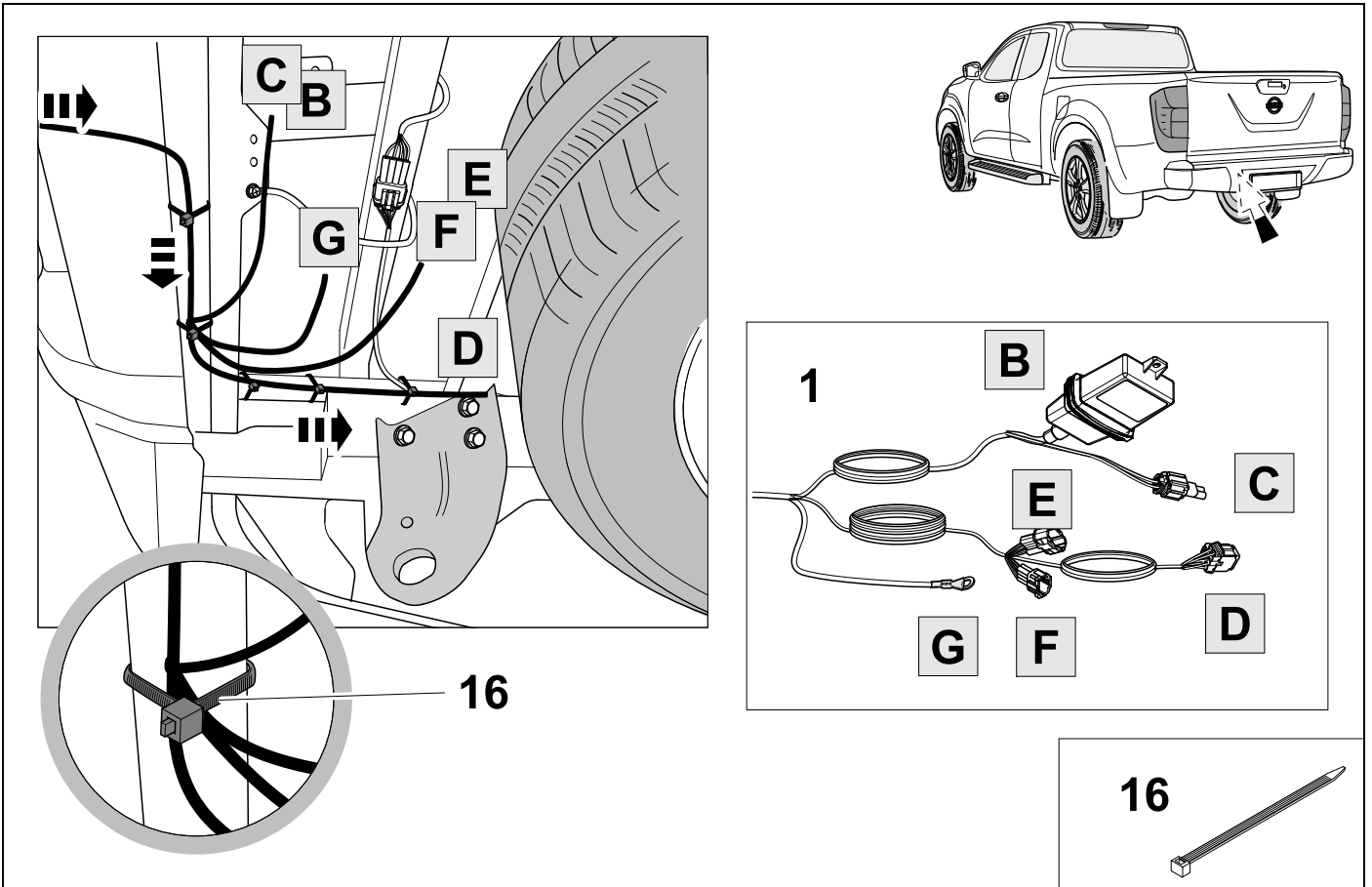

7



Module to be fitted out of the way on the chassis rail so that it is not submersed in water or exposed to direct dirt blast. Also ensure you use sufficient tie straps to secure the harness close to the module to minimize pulling on the module.

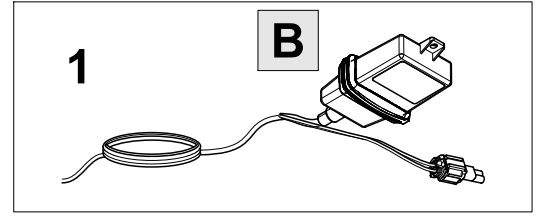
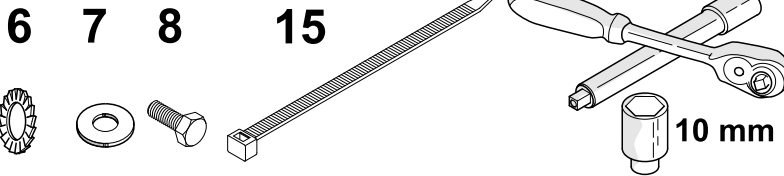
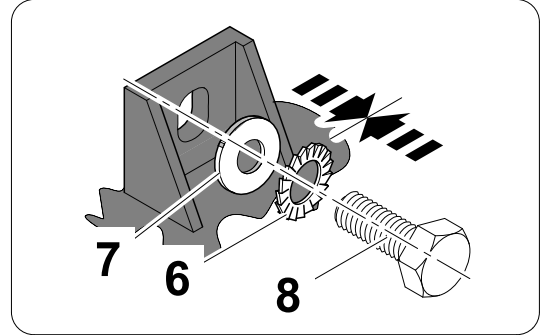
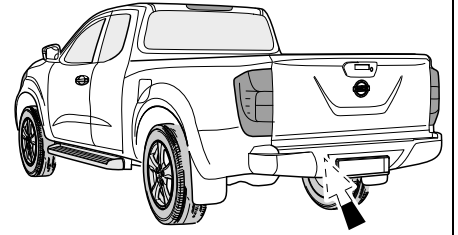
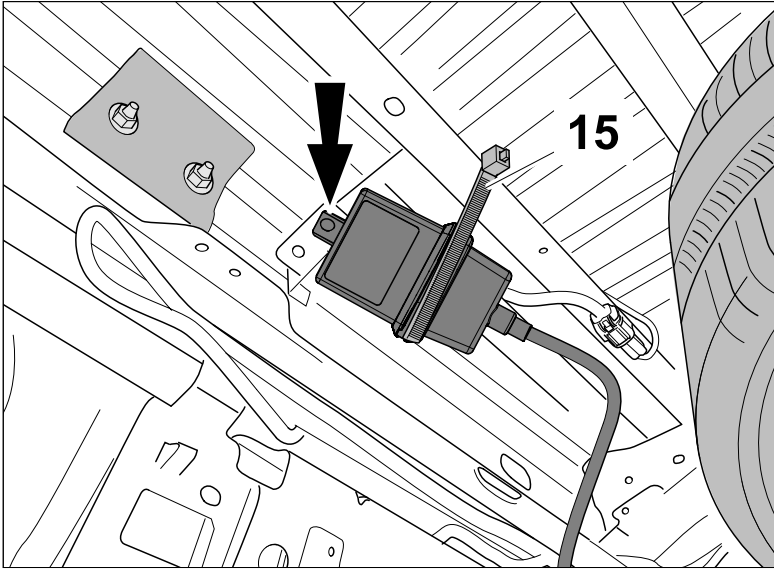

8

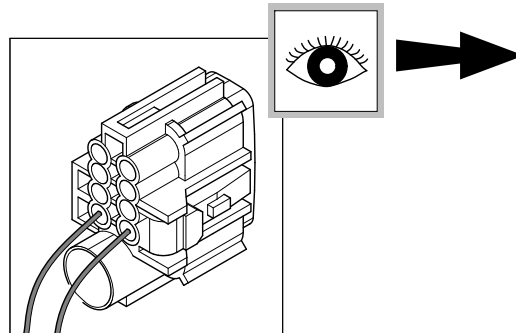
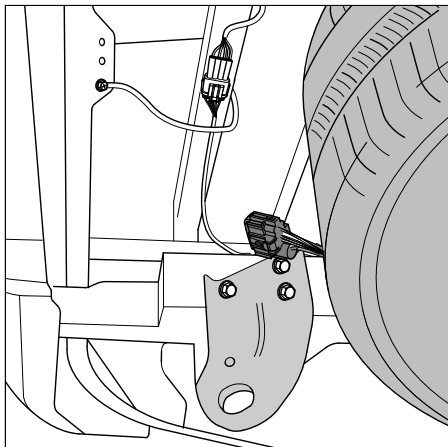
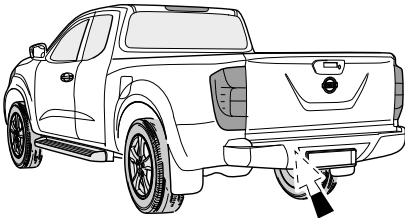

OPTION A

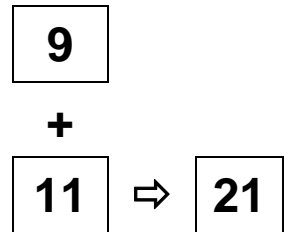

OPTION B

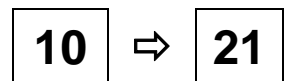
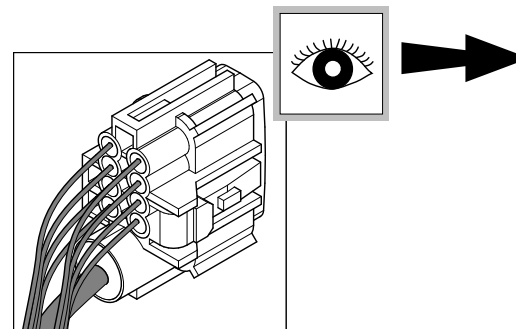

9

OPTION A

use
Etensions Kit
721149

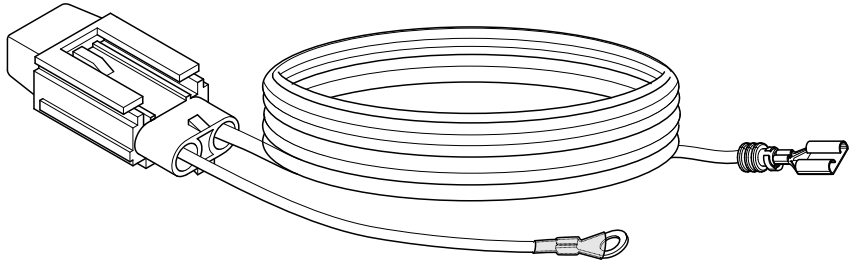

10

OPTION B

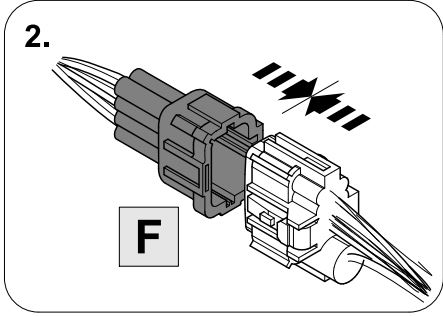
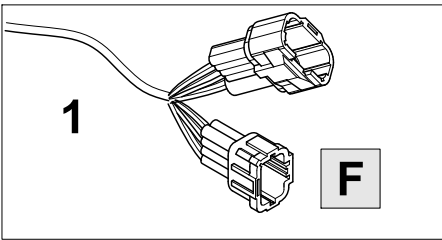
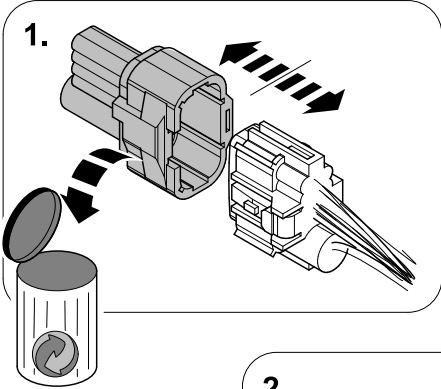
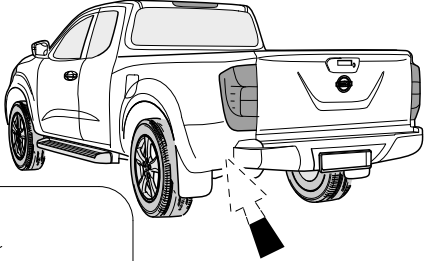
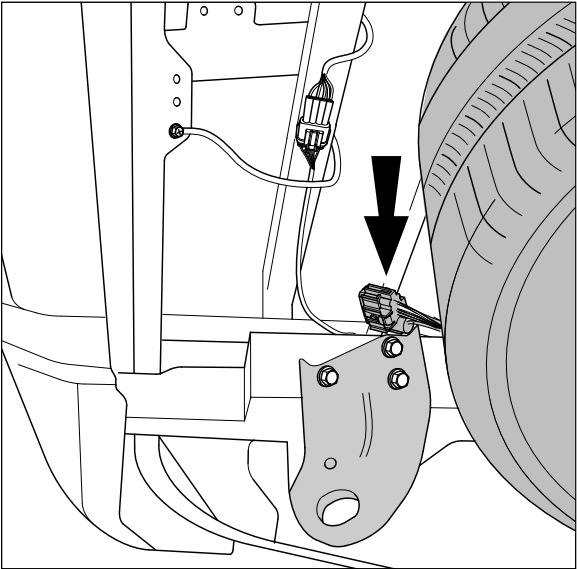

11

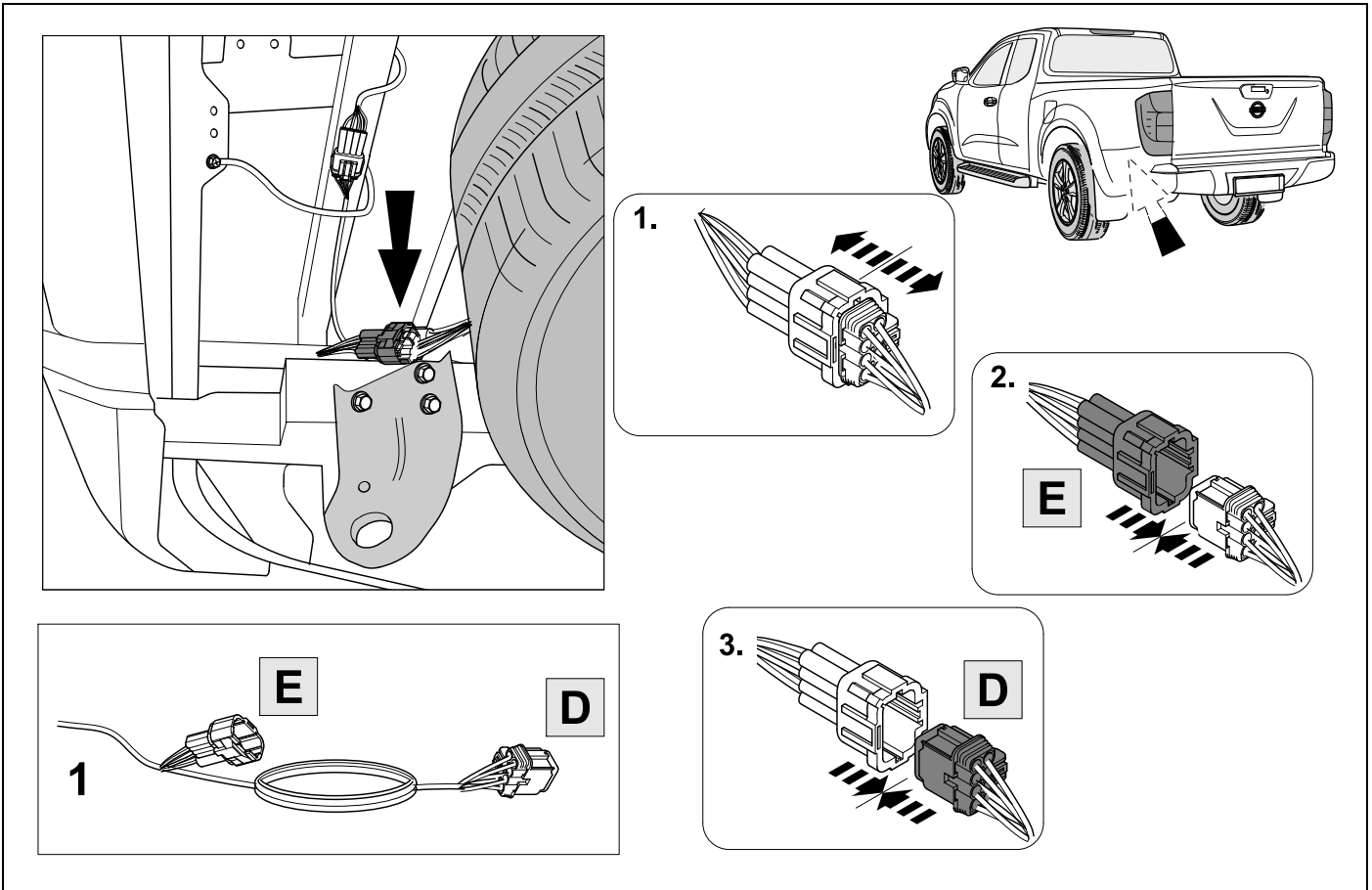

12

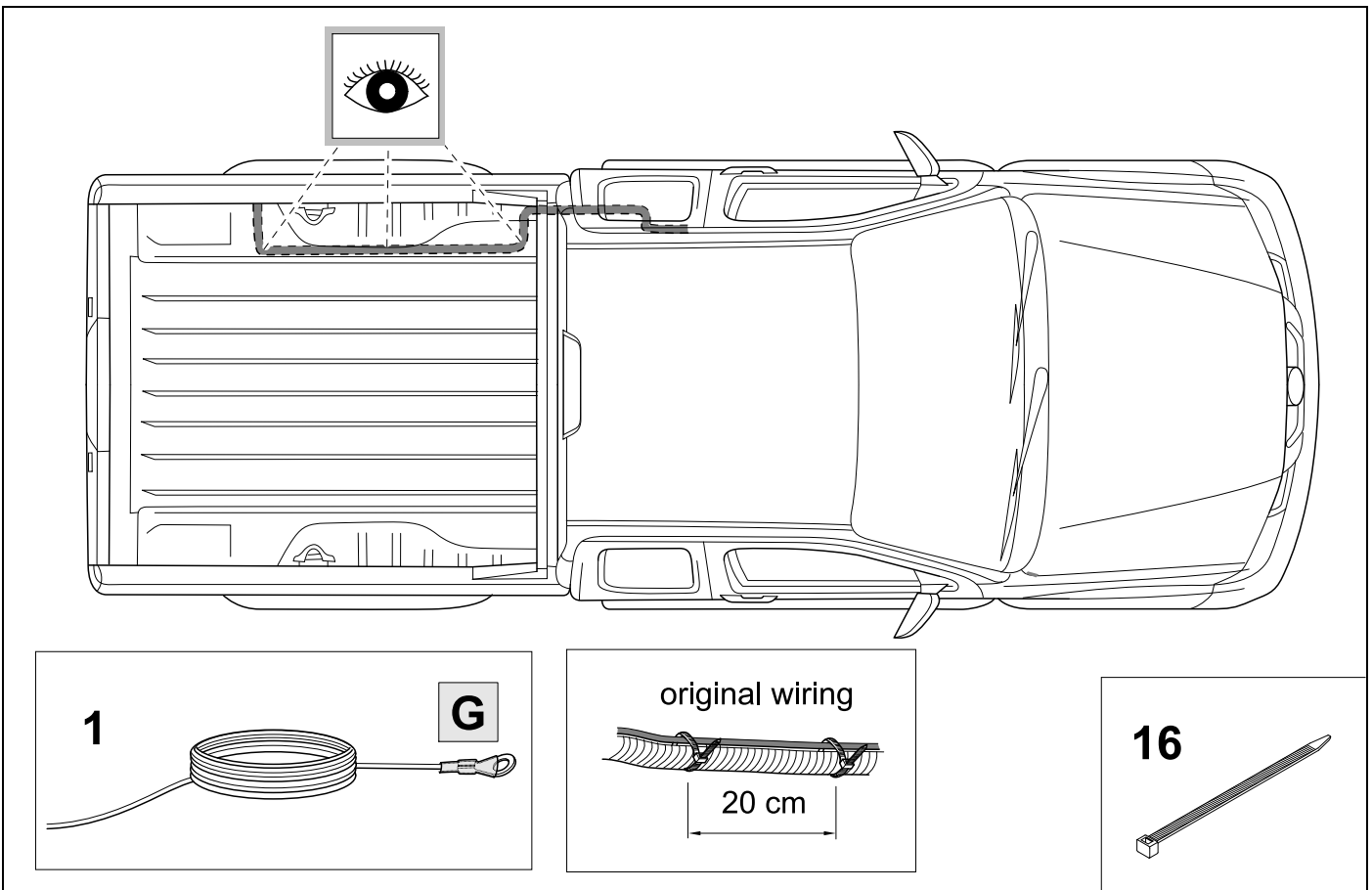

13

OPTION 1

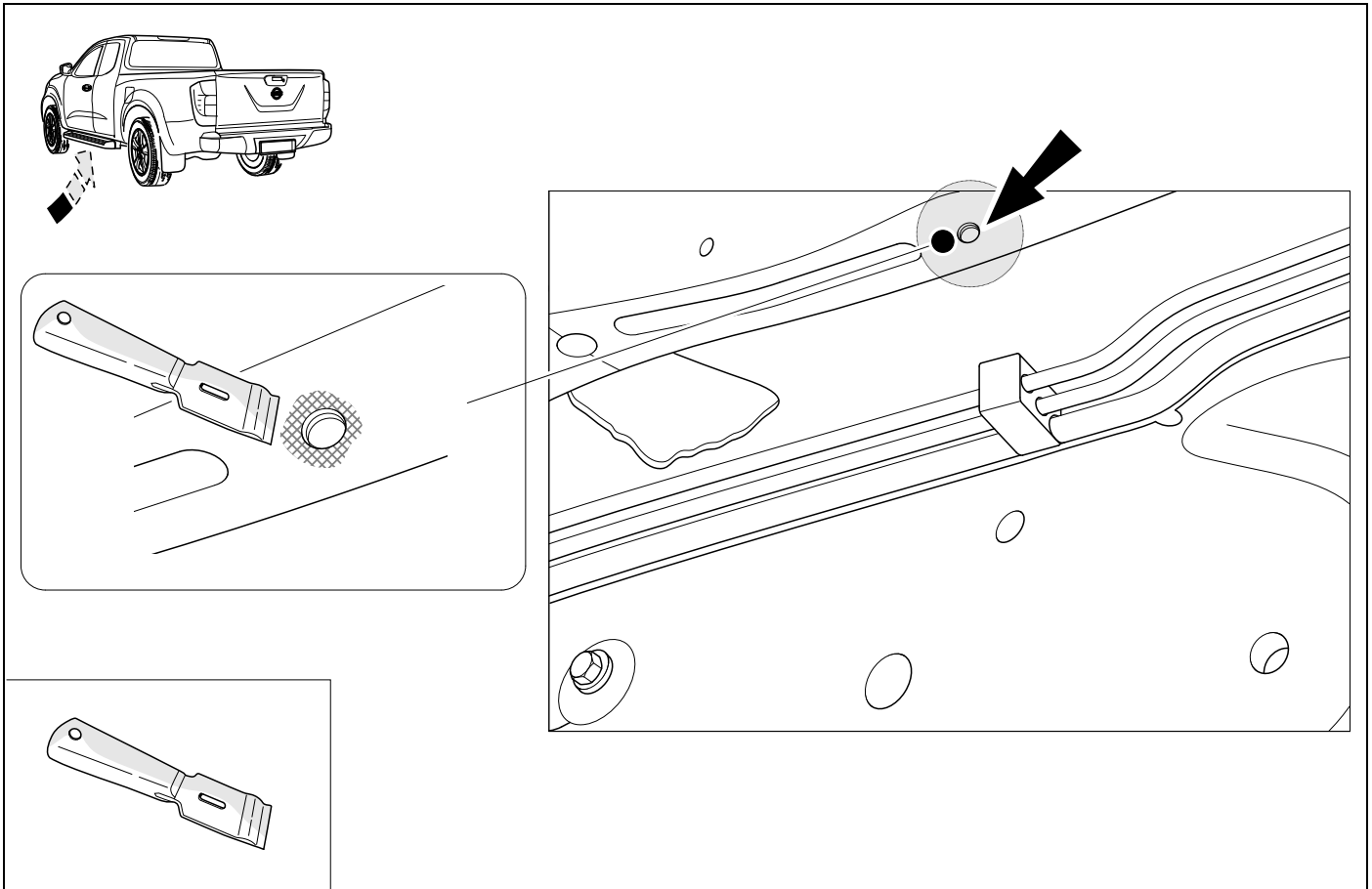

14

OPTION 1

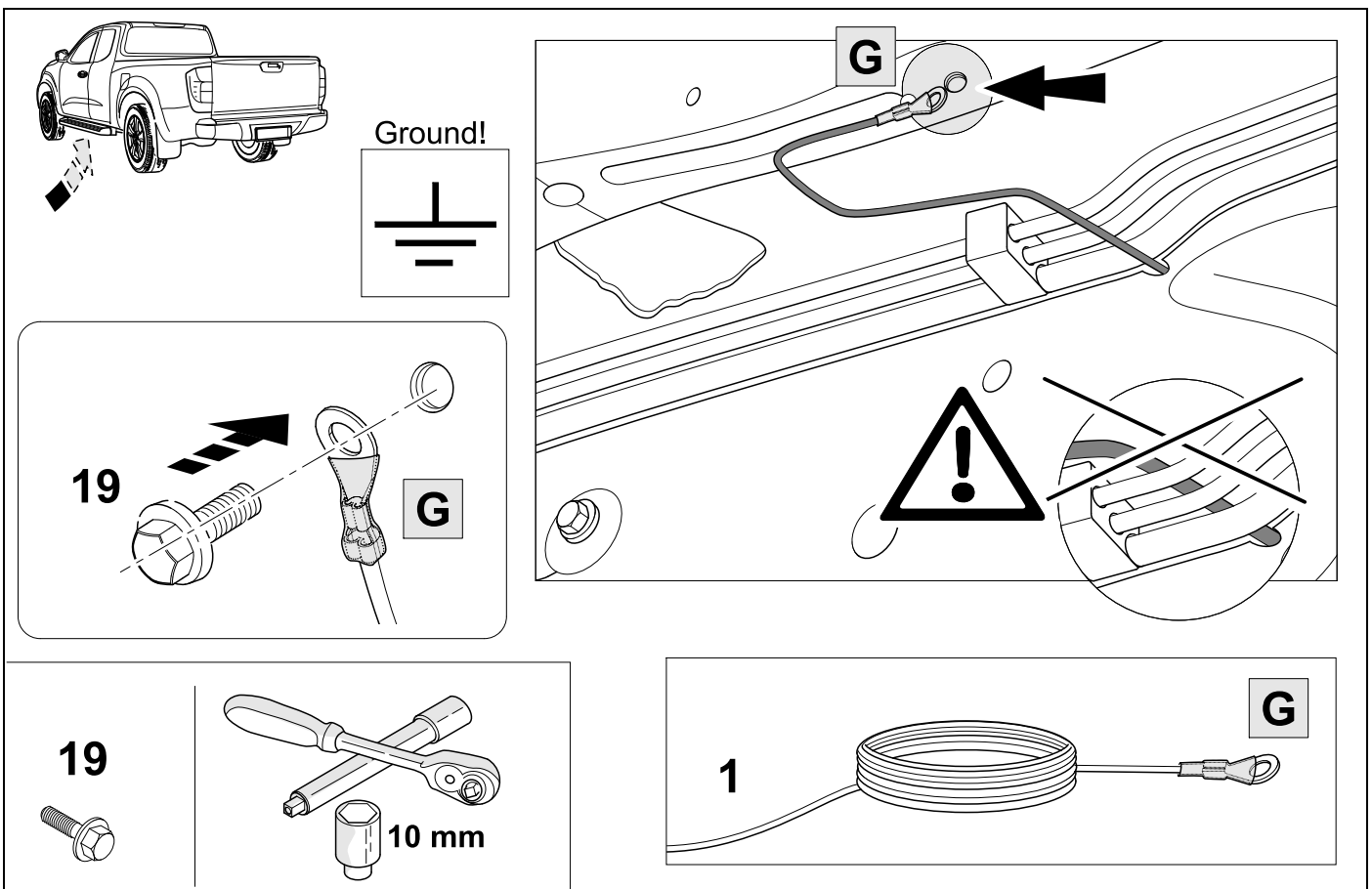

15

OPTION 1

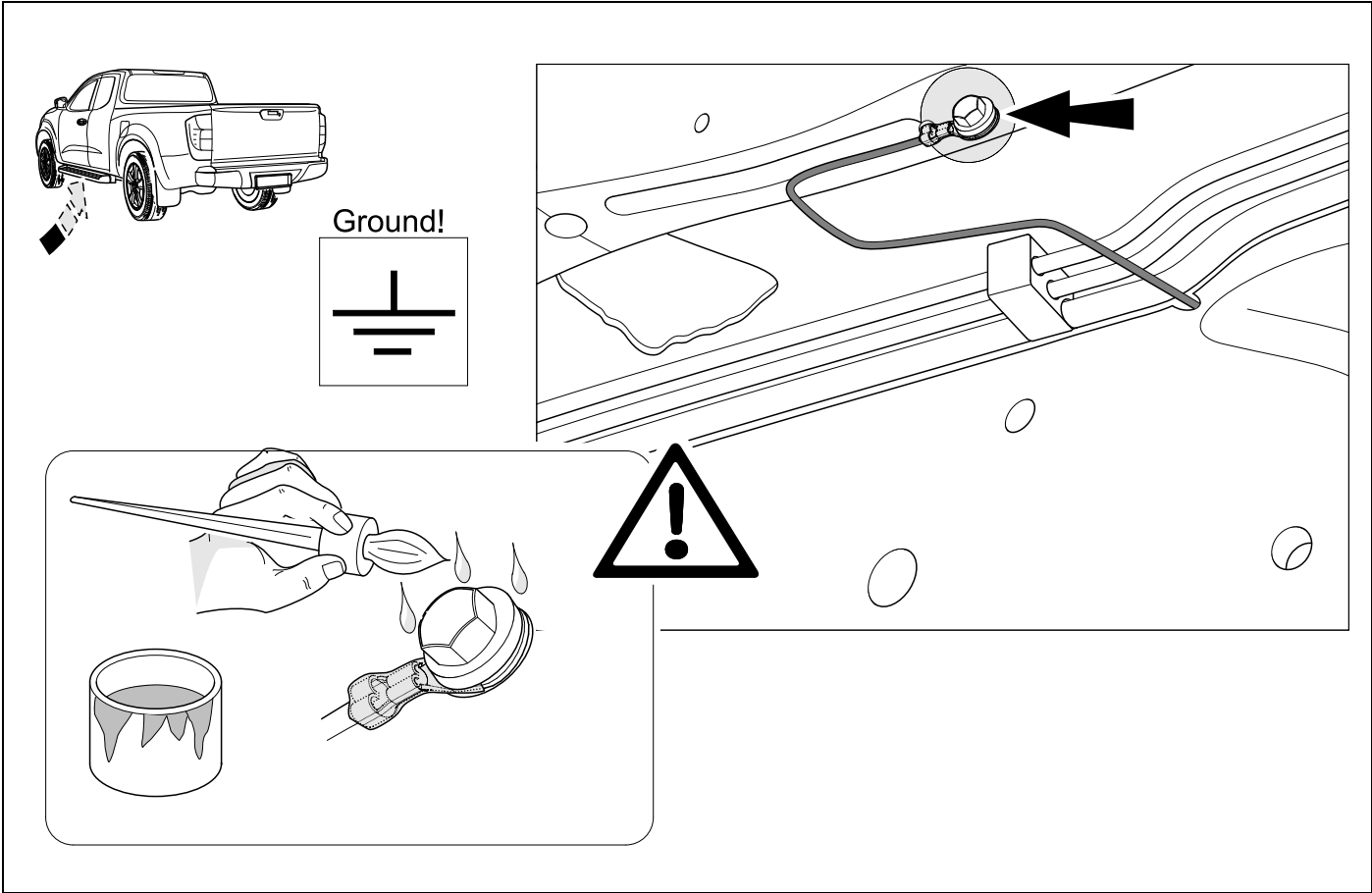

16

OPTION 2

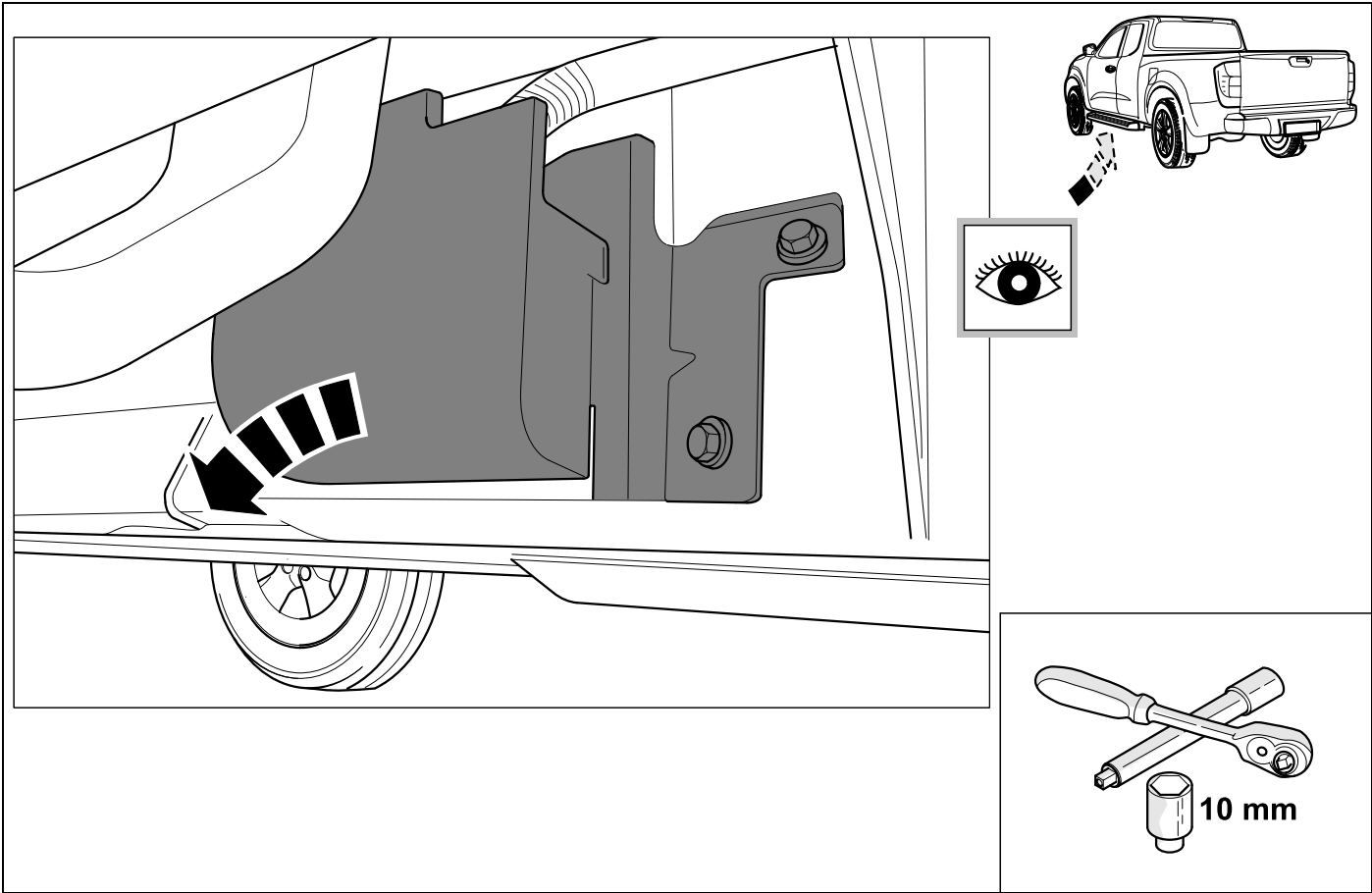

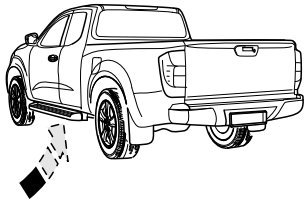

Ground!

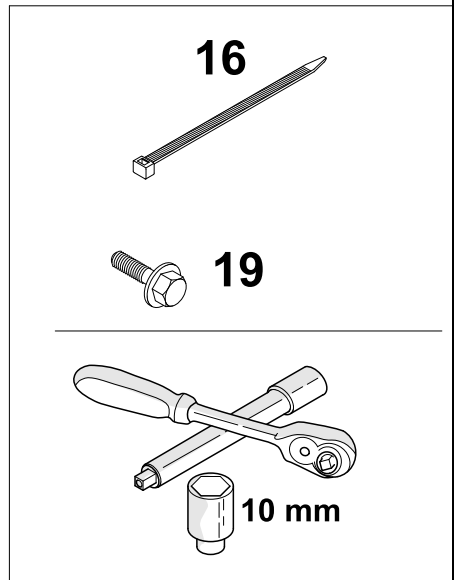
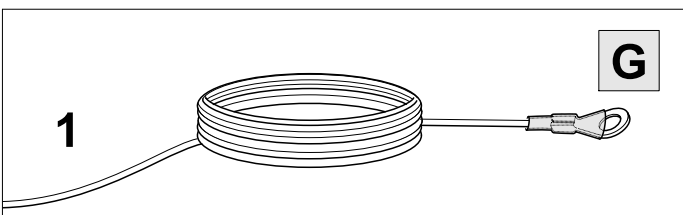
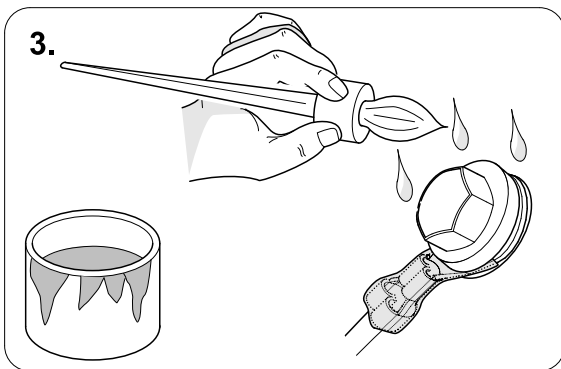
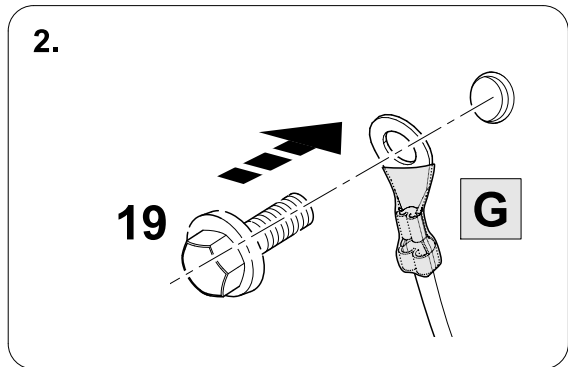
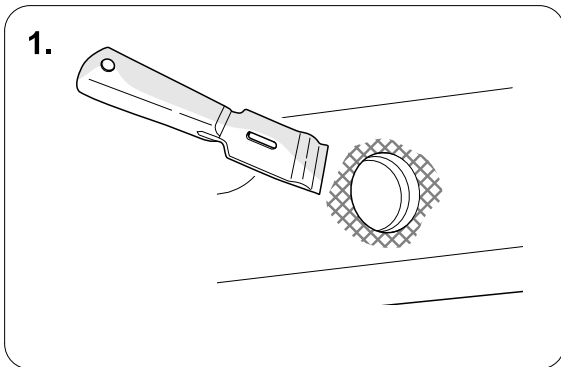
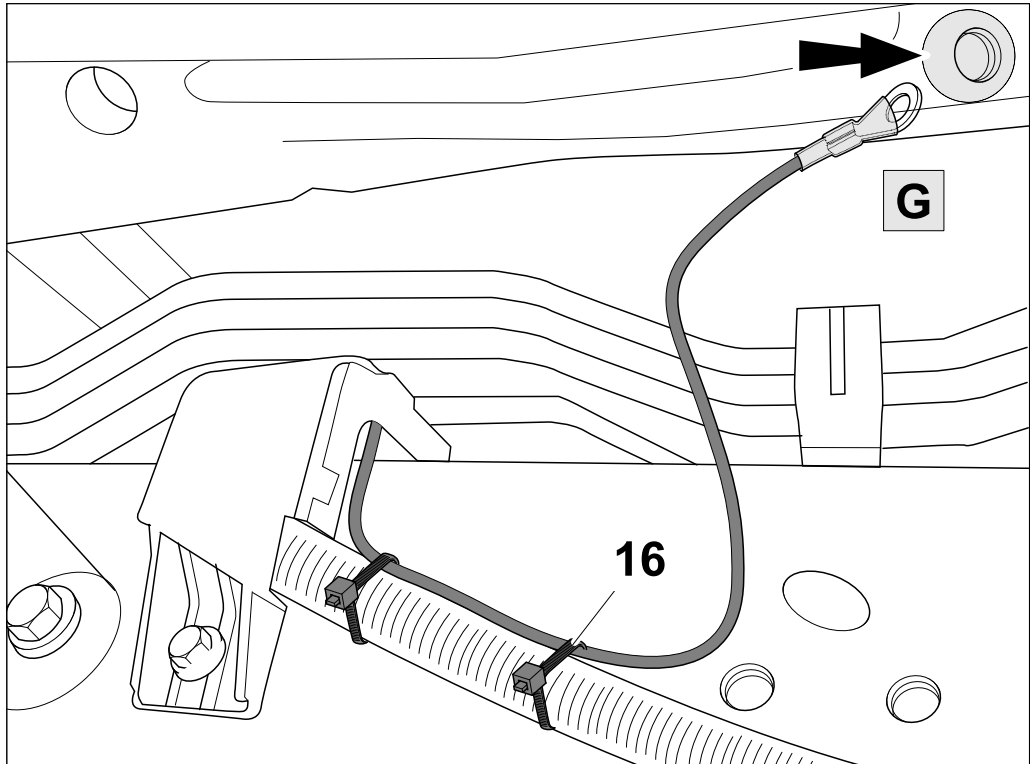
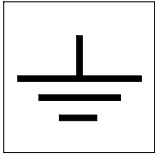

**BRAKE
CONTROLLER
PREPARED**

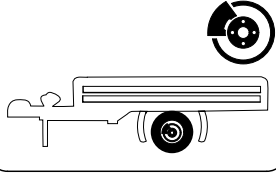

OPTIONAL



Trailer Brake Preparation

1.

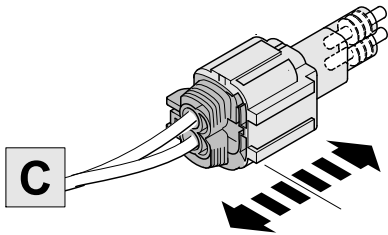

2.

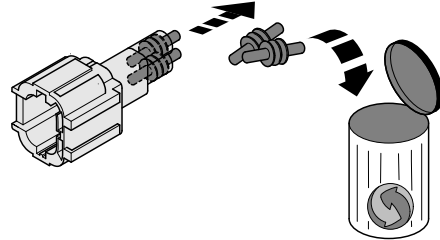

3.

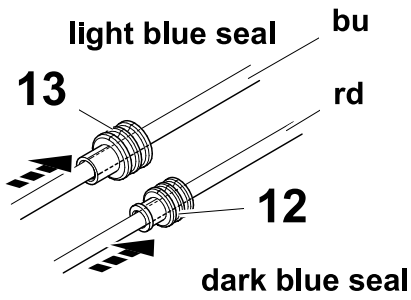

4.

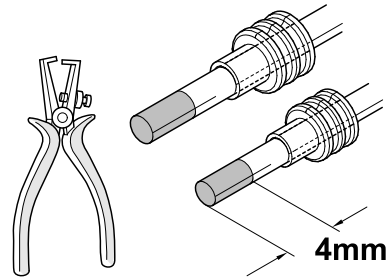

6.

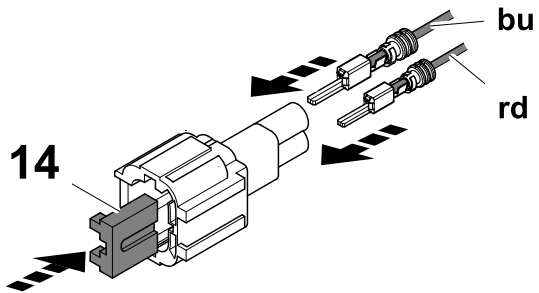

5.

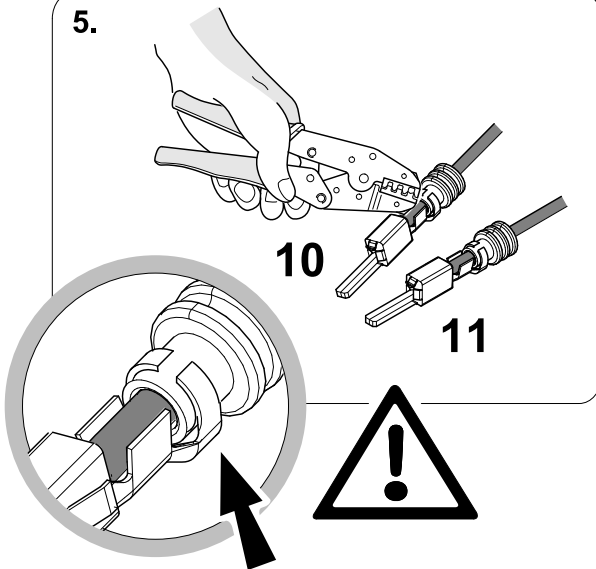

7.

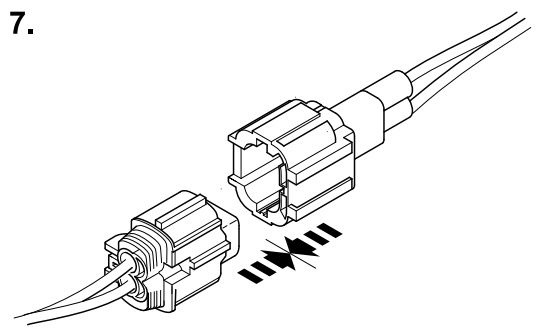

19

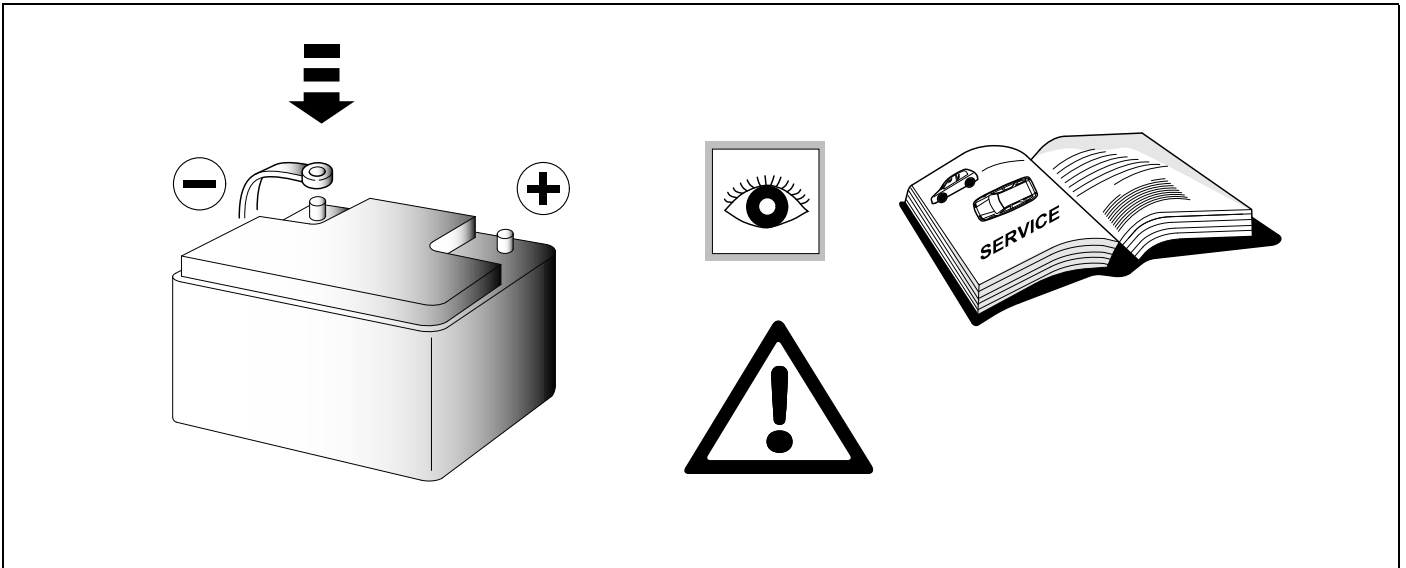

20

CHECK ALL LIGHTING FUNCTIONS

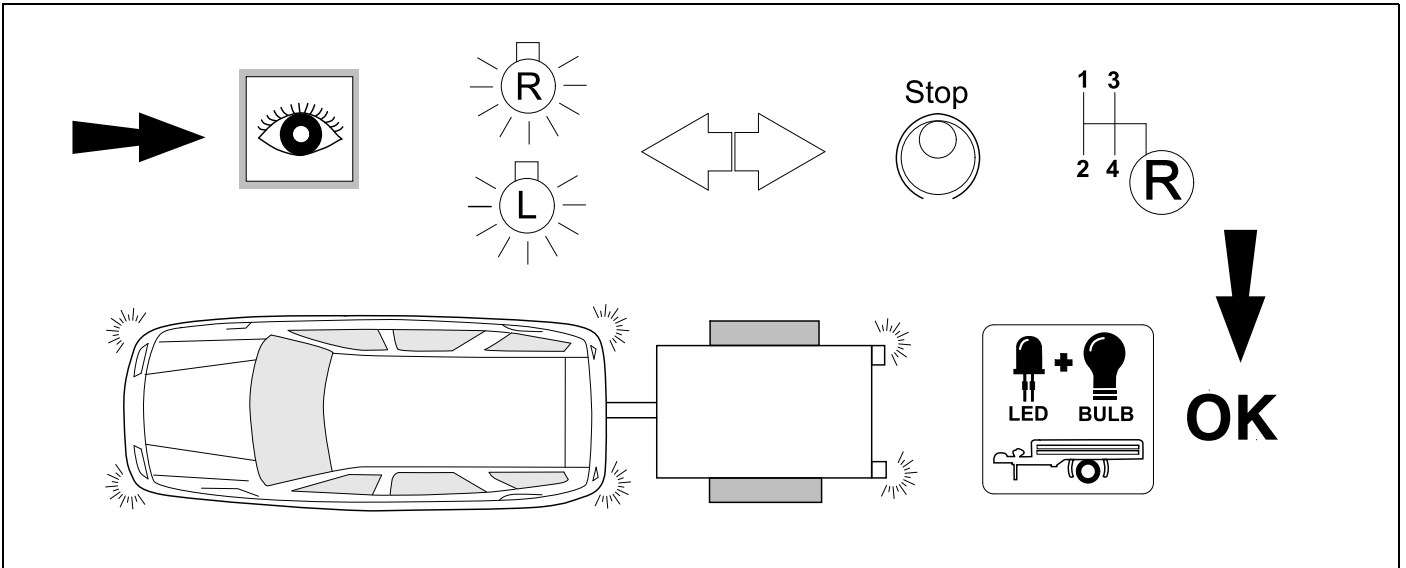

21

CHECK ALL LIGHTING FUNCTIONS

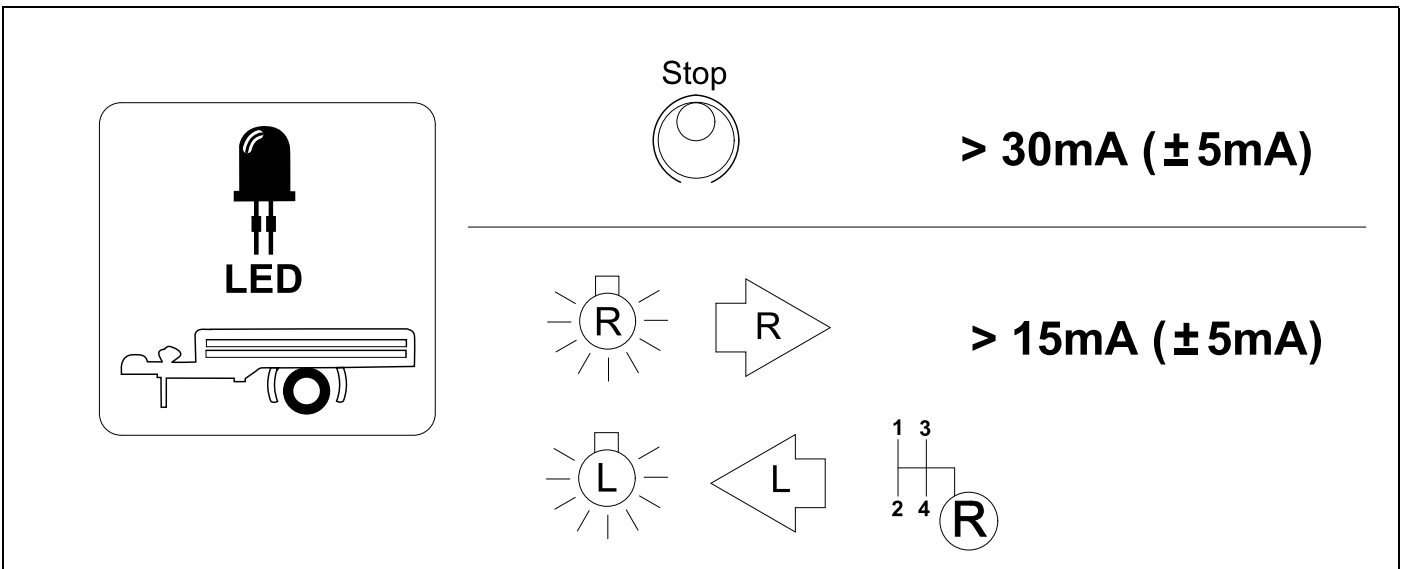

22

CHECK BULB OUT DETECTION

BULB OUT CONDITION INDICATED WITH INCREASED INDICATOR FREQUENCY

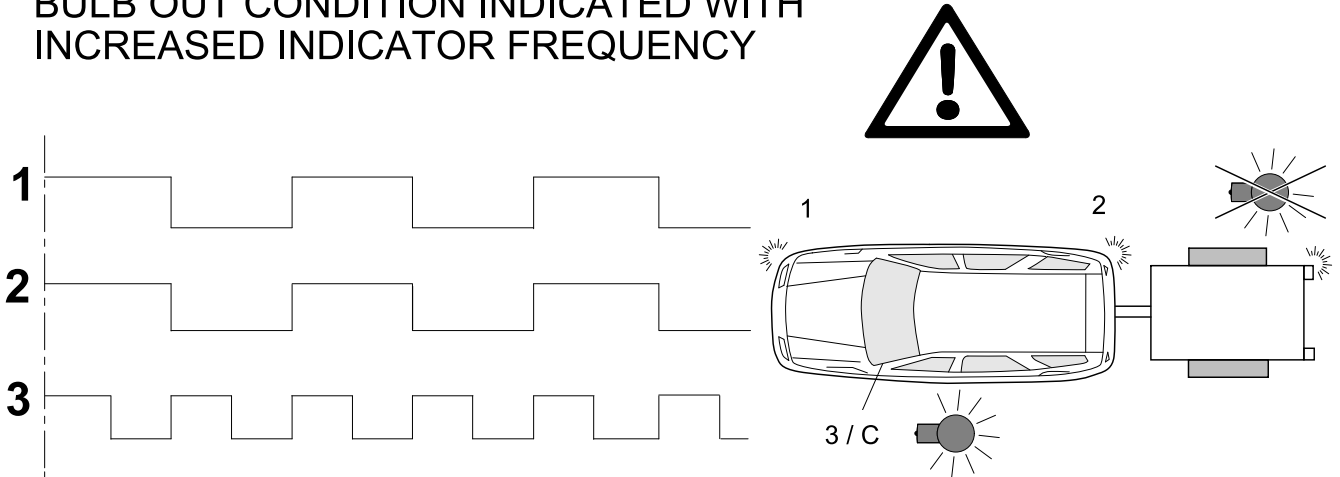

23

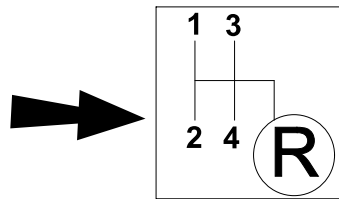
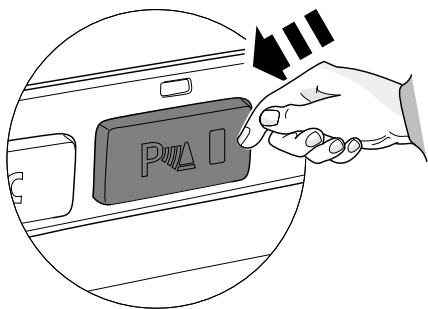
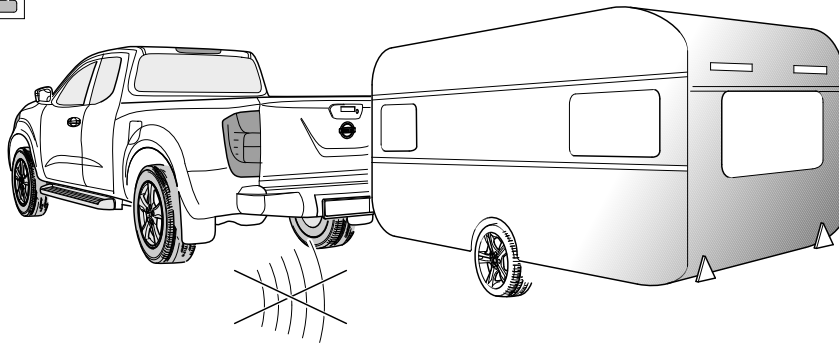
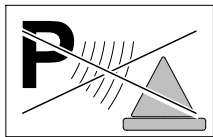

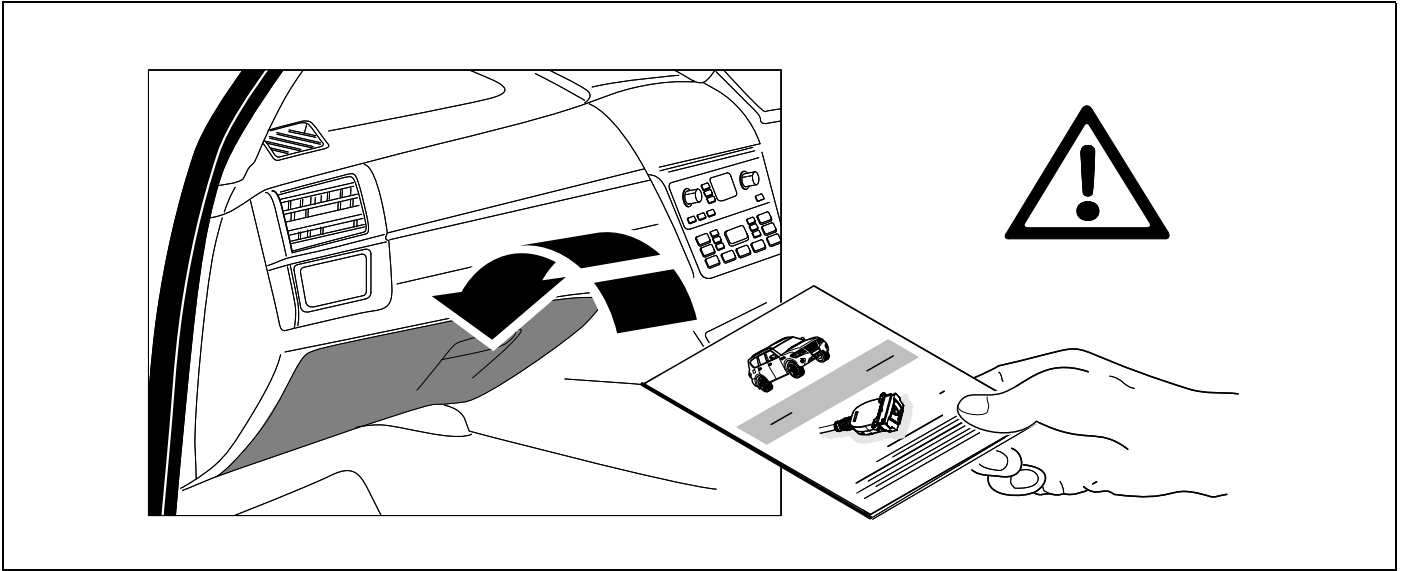

Subject to change in terms of construction, equipment and colour, and may contain errors.
The information and illustrations are non-binding.