

INSTALLATION INSTRUCTIONS

8313- FIT KIT TO SUIT MAZDA BT-50 SDX TUB BODY VARIENTS 07-ON

NOTE: FITS IN CONJUNCTION WITH BT-50 TOWBARS HAVING BUMPER STEP

WARNING:

Do not, drill, cut, weld or otherwise modify the towbar.

If you are using electric welding on a motor vehicle, **always** check that the vehicle is not equipped with electronic engine or instrument management equipment. Failure to do so could **destroy** any onboard **computers**. If in doubt, check with the vehicle's manufacturer.

PLEASE READ INSTRUCTIONS THROUGH BEFORE YOU BEGIN

1. Ensure all hardware items have been included.
2. Remove the factory fitted step by removing the bolts as shown in fig 1. Do not discard the bolts as they are used to fit the towbar to the vehicle.
3. Lower the spare wheel.
4. Fit the towbar as per towbar fitting instructions.
5. Refit the bumper step by following the following steps:
 - a) The arms of the bumper steps on the SDX variants have to be pushed outwards on both ends by 8mm to provide clearance for the side arms of the towbar.
 - b) Discard the packer that comes in the towbar bolt pack as shown below.
 - c) On the driver & passenger sides, make the slots on the bumper step side arm mounting plate bigger by 8mm, by redrilling a hole beside it or grinding it as shown in fig 2.
 - d) Remove the bracket on the Passenger side bumper step arm as shown in fig 3 & discard it.
 - e) Replace the mounting bracket for the step as shown in fig 4 on both sides of the bumper step with the brackets provided in the kit.
 - f) On both sides of the bumper step, pack the arm of the step out by fitting the packer provided in the kit as shown in fig 5.
 - g) Refit the bumper step on the outside of the side arms of the towbar using the same bolts removed in step 2.
6. Refit the spare wheel.

BT-50 TUB BODY TOWBAR ASSEMBLY SHOWN

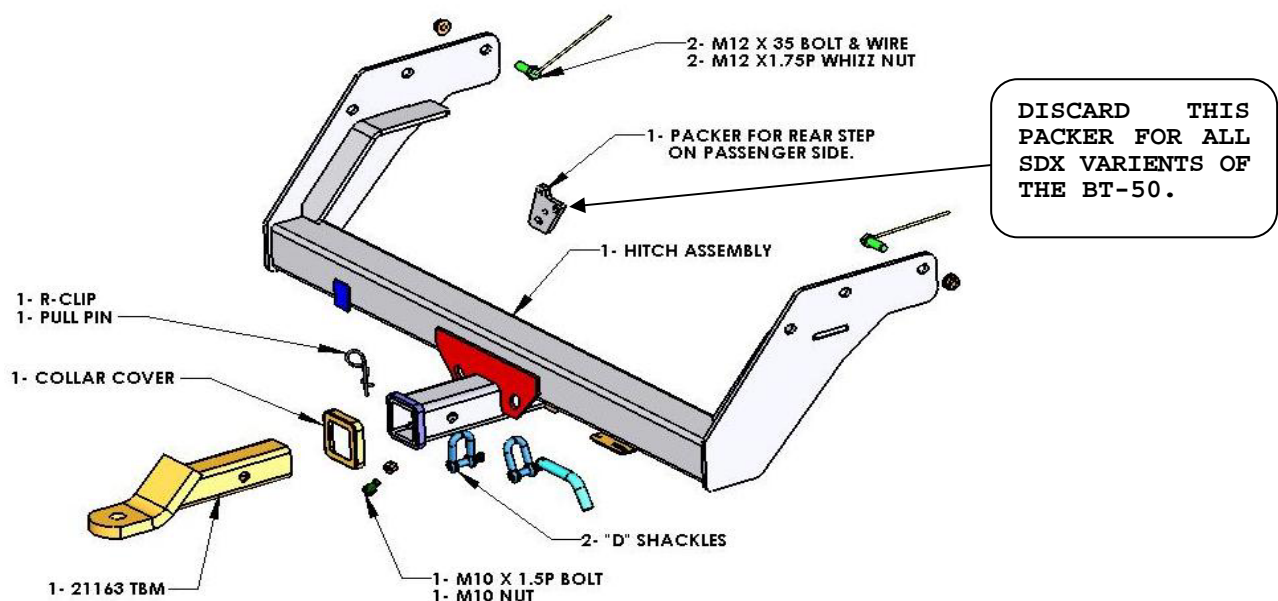

INSTALLATION INSTRUCTIONS

8313- FIT KIT TO SUIT MAZDA BT-50 SDX TUB BODY VARIENTS 07-ON

NOTE: FITS IN CONJUNCTION WITH BT-50 TOWBARS HAVING BUMPER STEP

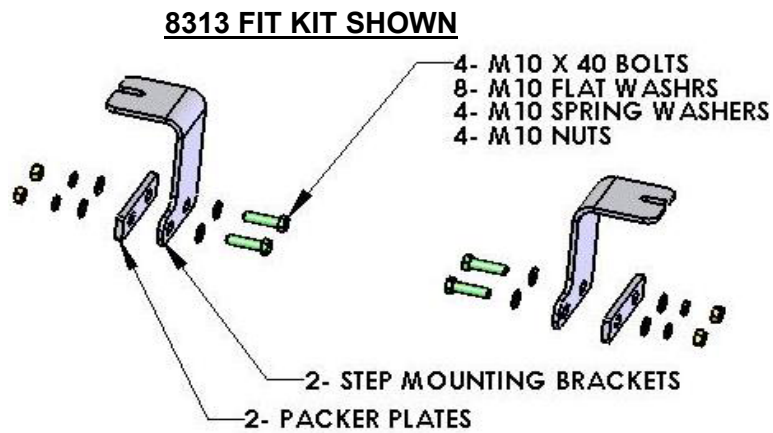

FIG 1: SHOWS SIDE ARM OF REAR BUMPER STEP FITTED TO CHASSIS



FIG 2: SHOWS BOLT HOLES THAT NEED TO BE SLOTTED.



INSTALLATION INSTRUCTIONS

8313- FIT KIT TO SUIT MAZDA BT-50 SDX TUB BODY VARIENTS 07-ON

NOTE: FITS IN CONJUNCTION WITH BT-50 TOWBARS HAVING BUMPER STEP

FIG 3: SHOWS THE BRACKET THAT SHOULD BE REMOVED FROM PASSENGER SIDE ARM OF BUMPER BAR.



FIG 4: SHOWS THE MOUNTING BRACKET FOR THE STEP THAT NEEDS TO BE DISCARDED & REPLACED WITH THE MOUNTING BRACKET PROVIDED IN THE KIT, ON BOTH SIDES OF THE STEP.



FIG 5: SHOWS THE MOUNTING BRACKETS & PACKER PLATES PROVIDED BEING FITTED ON THE STEP

