

TRAILBOSS

Towbar Fitting Instructions To Suit **BMW F30 3SERIES 2012 ON** Part Number **BM6L** Rating **1450/75 kg**

PLACE THESE INSTRUCTIONS IN THE VEHICLE'S GLOVEBOX AFTER INSTALLATION IS COMPLETE

WARNING:

1. Do not, drill, cut, weld or otherwise modify the tow bar.
2. If you are using electric welding on a motor vehicle, **always** check that the vehicle is not equipped with electronic engine or instrument management equipment. Failure to do so could **destroy** any onboard computers. If in doubt, check with the vehicle's manufacturer.
3. The high tensile fasteners supplied with this product were used to achieve the specified rating. If replacement is required ensure that fasteners of the same rating & quality are used. Contact an authorised **Trailboss** dealer if further information is required.

General:

1. Ensure all hardware items have been included refer to assembly diagram.
2. It is recommended that the instructions are read through and completely understood before making any attempt to fit this product.
3. Be wary of any changes to vehicle designs or other accessories that may conflict with the installation of this product.
4. Before drilling ensure that the area is clear of fuel, electrical & other components.
5. All holes drilled into the body panels shall have all burrs & swarf removed then coated with a suitable rust preventative paint.
6. For vehicles that require the bumper to be cut. Ensure cut out area is in correct position on the vehicle prior to cutting the bumper.
7. The high tensile fasteners supplied with this product were used to achieve the specified rating. If replacement is required ensure that fasteners of the same rating & quality are used. Contact an authorized **Trailboss** dealer if further information is required.
8. Ensure that all hardware is fastened to torque list below check fasteners on regular basis.
9. Tow bar load rating sticker provided with this product shall be conspicuously located on inside rear end of the driver's door. **(See diagram below)**.
10. Trailboss recommends that you check your tow ball to ensure that it complies with the Australian standards **AS 4177.2**.
11. **PLEASE NOTE:** It is advised to remove your lug or tbm when not actually towing so as to produce a clear view of the vehicles registration plate if obscured, and to also provide maximum available departure angle
12. Pull Pin must be fit in down position.

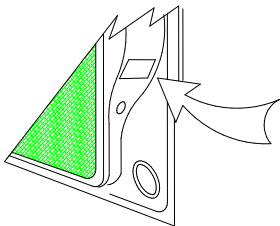

Place load rating sticker
inside driver's door here

FOR TRAILER TOWING PURPOSES ONLY
For towing capacity details please refer to vehicle owner's manual or to the manufacturer. Overloading can void your warranties.

RECOMMENDED ASSEMBLY TORQUE LISTING

<u>Diameter</u>	<u>Grade 8.8 Bolt</u>
M6	9.5 Nm
M8	21.7 Nm
M10	43.4 Nm
M12	77.3Nm
M14	146 Nm
M16	189.8 Nm

Tow bar Maintenance and Care.

Trailboss recommends that bolt torque's, as listed below, are routinely and regularly inspected and checked for correct tension. Replace any worn or defective parts.

We recommended to remove Tow Ball Mounts (TBM's, tongues or lugs) when not being used for any considerable length of time.

So as to avoid injury, when not towing it is suggested that the tongue, Pull Pin and R-clip are removed then stored in a safe, clean and dry place, away from excessive moisture.

Hitch Pull Pins and spring "R" clips are regularly checked for proper installation. Replace any worn or defective parts.

TRAILBOSS

Towbar Fitting Instructions
 To Suit **BMW F30 3SERIES 2012 ON**
 Part Number **BM6L**
 Rating **1450/75 kg**

PLACE THESE INSTRUCTIONS IN THE VEHICLE'S GLOVEBOX AFTER INSTALLATION IS COMPLETE

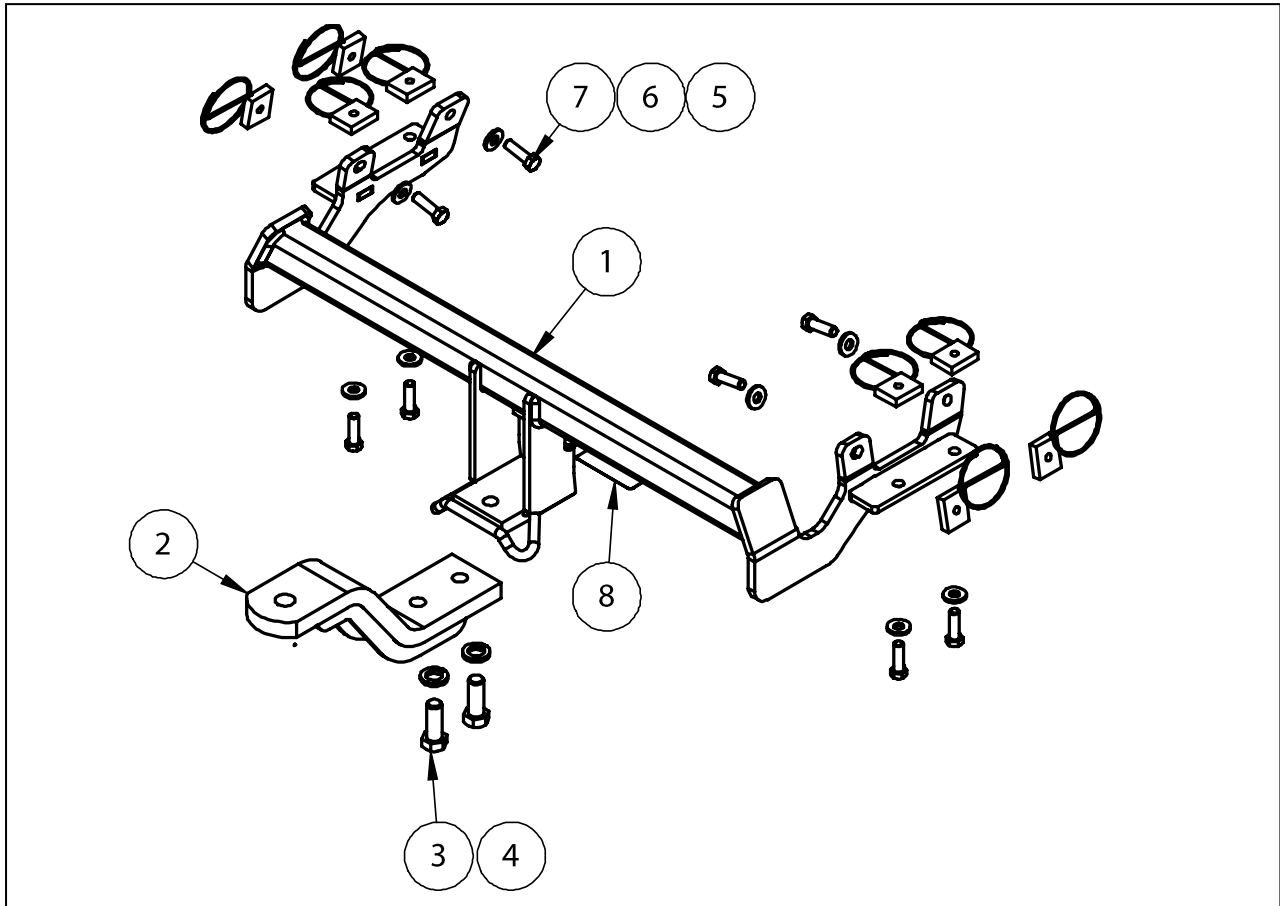

QTY.	DESCRIPTION	ITEM NO.
1	WELDED ASSEMBLY	1
1	LUG ASSY	2
2	M16x45.20P BOLT	3
2	M16x5x3.5 SPRING WASHER	4
8	TAPPED PLATE AND WIRE	5
8	WASHER FT M10x25.4x3	6
8	M10-1.5x35mm SET SCREW	7
1	ACRYLIC CP LABEL	8

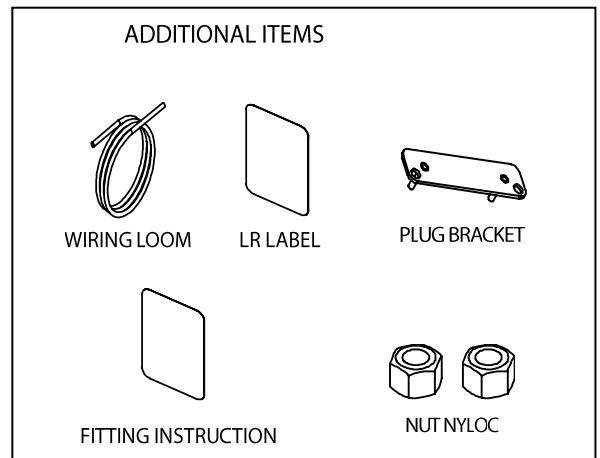



Towbar Fitting Instructions
To Suit **BMW F30 3SERIES 2012 ON**
Part Number **BM6L**
Rating **1450/75 kg**

PLACE THESE INSTRUCTIONS IN THE VEHICLE'S GLOVEBOX AFTER INSTALLATION IS COMPLETE

INSTRUCTION:

1. Remove 2x Screws from inside Rear Wheel Arc and 1x Scrivet for both LH & RH side. Also remove 1x Screw from top of the Bumper inside the Wheel Arc behind the lining for both the LH & RH side.
2. Remove 20x Screws from the underside of the vehicle and remove the cover.
3. Remove 1x Plastic Screw from light cover and remove cover for both LH & RH side.
4. Remove 1x Screw from Bumper located under previously removed Light Cover. Firmly pull on Bumper to release from Clips.
5. Remove 4xNuts from the Impact Beam and remove Impact Beam. Drop Exhaust from Rubber Mountings and remove Heat Shielding.
6. Mark and drill a $\varnothing 12$ mm hole on the inside of the Chassis Rail for both the LH & RH side, position the hole 42mm from the bottom of the Cassis Rail and 56mm from the back face of the Chassis Rail (the face that the Impact Beam is bolted to).
7. Using the 2 drilled holes firmly Bolt the Towbar into position confirming that the Towbar is positioned correctly by measuring that the rear face of the Chassis Rail (where the Impact Beam is bolted to) is approximately 34mm away from the Towbar side arm edge for both the LH & RH side.

Use the firmly bolted in Towbar as a Template to mark the remaining 6 holes and drill them out using a $\varnothing 12$ mm drill bit.
8. Thread the remaining wired Tapped Plates through the back face of the Chassis Rail and tighten all Bolts to the Torque specifications provided and cut off the excess wire from the Tapped Plates.
9. Cut of the bottom inside mounting face of the Impact Beam for the LH & RH side using the template provided, rustproof the cuts and then remount the Impact Beam.
10. Create a cut on the underside cover cutting in between the rear most centre mounting points from the rear most face of the cover through the slat to the second opening.
11. Reassemble vehicle in reverse order to disassembly.



Towbar Fitting Instructions
To Suit **BMW F30 3SERIES 2012 ON**
Part Number **BM6L**
Rating **1450/75 kg**

PLACE THESE INSTRUCTIONS IN THE VEHICLE'S GLOVEBOX AFTER INSTALLATION IS COMPLETE

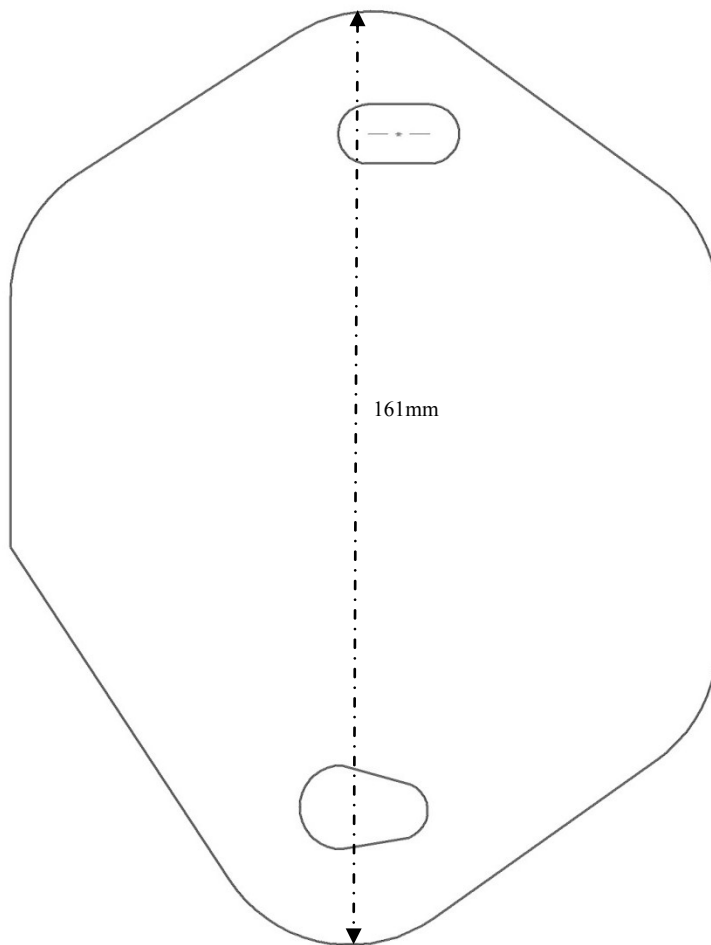

NOT TO SCALE



Wiring Loom Fitting Instructions
To Suit BMW 320D
Part Number 100902-WL

Wiring Loom Installation Instructions

BMW 320D
Part No: 100902-WL

Tail Harness Length Required: 1800mm

Wiring Loom Installation Time: Approx 20 Mins

TRAILBOSS

Wiring Loom Fitting Instructions To Suit BMW 320D Part Number 100902-WL

1. On the RHS of the luggage compartment, remove the access panel by turning the clip lock 90°.
2. In the RHS rear quarter panel, drill a Ø30mm hole (1).

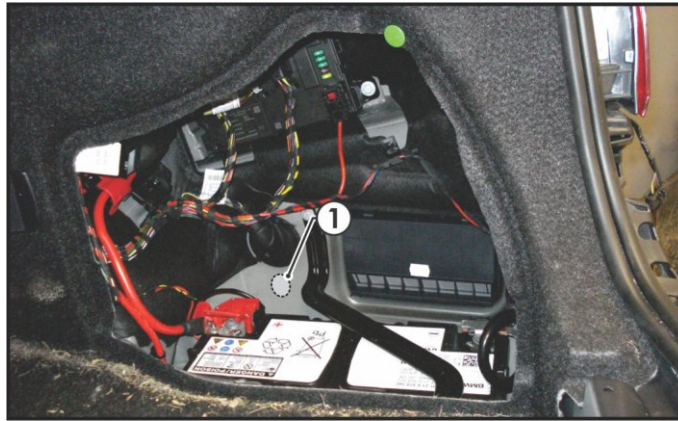

3. File any rough or sharp edges and spray with rust inhibitor.
4. Following the table below, connect the ezy-taps (1) to the corresponding vehicle wires (2), then connect the trailer patch terminal (3) to the ezy-taps (1).

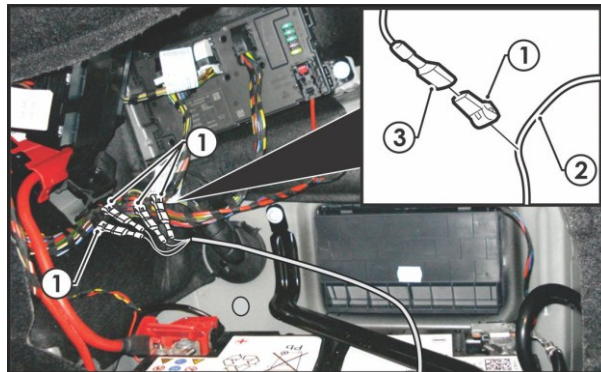

Function	Trailer Patch	Vehicle Connector
R.IND	GREEN / BLACK	BLACK / GREY
L.IND	YELLOW / BLACK	BLACK / WHITE
TAIL	BROWN / BLACK	GREY / YELLOW
BRAKES	RED / BLACK	BLACK / BLUE

Note: For the vehicle tail circuit, ensure to use the thicker GREY/YELLOW wire.

TRAILBOSS

Wiring Loom Fitting Instructions To Suit BMW 320D Part Number 100902-WL

5. Following the table below, connect the ezy-tap (1) to the vehicle's BLACK/BLUE wire (2), then connect the trailer patch terminal (3) to the ezy-tap (1).

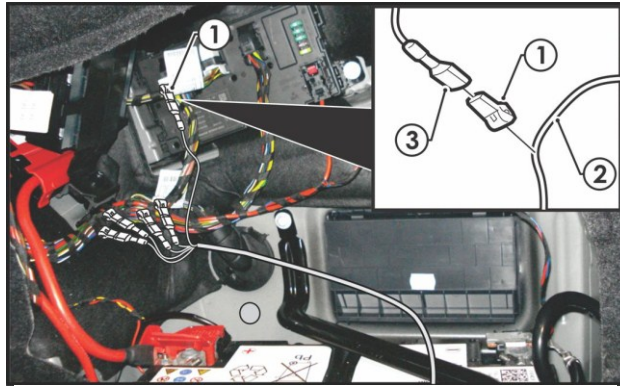

Function	Trailer Patch	Vehicle Connector
REVERSE	BLACK / WHITE	BLACK / BLUE

6. Connect the trailer patch ground ring terminal to the vehicle grounding point.
7. Connect the ORANGE wire, to the positive side of the vehicle battery.
8. Connect the trailer patch 12-way connector to the ECU (04838).
9. Apply double sided tape to the ECU (04838) and secure it to the vehicle sheet metal in a suitable location.

Note: Ensure the ECU connector is facing downwards.

10. Mount the trailer socket to the tow bar mounting bracket using M4 fasteners (not supplied).
11. Route the tail harness across the two bar towards the RHS of the vehicle and up through the previously drilled hole.
12. Ensure the tail harness grommet is seated correctly and secure in place using a cable tie (not supplied).
13. Connect the tail harness 8-way connector to the trailer wiring harness mating 8-way connector.
14. Test the trailer wiring harness function using a light board or multimeter.
15. Secure all harnesses using cable ties (not supplied).
16. Re-fit all removed parts and secure all fasteners, ensuring there are no squeaks or rattles.
17. Place the fitting instructions in the glove box after fitment.