



Towbar Fitting Instructions  
To Suit  
MITSUBISHI MAGNA SEDAN 4/96-9/05  
Part Number CL76  
Rating 1500Kg

1. Ensure all hardware items have been included.
2. Remove rear bumper bar.
- 2a. Remove top bolt holding plastic trim at each wheel arch. Pull towards centre of vehicle to expose screw in top forward portion of bumper, remove.
- 2b. Remove six plastic trim buttons from under side of bumper.
- 2c. Remove muffler from three rubber hangers.
- 2d. From under vehicle remove and discard four bumper arm mounting bolts from sub frame (two a side).
- 2e. Remove muffler heat shield.
- 2f. Remove rear plastic panel and material trim. Remove plastic trim buttons and screws from behind lights and ¼ panel trims and pull forward.
- 2g. Remove 12 6mm nuts and bolts from inside boot and remove bumper.
3. Cut bumper as per sketch provided. Models 4/96 to 6/03.
4. Hold towbar up to bottom of sub frames to align holes in towbar with holes in sub frames and support.
5. Fit bolts on plates down end of sub frame and fit through holes inside of sub frame and towbar. Fit nuts, washers, etc. as per sketch semi tight.
6. Refit bumper to vehicle using bolts, washers, etc. supplied as per sketch in reverse of step 2d.
7. Tighten all bolts to torque listing below.
8. Refit bumper bolts etc. in reverse of step 2.

**RECOMMENDED ASSEMBLY TORQUE LISTING**

<b><u>Diameter</u></b>	<b><u>Grade 8.8 Bolt</u></b>
	<b>Nm</b>
M6	9.5
M8	21.7
M10	43.4
M12	77.3
M14	121.0
M16	189.8

# TRAILBOSS

Towbar Fitting Instructions  
To Suit  
MITSUBISHI MAGNA SEDAN 4/96-9/05  
Part Number CL76  
Rating 1500Kg

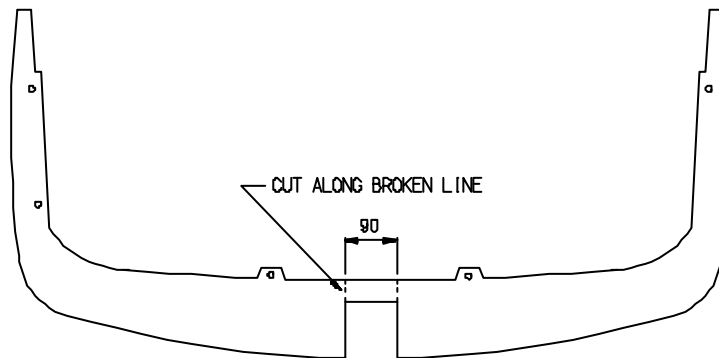
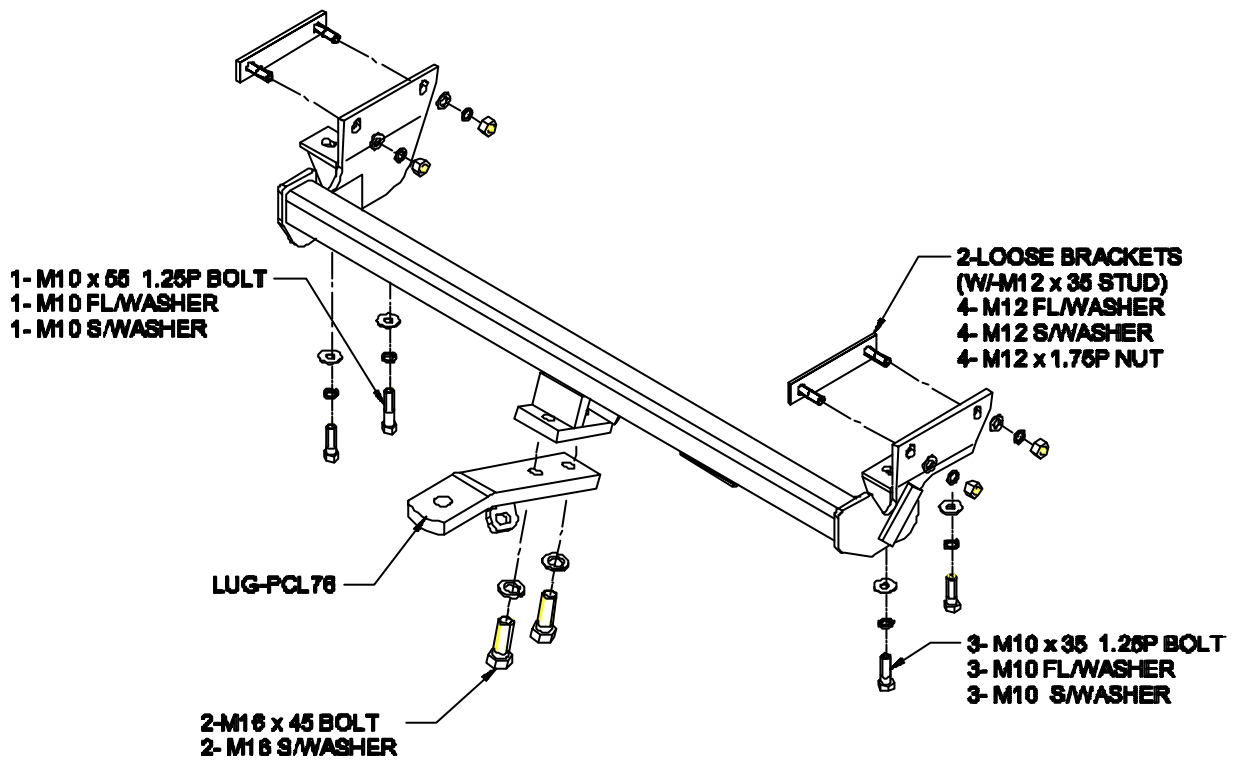

MITSUBISHI MAGNA SEDAN 4/96 - 9/05