



Towbar Fitting Instructions
TO SUIT FORD FIESTA 3 AND 5 DOOR HATCH 01-2006
Part Number FD125
Rating 900Kg

WARNING:

1. Do not, drill, cut, weld or otherwise modify the tow bar.
2. If you are using electric welding on a motor vehicle, **always** check that the vehicle is not equipped with electronic engine or instrument management equipment. Failure to do so could **destroy** any onboard computers. If in doubt, check with the vehicle's manufacturer.

1. Ensure all hardware has been included
2. Remove rear bumper via
 - a) Remove trim buttons from inside wheel arches (2 per side)
 - b) Remove 8mm hex screw from inside wheel arch, in behind arch trim (1 per side)
 - c) Remove trim buttons from bottom of bumper
 - d) Drill out rivets from top of bumper
 - e) Flex bumper out from the sides and pull rearward
3. Remove rear wheel liner clips to gain access to side rails and discard clips
4. Locate towbar into the chassis rails and fasten with 4 x M12 flat washers, spring washers and bolts
5. Tighten all bolts to torque listing below.
6. Cut bumper as per drawing as shown in Figure 1
7. Refit bumper bar in reverse of step 2 with the exception of step d), where in this case, the bumper is riveted with the supplied rivets.
8. Towbar rating sticker to be conspicuously located on inside rear end of the driver's door. (**See diagram below**)

RECOMMENDED ASSEMBLY TORQUE LISTING

Diameter	Grade 8.8 Bolt
	Nm
M6	9.5
M8	21.7
M10	43.4
M12	77.3
M16	189.8

FOR TOWING PURPOSES ONLY
For towing capacity details please refer to vehicle owner's manual or to the manufacturer. Overloading can void your warranties.

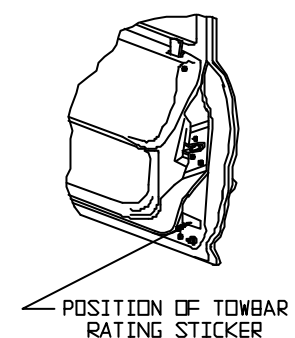

Towbar Fitting Instructions
TO SUIT FORD FIESTA 3 AND 5 DOOR HATCH 01-2006
Part Number FD125
Rating 900Kg

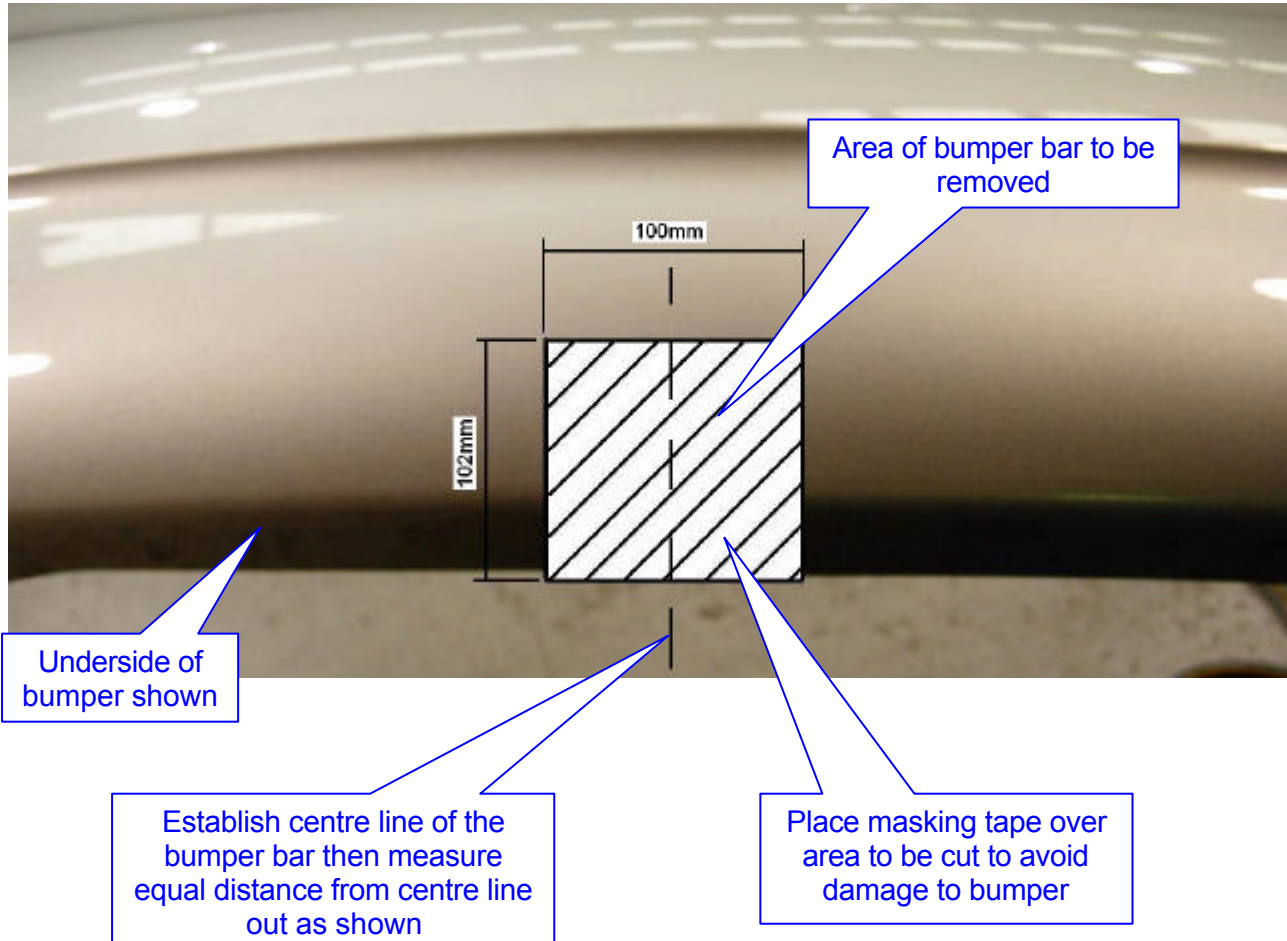
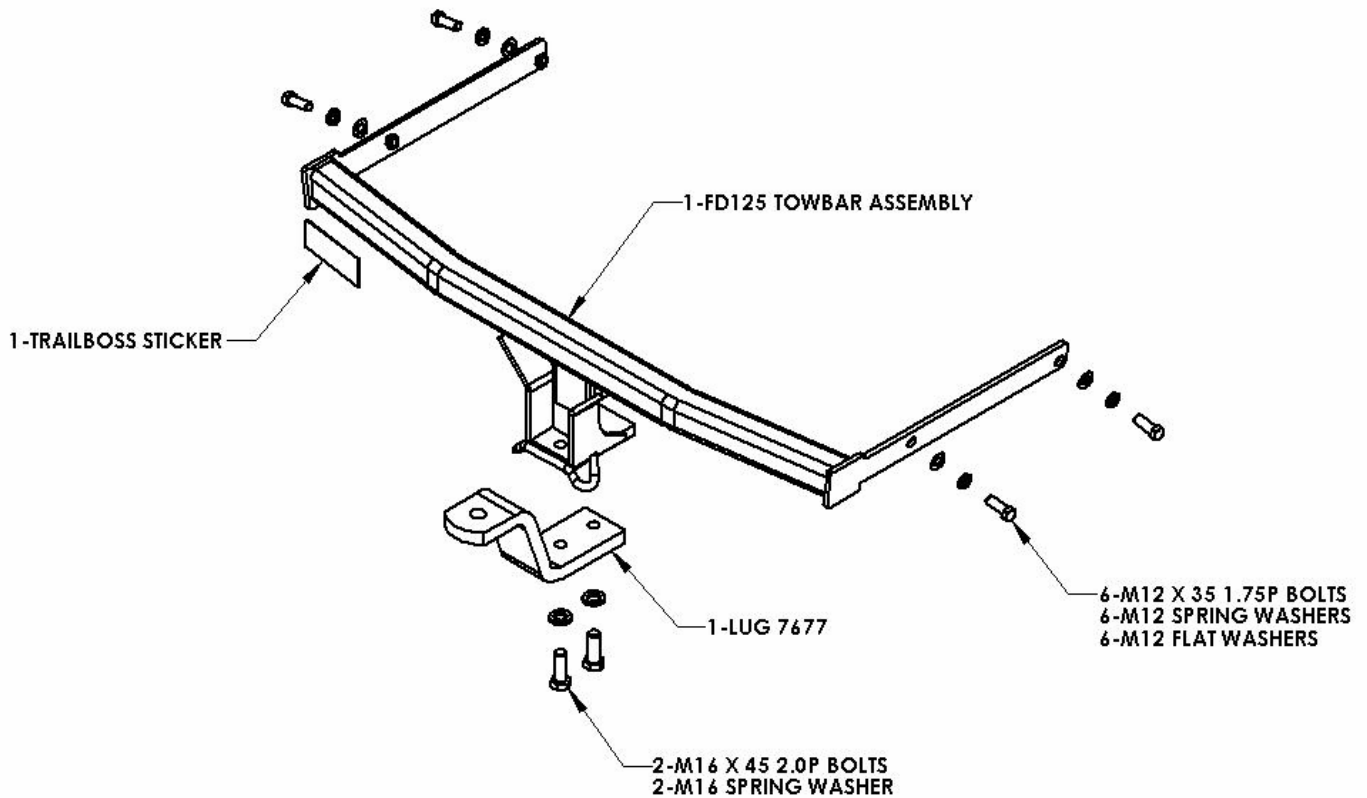

Figure-1 Location of bumper cut



Towbar Fitting Instructions
TO SUIT FORD FIESTA 3 AND 5 DOOR HATCH 01-2006
Part Number FD125
Rating 900Kg



PLEASE NOTE: You must remove the lug unless you are actually towing if it obscures your number plate. Failure to do so may result in a fine.