

TRAILBOSS

Tow bar Fitting Instructions To Suit Ford BA, BF Falcon Sedan & Fairlane Including XR6, XR8 Part Number FD131L Rating 1600 Kg Max Static Ball Load 160Kg

WARNING:

1. Do not, drill, cut, weld or otherwise modify the tow bar.
2. If you are using electric welding on a motor vehicle, **always** check that the vehicle is not equipped with electronic engine or instrument management equipment. Failure to do so could **destroy** any onboard computers. If in doubt, check with the vehicle's manufacturer.

General:

1. Ensure all hardware items have been included refer to assembly diagram.
2. It is recommended that the instructions are read through and completely understood before making any attempt to fit this product.
3. Be wary of any changes to vehicle designs or other accessories that may conflict with the installation of this product.
4. Before drilling ensure that the area is clear of fuel, electrical & other components.
5. All holes drilled into the body panels shall have all burrs & swarf removed then coated with a suitable rust preventative paint.
6. The high tensile fasteners supplied with this product were used to achieve the specified rating. If replacement is required ensure that fasteners of the same rating & quality are used. Contact an authorized **Trailboss** dealer if further information is required.
7. Ensure that all hardware is fastened to torque list below check fasteners on regular basis.
8. Tow bar load rating sticker provided with this product shall be conspicuously located on inside rear end of the driver's door. **(See diagram below).**
9. Trailboss recommends that you check your tow ball to ensure that it complies with the Australian standards **AS 4177.2**.
10. **PLEASE NOTE:** It is advised to remove your lug or tbn when not actually towing so as to produce a clear view of the vehicles registration plate if obscured, and to also provide maximum available departure angle

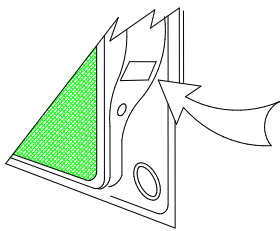

Place load rating sticker
inside driver's door here

FOR TOWING PURPOSES ONLY

For towing capacity details please refer to vehicle owner's manual or to the manufacturer. Overloading can void your warranties.

RECOMMENDED ASSEMBLY TORQUE LISTING

<u>Diameter</u>	<u>Grade 8.8 Bolt</u>
M6	9.5 Nm
M8	21.7 Nm
M10	43.4 Nm
M12	77.3 Nm
M16	189.8 Nm

Tow bar Maintenance and Care.

Trailboss recommends that bolt torque's, as listed below, are routinely and regularly inspected and checked for correct tension. Replace any worn or defective parts.

We recommended to remove Tow Ball Mounts (TBM's, tongues or lugs) when not being used for any considerable length of time.

So as to avoid injury, when not towing it is suggested that the tongue, Pull Pin and R-clip are removed then stored in a safe, clean and dry place, away from excessive moisture.

Hitch Pull Pins and spring "R" clips are regularly checked for proper installation. Replace any worn or defective parts.

TRAILBOSS

Tow bar Fitting Instructions To Suit Ford BA, BF Falcon Sedan & Fairlane Including XR6, XR8 Part Number FD131L Rating 1600 Kg Max Static Ball Load 160Kg

a) Remove bumper via

- b) Remove 3 plastic trim buttons and 1 self-taping screw from each wheel arch.
- c) Remove 3 plastic trim buttons from spear wheel well.
- d) Remove plastic trim buttons from rear ¼ trim and fold forward.
- e) Remove 4 x 5mm nuts from below tail light assemblies.
- f) Flex bumper bar out at the sides then pull rearward to remove some force may be required.
- g) Offer tow bar to the vehicle sub frame then fasten with driver side vertical mount with taptite bolt provided see fig 6.
- h) Fasten passenger side horizontal mounts with taptite bolts provided see fig 7.
- i) Using holes on driver's side plate as a guide drill pilot holes first then drill through 12.5mm see fig 8.
- j) Fit M 12 x 35 bolts flat & spring washers provided ensure that packer plate is fitted between side plate of tow bar & end of chassis mount see assembly detail for correct orientation of components.
- k) **Drill centre holes via**
- l) Using the holes in the tow bar as a guide first pilot drill then drill out 11mm in two places see fig 9.
- m) Fit two bolt & loose plates on wire through access points on the rear panel of the vehicle so that bolt drop down through the holes just drilled through the panel.
- n) Fasten with M10 whizz nuts provided fasten to torque listing.
- o) Ensure that the wire on bolts is inside the chassis panel and not sticking out.
- p) Using diagram supplied mark and drill hole in bumper suitable for socket to tighten tongue bolts
- q) Refit bumper in reverse of step f through to step a.

Bumper detail for BA & BF models drill 35mm hole as shown so that tow lug can be installed & removed from vehicle.

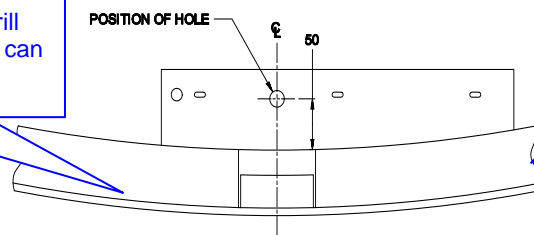

Representation of underside of bumper bar skin

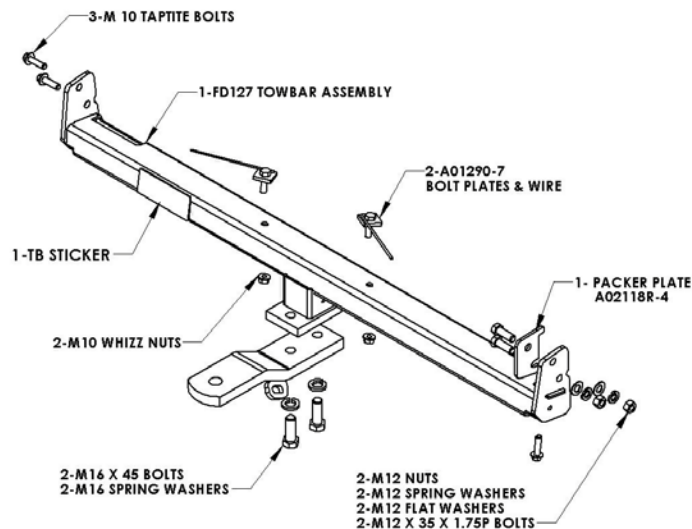



Wiring Loom Fitting Instructions
To Suit Ford
BA/BF Falcon Sedan
Wagon AU123 BA (Sept onwards)
Falcon AU Sedan (Sept 1998 to Aug 2002)
BA/BF/XR6/Xr8 Sedan
AU Falcon Sedan (Sept 1998 to Sept 2002)
Territory
Part Number 100001-WL

Wiring Loom Installation Instructions

Ford
Part No: 100001-WL

Tail Harness Length Required: 1200mm
RPA Override Switch Part No: 04848 (If Fitted)

Wiring Loom Installation Time: Approx 10 - 40 Mins depending on
vehicle model.



Wiring Loom Fitting Instructions
To Suit Ford
BA/BF Falcon Sedan
Wagon AU123 BA (Sept onwards)
Falcon AU Sedan (Sept 1998 to Aug 2002)
BA/BF/XR6/Xr8 Sedan
AU Falcon Sedan (Sept 1998 to Sept 2002)
Territory
Part Number 100001-WL

Sedan Steps:

1. In the luggage compartment, remove the necessary trims to gain access to the RHS tail lights.
2. Connect the Trailer Patch Harness (P/No: 100001-WL) connector to the vehicle break out connector.

BA/BF Sedan models only:

3. At the RHS rear quarter of the vehicle, remove the vehicle grommet.
4. From outside of the vehicle, route in the Tail Harness (length 1200mm) through the grommet hole and connect it to the Trailer Patch Harness connector. **Note: If vehicle is fitted with an RPA kit, drill a Ø30mm access hole near the existing grommet for Tail Harness routing.**
5. Route the Tail Harness socket towards the towbar mounting bracket.
6. Secure the Tail Harness socket onto the towbar mounting bracket using M4 fasteners.

AU Sedan models only:

7. Locate the RHS grommet near the spare wheel well.
8. Mount the Trailer Socket to the towbar using M4 Fasteners then route the Tail Harness (length 1200mm) over to the grommet hole then feed it into the vehicle.
9. From underneath the vehicle, route the Tail Harness (tail length 1800mm) into the vehicle. Slide the grommet to the desired position and then cable tie inside the vehicle. Press the grommet in place, ensuring a good seal is obtained. Then secure the grommet in place with a cable tie (not supplied).
10. In the luggage compartment, connect the Tail Harness to the Trailer Harness Patch.

Test the Tail Harness socket using a light board or multimeter.

11. Secure all harnesses using cables ties.
12. Refit all removed parts and secure all fasteners ensuring there are no squeaks or rattles.
13. Place instructions in glove box after fitment.

Wagon models only:

14. On the RHS trim remove the Jack Access panel and locate the 8-way trailer breakout connector.



Wiring Loom Fitting Instructions
To Suit Ford
BA/BF Falcon Sedan
Wagon AU123 BA (Sept onwards)
Falcon AU Sedan (Sept 1998 to Aug 2002)
BA/BF/XR6/Xr8 Sedan
AU Falcon Sedan (Sept 1998 to Sept 2002)
Territory
Part Number 100001-WL

15. Plug the Trailer Harness Patch (P/N 100001-WL) to the 8-way trailer breakout connector.
 16. In the jack access cavity area, remove the grommet blanking plug from the RHS rear quarter.
 17. Outside, at the rear of the vehicle, mount the Trailer Socket to the towbar using M4 fasteners.
 18. From underneath the vehicle, route the Tail Harness (length 1200mm) over to the grommet hole then feed it through the grommet hole and into the vehicle. **Note: The grommet must be moved along the harness to the desired location.**
 19. Press the grommet in place, ensuring a good seal is obtained. Then secure the grommet in place with a cable tie (not supplied).
 20. Inside the vehicle, connect the Tail Harness connector to the trailer patch. Cable Tie back any excess length.
 21. Test the Trailer socket using a light board or multi-meter.
 22. Secure the all harnesses using cables ties.
 23. Refit all removed parts and secure all fasteners.
 24. Place instructions in glove box after fitment.
- Territory models only:**
25. Remove the necessary trims to gain access to the RHS vehicle 8-way break out connector then connect the Trailer Patch harness (P/No: 100001-WL) to the break-out connector.
 26. On the RHS rear, below the tail light, remove the grommet and feed the Tail Harness (Length 1200mm) through the hole until it comes through the inner cavity.
 27. Connect the Trailer Patch Harness to the Tail Harness.
 28. On the outside rear of the vehicle, secure the trailer socket onto towbar mounting plate using M4 fasteners.
 29. Test the Trailer socket using a light board or multi-meter.
 30. Secure the all harnesses using cables ties.
 31. Refit all removed parts and secure all fasteners.
 32. Place instructions in glove box after fitment.