

TRAILBOSS

Towbar Fitting Instructions To Suit **HONDA JAZZ 2014** Part Number **HN70L** Rating **1000/45 kg**

PLACE THESE INSTRUCTIONS IN THE VEHICLE'S GLOVEBOX AFTER INSTALLATION IS COMPLETED

WARNING:

1. Do not, drill, cut, weld or otherwise modify the tow bar.
2. If you are using electric welding on a motor vehicle, **always** check that the vehicle is not equipped with electronic engine or instrument management equipment. Failure to do so could **destroy** any onboard computers. If in doubt, check with the vehicle's manufacturer.
3. The high tensile fasteners supplied with this product were used to achieve the specified rating. If replacement is required ensure that fasteners of the same rating & quality are used. Contact an authorised **Trailboss** dealer if further information is required.
4. If TBM is used in inverted position tow ball may make contact with rear tailgate when lowered, which could cause damage.

General:

1. Ensure all hardware items have been included refer to assembly diagram.
2. It is recommended that the instructions are read through and completely understood before making any attempt to fit this product.
3. Be wary of any changes to vehicle designs or other accessories that may conflict with the installation of this product.
4. Before drilling ensure that the area is clear of fuel, electrical & other components.
5. All holes drilled into the body panels shall have all burrs & swarf removed then coated with a suitable rust preventative paint.
6. For vehicles that require the bumper to be cut. Ensure cut out area is in correct position on the vehicle prior to cutting the bumper.
7. The high tensile fasteners supplied with this product were used to achieve the specified rating. If replacement is required ensure that fasteners of the same rating & quality are used. Contact an authorized **Trailboss** dealer if further information is required.
8. Ensure that all hardware is fastened to torque list below check fasteners on regular basis.
9. Tow bar load rating sticker provided with this product shall be conspicuously located on inside rear end of the driver's door. **(See diagram below).**
10. Trailboss recommends that you check your tow ball to ensure that it complies with the Australian standards **AS 4177.2.**
11. **PLEASE NOTE:** It is advised to remove your LUG or TBM when not actually towing so as to produce a clear view of the vehicles registration plate if obscured, and to also provide maximum available departure angle
12. Pull Pin must be fit in down position.

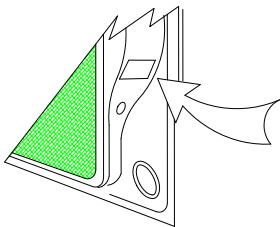

Place load rating sticker
inside driver's door here

FOR TRAILER TOWING PURPOSES ONLY
For towing capacity details please refer to vehicle owner's manual or to the manufacturer. Overloading can void your warranties.

RECOMMENDED ASSEMBLY TORQUE LISTING

Diameter	Grade 8.8 Bolt
M6	9.5 Nm
M8	21.7 Nm
M10	43.4 Nm
M12	77.3Nm
M14	146 Nm
M16	189.8 Nm

Tow bar Maintenance and Care.

Trailboss recommends that bolt torque's, as listed below, are routinely and regularly inspected and checked for correct tension. Replace any worn or defective parts.

We recommended to remove Tow Ball Mounts (TBM's, tongues or lugs) when not being used for any considerable length of time.

So as to avoid injury, when not towing it is suggested that the tongue, Pull Pin and R-clip are removed then stored in a safe, clean and dry place, away from excessive moisture.

Hitch Pull Pins and spring "R" clips are regularly checked for proper installation. Replace any worn or defective parts.

TRAILBOSS

Towbar Fitting Instructions
 To Suit **HONDA JAZZ 2014**
 Part Number **HN70L**
 Rating **1000/45 kg**

PLACE THESE INSTRUCTIONS IN THE VEHICLE'S GLOVEBOX AFTER INSTALLATION IS COMPLETED

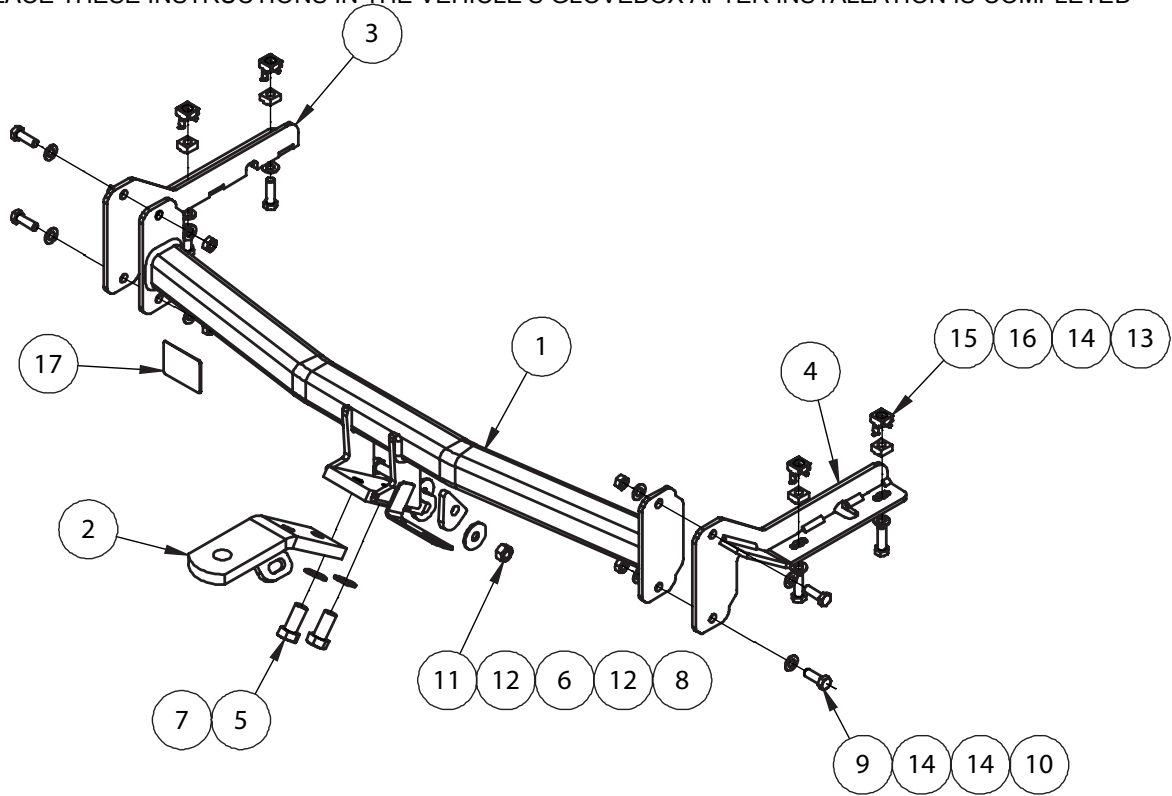

QTY.	DESCRIPTION	ITEM NO.
1	WELDED ASSY	1
1	LUG ASSY	2
1	LH SIDE ARM	3
1	RH SIDE ARM	4
2	BOLT ZP BLACK M16x40 2.0P	5
1	HOOK PLATE	6
2	FLAT WASHER M16	7
1	SET SCREW M12-1.25x50	8
4	SET SCREW M10-1.25x30	9
4	NUT HX M10-1.25 Z/P	10
1	HEX NUT M12x1.25 PC8	11
2	WASHER FLAT M12x37x3mm	12
4	BOLT M10-1.5x35 480HR	13
12	F/WASHER M10 21x1.6 480HR	14
4	NUT CAGE	15
4	CAGE NUT M10x1.5	16
1	ACRYLIC COMPLIANCE PLATE	17

ADDITIONAL ITEMS



WIRING LOOM



FITTING INSTRUCTION

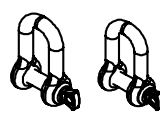

D SHACKLES



LR LABEL

TRAILBOSS

Towbar Fitting Instructions
To Suit **HONDA JAZZ 2014**
Part Number **HN70L**
Rating **1000/45 kg**

PLACE THESE INSTRUCTIONS IN THE VEHICLE'S GLOVEBOX AFTER INSTALLATION IS COMPLETED

1. Follow the steps below to remove the Rear Bumper.

- Remove four Bolts in the middle.
- Remove Clips from bottom.
- Remove self-tapping Screws from wheel house liner.
- Carefully pull away each corner of the Bumper and place Bumper on cardboard.
- Disconnect Wiring Harness for vehicle with rear park assist.

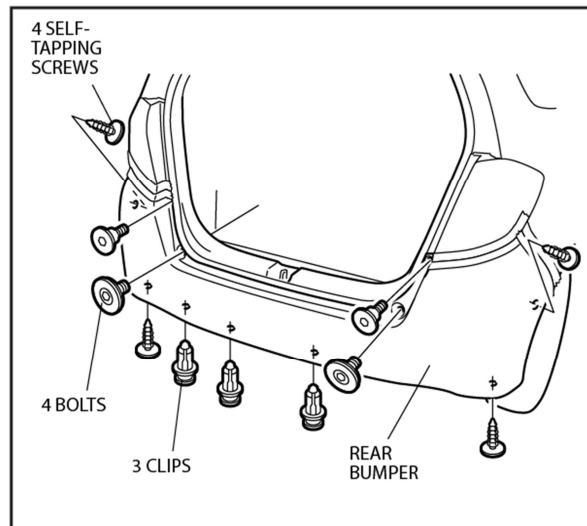

2. On LHS and RHS of rear Bumper panel, using a 5mm drill bit, drill out existing dimples. Using a Saw, cut out the panel along the perforated area and file away any burrs and edges.

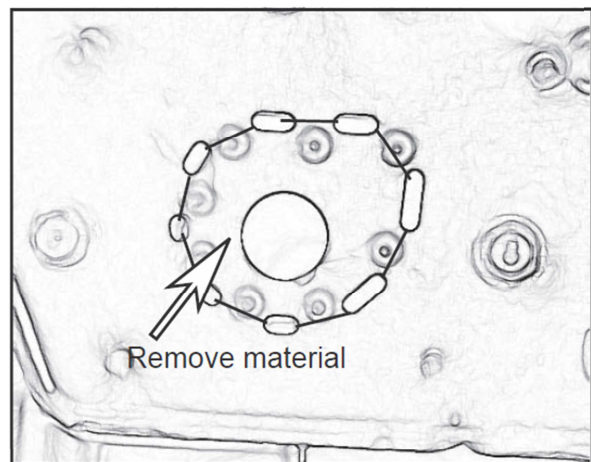

3. Disconnect Muffler from isolator mounting 2 places.

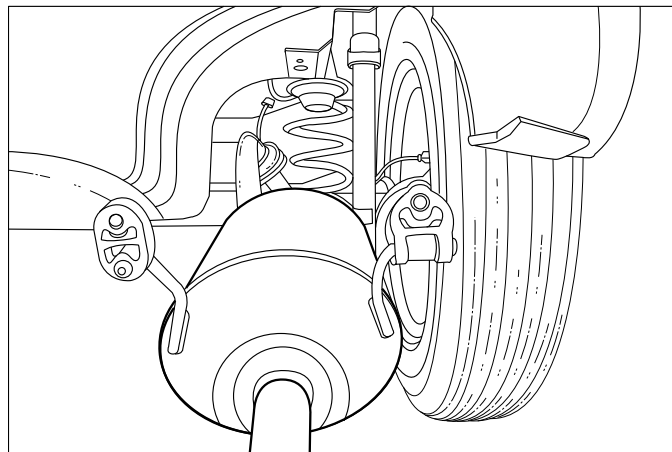

Towbar Fitting Instructions
To Suit **HONDA JAZZ 2014**
Part Number **HN70L**
Rating **1000/45 kg**

PLACE THESE INSTRUCTIONS IN THE VEHICLE'S GLOVEBOX AFTER INSTALLATION IS COMPLETED

4. Using template on page 8 (chassis rail hole), drill 12mm diameter hole on the both sides of vehicle.

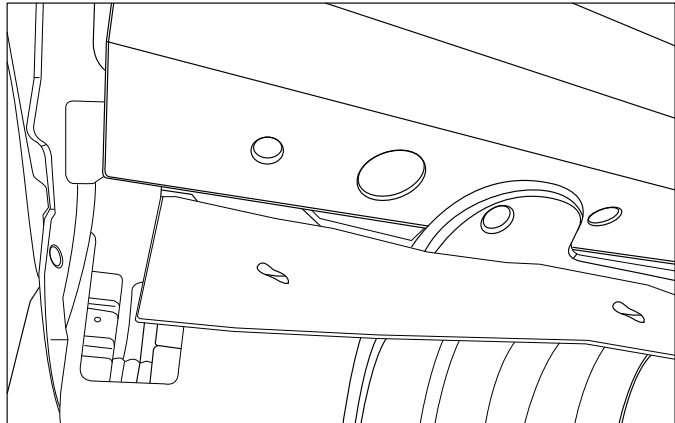

5. Insert Cage Nuts into side arms. Ensure tabs on nut align with slots in plate.

Then assembly side arms into Chassis rail holes and loosely fasten.

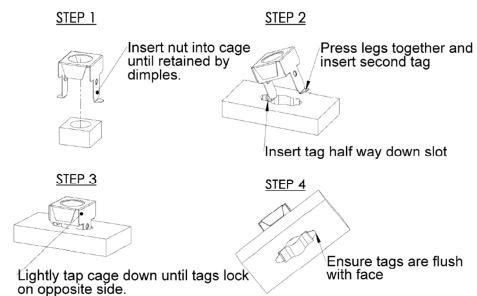

6. Assembly Cross tube to Side arms and fasten Cross tube to centre Tow Hook on vehicle using items shown in parts list.

Tighten all mounting bolts to the torques listed on page 2.

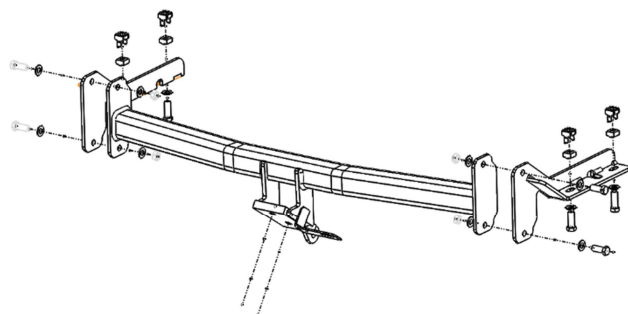



Towbar Fitting Instructions
To Suit **HONDA JAZZ 2014**
Part Number **HN70L**
Rating **1000/45 kg**

PLACE THESE INSTRUCTIONS IN THE VEHICLE'S GLOVEBOX AFTER INSTALLATION IS COMPLETED

7. Bumper Cut, refer to template on page 7.

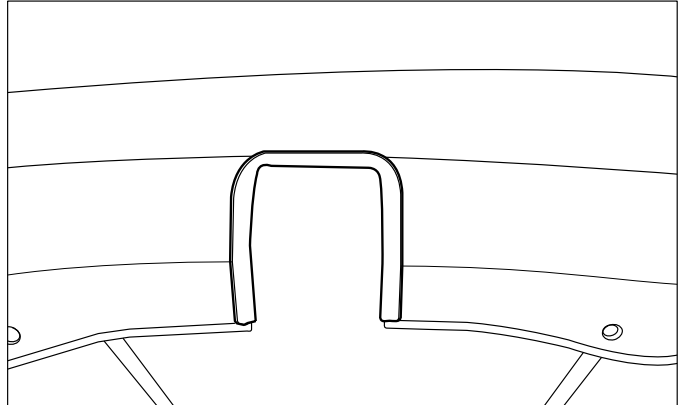

8. Reassembly vehicle in reverse order to the dissemble procedure.

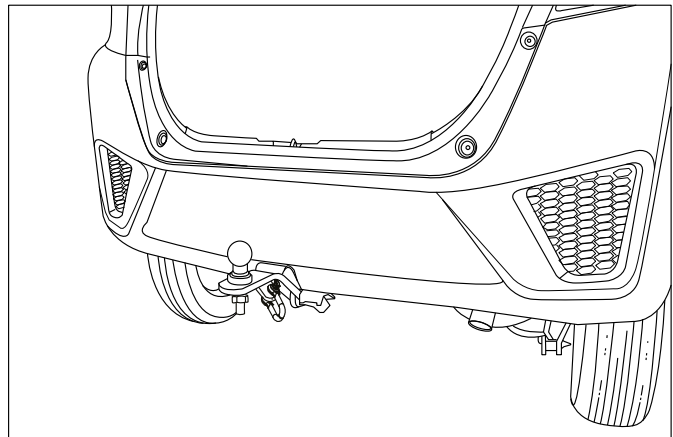



Towbar Fitting Instructions
To Suit **HONDA JAZZ 2014**
Part Number **HN70L**
Rating **1000/45 kg**

PLACE THESE INSTRUCTIONS IN THE VEHICLE'S GLOVEBOX AFTER INSTALLATION IS COMPLETED
Bumper Cut Template

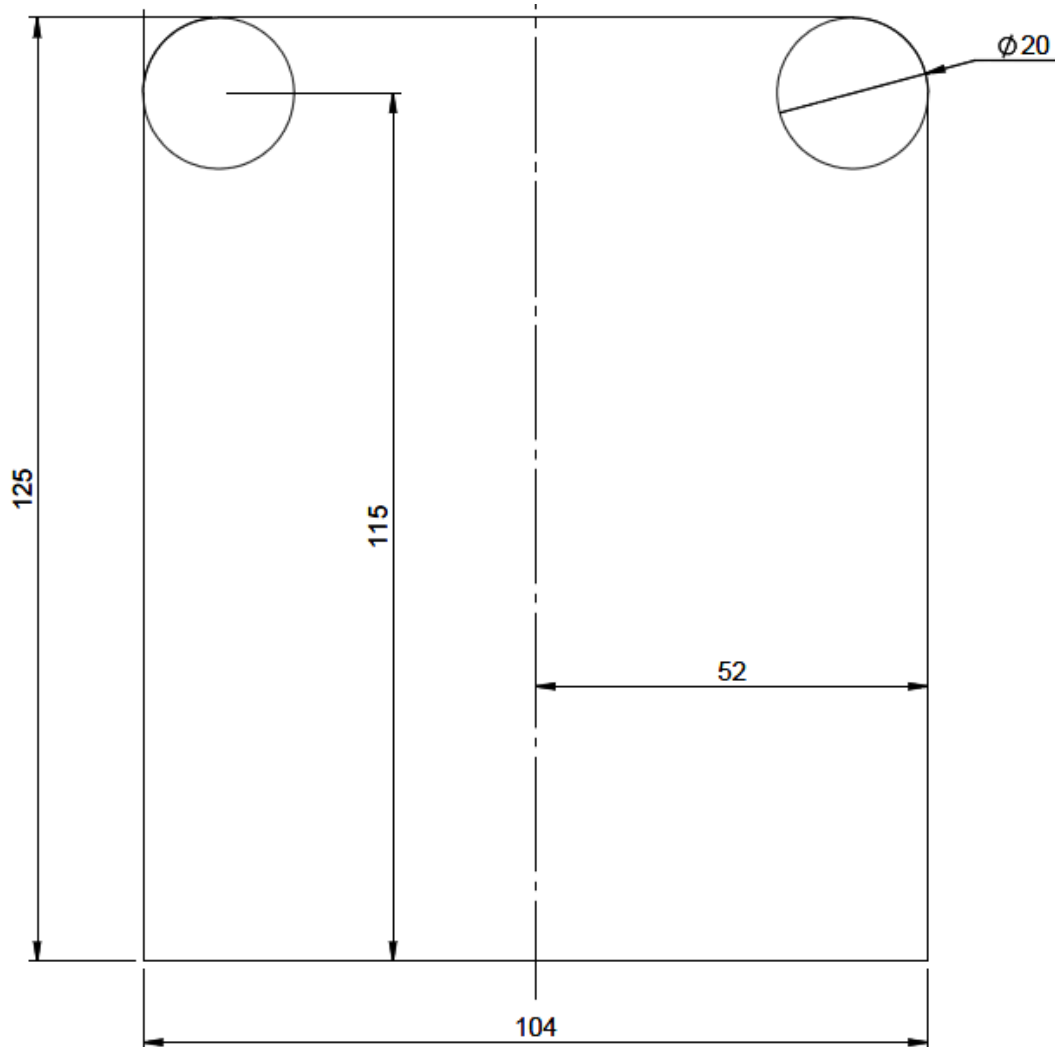

NOTE: Check that template is printed 1:1 scale



Towbar Fitting Instructions
To Suit **HONDA JAZZ 2014**
Part Number **HN70L**
Rating **1000/45 kg**

PLACE THESE INSTRUCTIONS IN THE VEHICLE'S GLOVEBOX AFTER INSTALLATION IS COMPLETED

Chassis Hole Template:

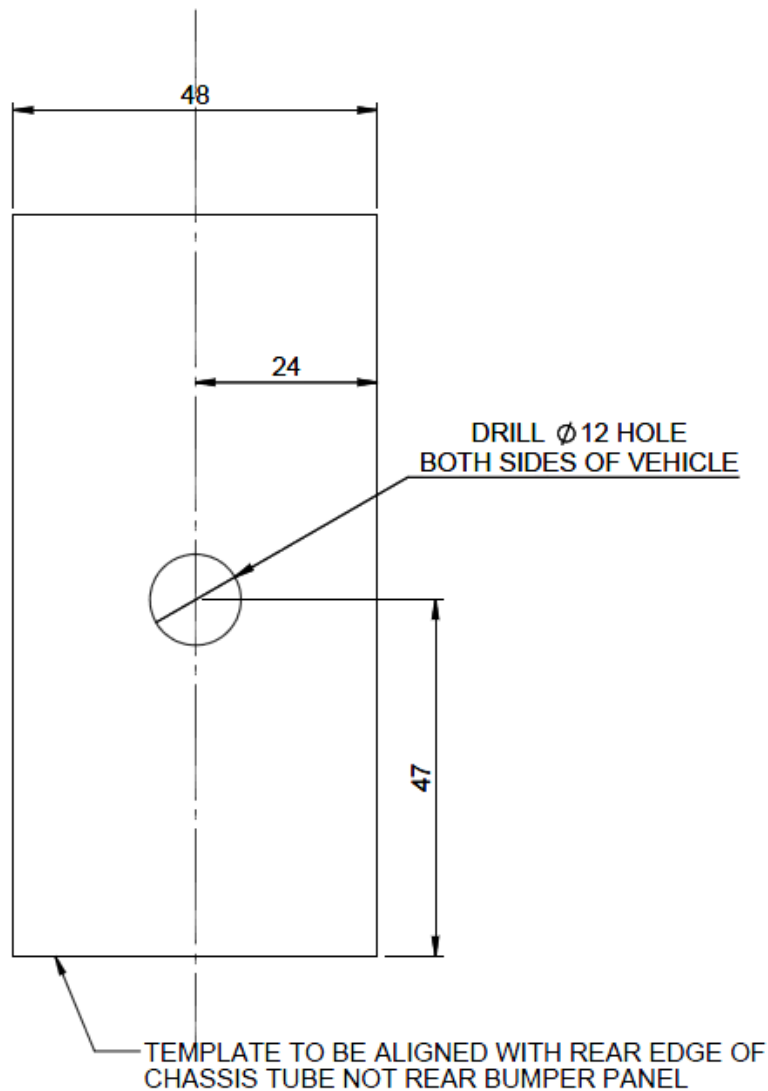

NOTE: Check that template is printed 1:1 scale



Wiring Loom Fitting Instructions
To Suit Honda Jazz
Part Number: 101195-WL

Wiring Loom Installation Instructions

Honda Jazz
Part No: 101195-WL

Tail Harness Length Required: 400mm

Wiring Loom Installation Time: Approx 20 Mins



Wiring Loom Fitting Instructions
To Suit Honda Jazz
Part Number: 101195-WL

1. Remove the RHS rear tail light assembly by removing the two fasteners. **Repeat for the LHS.**
2. Remove the rear bumper.
3. Connect the trailer patch (P/No: 101195-WL) LHS branch 2-way connectors in between the vehicle tail light assembly 2-way connectors and connect the trailer patch 3-way connectors in between the vehicle harness and tail light assembly 3-way connectors.
4. Route the trailer patch harness along the rear of the vehicle (towbar if already fitted) and connect the trailer patch RHS branch 2-way connector into the tail light assembly 2-way connector.
5. Secure the trailer patch harness ground ring terminal to the vehicle sheet metal at a suitable location using a tek screw (not supplied).
6. Mount the trailer socket to the tow bar mounting bracket using M4 fasteners (not supplied).
7. Route the tail harness (tail length 400mm) across the tow bar towards the LHS of the vehicle and towards the trailer patch 8-way connector.
8. Connect the tail harness 8-way connector to the trailer patch 8-way mating connector.
9. Waterproof the trailer patch 8-way connector and the tail harness 8-way male connector using silicone or grease.
10. Test the Trailer Harness function using a Light Board or multi-meter.
11. Secure all Harnesses using cables ties (not supplied).
12. Re-fit all removed parts and secure all fasteners, ensuring there are no squeaks or rattles.
13. Place the instructions in the glove box after fitment.