



Towbar Fitting Instructions
To Suit **HONDA CIVIC 10TH GEN CL2**
Part Number **HN71L**
Rating **800/50 kg**

PLACE THESE INSTRUCTIONS IN THE VEHICLE'S GLOVEBOX AFTER INSTALLATION IS COMPLETED

WARNING:

1. Do not, drill, cut, weld or otherwise modify the tow bar.
2. If you are using electric welding on a motor vehicle, **always** check that the vehicle is not equipped with electronic engine or instrument management equipment. Failure to do so could **destroy** any onboard computers. If in doubt, check with the vehicle's manufacturer.
3. The high tensile fasteners supplied with this product were used to achieve the specified rating. If replacement is required ensure that fasteners of the same rating & quality are used. Contact an authorised **Trailboss** dealer if further information is required.
4. If TBM is used in inverted position tow ball may make contact with rear tailgate when lowered, which could cause damage.

General:

1. Ensure all hardware items have been included refer to assembly diagram.
2. It is recommended that the instructions are read through and completely understood before making any attempt to fit this product.
3. Be wary of any changes to vehicle designs or other accessories that may conflict with the installation of this product.
4. Before drilling ensure that the area is clear of fuel, electrical & other components.
5. All holes drilled into the body panels shall have all burrs & swarf removed then coated with a suitable rust preventative paint.
6. For vehicles that require the bumper to be cut. Ensure cut out area is in correct position on the vehicle prior to cutting the bumper.
7. The high tensile fasteners supplied with this product were used to achieve the specified rating. If replacement is required ensure that fasteners of the same rating & quality are used. Contact an authorized **Trailboss** dealer if further information is required.
8. Ensure that all hardware is fastened to torque list below check fasteners on regular basis.
9. Tow bar load rating sticker provided with this product shall be conspicuously located on inside rear end of the driver's door. **(See diagram below).**
10. Trailboss recommends that you check your tow ball to ensure that it complies with the Australian standards **AS 4177.2.**
11. **PLEASE NOTE:** It is advised to remove your LUG or TBM when not actually towing so as to produce a clear view of the vehicles registration plate if obscured, and to also provide maximum available departure angle

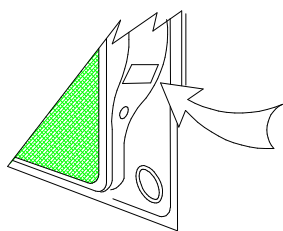

Place load rating sticker
inside driver's door here

FOR TRAILER TOWING PURPOSES ONLY
For towing capacity details please refer to vehicle owner's manual or to the manufacturer. Overloading can void your warranties.

RECOMMENDED ASSEMBLY TORQUE LISTING

Diameter	Grade 8.8 Bolt
M6	9.5 Nm
M8	21.7 Nm
M10	43.4 Nm
M12	77.3Nm
M14	146 Nm
M16	189.8 Nm

Tow bar Maintenance and Care.

Trailboss recommends that bolt torque's, as listed below, are routinely and regularly inspected and checked for correct tension. Replace any worn or defective parts.

We recommended to remove Tow Ball Mounts (TBM's, tongues or lugs) when not being used for any considerable length of time.

So as to avoid injury, when not towing it is suggested that the tongue, Pull Pin and R-clip are removed then stored in a safe, clean and dry place, away from excessive moisture.

Hitch Pull Pins and spring "R" clips are regularly checked for proper installation. Replace any worn or defective parts.

Cequent Customer Service
Ph: 1800 812 017 Fax: 03 9898 3299
Email: info@cequent.com.au
Post: PO Box 4050, Dandenong South VIC 3175

TRAILBOSS

Towbar Fitting Instructions
 To Suit **HONDA CIVIC 10TH GEN CL2**
 Part Number **HN71L**
 Rating **800/50 kg**

PLACE THESE INSTRUCTIONS IN THE VEHICLE'S GLOVEBOX AFTER INSTALLATION IS COMPLETED

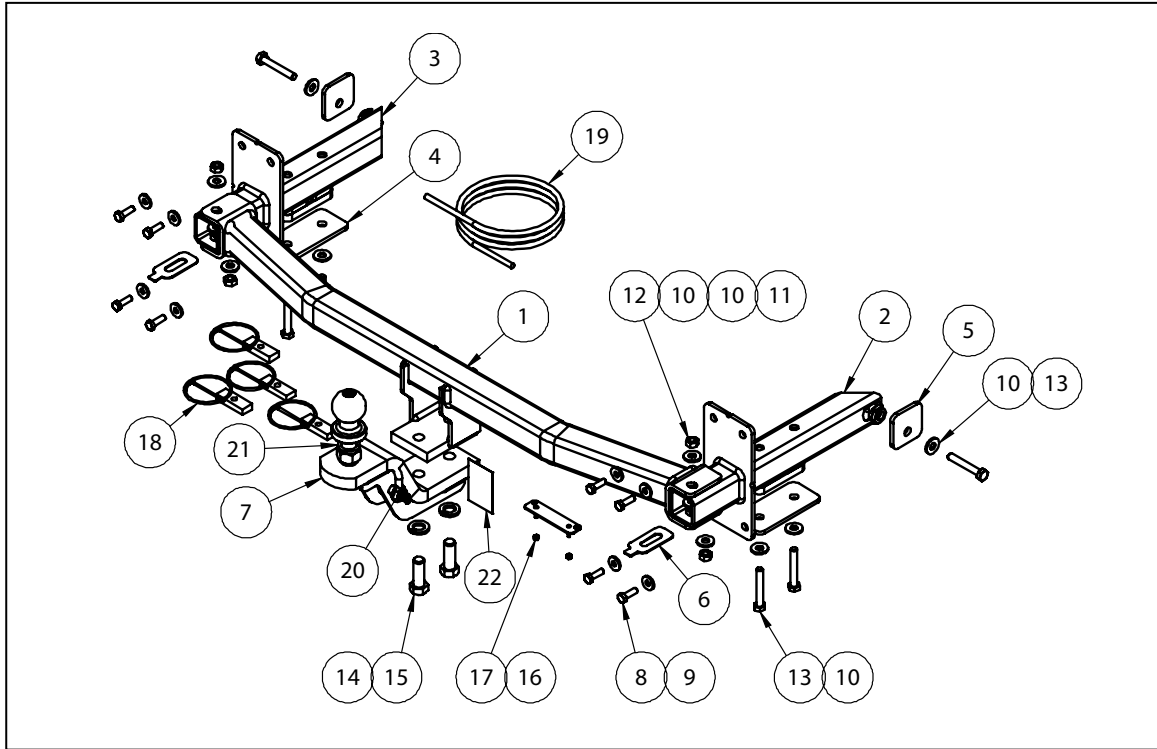

ITEM NO.	DESCRIPTION	QTY.
1	WELDED TOWBAR ASSEMBLY	1
2	RHS SIDEARMS / INSERT	1
3	LHS SIDEARMS / INSERT	1
4	WASHER PLATE DOUBLE HOLE	2
5	WASHER PLATE SINGLE HOLE	2
6	SHIM PLATE	2
7	LUG ASSY	1
8	SETSCREW M8x25	8
9	FLAT WASHER M8x22x3.3mm	8
10	WASHER FT M10x25.4x3	14
11	BOLT M10x30 1.5P	4
12	HEX NUT M10x1.5	4
13	BOLT M10-1.5x65 Zn	6
14	SPRING WASHER M16x5x3.5	2
15	BOLT M16x45 2.0P	2
16	PLUG BRACKET	1
17	NUT NYLOC M4-0.7 Z/P	2
18	M10x1.5 TAPPEDPLATE 300mm	4
19	WIRING LOOM	1
20	10mm "D" SHACKLE	2
21	50mm TOWBALL	1
22	ACRYLIC COMPLIANCE PLATE	1

Cequent Customer Service
 Ph: 1800 812 017 Fax: 03 9898 3299
 Email: info@cequent.com.au
 Post: PO Box 4050, Dandenong South VIC 3175

TRAILBOSS

Towbar Fitting Instructions
To Suit **HONDA CIVIC 10TH GEN CL2**
Part Number **HN71L**
Rating **800/50 kg**

PLACE THESE INSTRUCTIONS IN THE VEHICLE'S GLOVEBOX AFTER INSTALLATION IS COMPLETED

1. Remove the 1x screw from the boot cavity.
Repeat for the other side of the vehicle.



2. Remove the 2x screws with washers from the boot cavity (at the tail light assembly).
Repeat for the other side of the vehicle.



3. Remove the tail light assembly. This will require disconnecting the 4x wiring harness connectors.
Repeat for the opposite side of the vehicle.



Cequent Customer Service
Ph: 1800 812 017 Fax: 03 9898 3299
Email: info@cequent.com.au
Post: PO Box 4050, Dandenong South VIC 3175

TRAILBOSS

Towbar Fitting Instructions
To Suit **HONDA CIVIC 10TH GEN CL2**
Part Number **HN71L**
Rating **800/50 kg**

PLACE THESE INSTRUCTIONS IN THE VEHICLE'S GLOVEBOX AFTER INSTALLATION IS COMPLETED

4. Remove the 3x screws from the wheel arch.
Repeat for the opposite side of the vehicle.



5. Remove the 8x scrivets from the edge of the bumper on the underside of the vehicle.

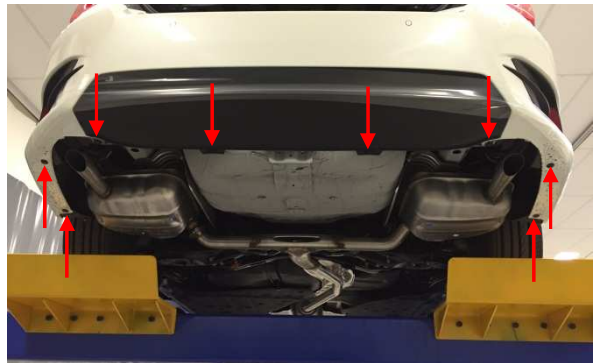

6. Remove the loose trim located at the corner of the underside of the bumper.
Repeat for the opposite side of the vehicle.



Cequent Customer Service
Ph: 1800 812 017 Fax: 03 9898 3299
Email: info@cequent.com.au
Post: PO Box 4050, Dandenong South VIC 3175

TRAILBOSS

Towbar Fitting Instructions
To Suit **HONDA CIVIC 10TH GEN CL2**
Part Number **HN71L**
Rating **800/50 kg**

PLACE THESE INSTRUCTIONS IN THE VEHICLE'S GLOVEBOX AFTER INSTALLATION IS COMPLETED

7. Peel off bumper and disconnect wiring harness.

Note that there are 9 retaining tabs on each side. They should be disconnected starting from the outside tab to the inside tab in order. Then there are four more retaining tabs holding the centre of the bumper to the rear panel.



8. Remove the 4x bolts that secure the impact beam to the rear panel.

Repeat for the opposite side of the vehicle then remove and discard the impact beam.

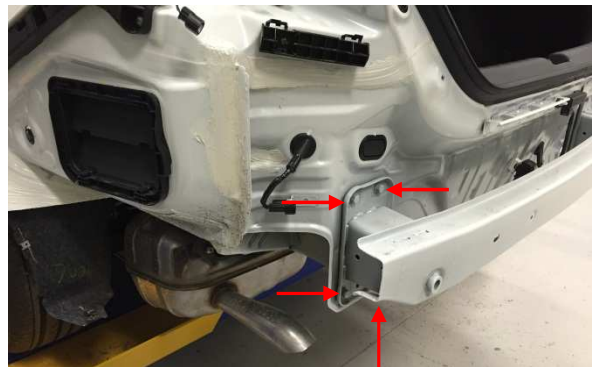

9. Bend the tab at the chassis rail entry that is facing rearwards, 180° so that it faces forwards.

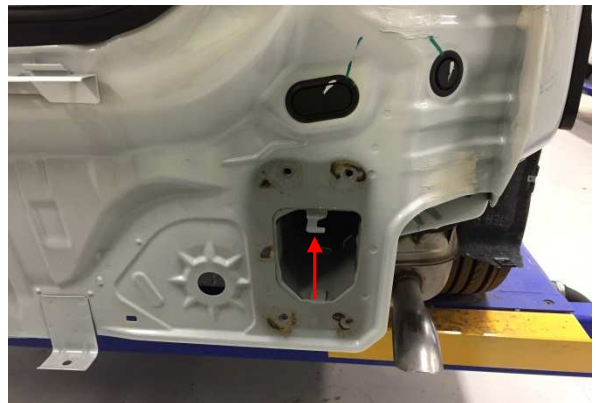

Cequent Customer Service
Ph: 1800 812 017 Fax: 03 9898 3299
Email: info@cequent.com.au
Post: PO Box 4050, Dandenong South VIC 3175

TRAILBOSS

Towbar Fitting Instructions
To Suit **HONDA CIVIC 10TH GEN CL2**
Part Number **HN71L**
Rating **800/50 kg**

PLACE THESE INSTRUCTIONS IN THE VEHICLE'S GLOVEBOX AFTER INSTALLATION IS COMPLETED

10. Release the 1x rubber support that is holding up the muffler.

Repeat for the opposite side of the vehicle.



11. Release the 2x rubber supports under the vehicle that are supporting the exhaust pipes. Gently lower the exhaust making sure that it is temporarily supported.



12. Remove the 3x Screws and remove the heat shield.

Repeat for the opposite side of the vehicle.



Cequent Customer Service

Ph: 1800 812 017 Fax: 03 9898 3299

Email: info@cequent.com.au

Post: PO Box 4050, Dandenong South VIC 3175

TRAILBOSS

Towbar Fitting Instructions To Suit HONDA CIVIC 10TH GEN CL2 Part Number HN71L Rating 800/50 kg

PLACE THESE INSTRUCTIONS IN THE VEHICLE'S GLOVEBOX AFTER INSTALLATION IS COMPLETED

13. Drill a 13 mm hole 72 mm rearwards from the centre of the existing hole in the underside of the chassis rail. Coat exposed rail with suitable rust inhibitor (not provided).

Repeat for the opposite side of the vehicle.

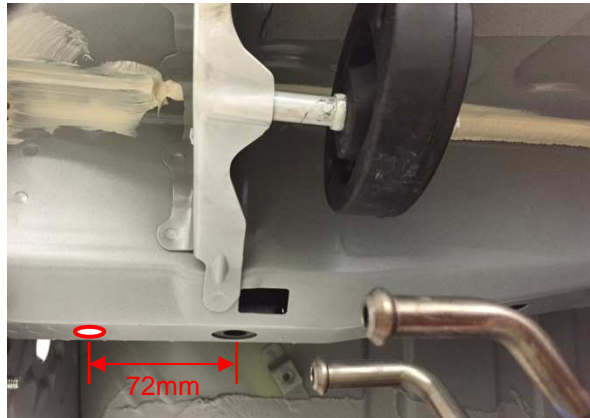

14. Drill a 13 mm hole in the outboard side of the chassis rail that is 52 mm vertically up and 138 mm forward of the original hole in the underside of the chassis rail. Coat exposed rail with suitable rust inhibitor (not provided).

Repeat for the opposite side of the vehicle.

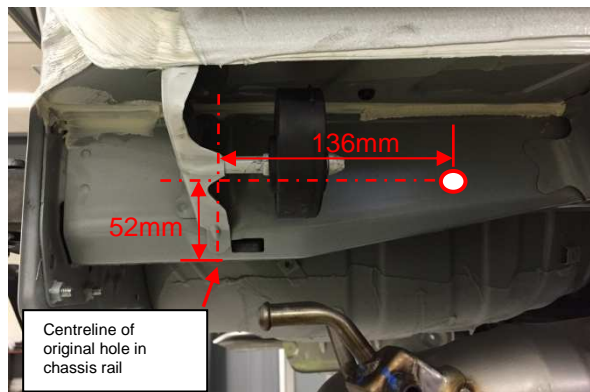

15. Insert the RHS sidearm into the chassis rail and loosely secure the sidearm assembly to the rear panel using 4xM8x25 screws, complete with 1 x M8 flat washer per screw.

Note that the side notch in the mounting plate should be facing the outside of the vehicle.

Repeat for opposite side of vehicle with LHS sidearm.

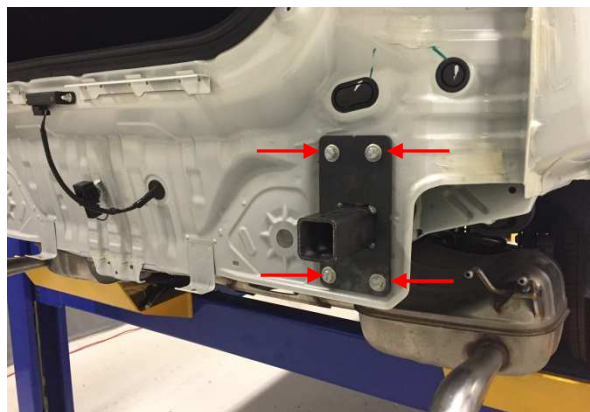

Cequent Customer Service
Ph: 1800 812 017 Fax: 03 9898 3299
Email: info@cequent.com.au
Post: PO Box 4050, Dandenong South VIC 3175

TRAILBOSS

Towbar Fitting Instructions
To Suit **HONDA CIVIC 10TH GEN CL2**
Part Number **HN71L**
Rating **800/50 kg**

PLACE THESE INSTRUCTIONS IN THE VEHICLE'S GLOVEBOX AFTER INSTALLATION IS COMPLETED

16. Insert the tapped plate on the wire down the chassis rail to align with the forward vertical mounting hole.

Note: Make sure the wire is on the top side to allow for insertion of the second tapped plate on the wire in step 18.



17. Install the 1x washer plate with two holes and loosely tighten the 1 x M10 x 65 screw, complete with 1 x M10 Flat Washer.

Repeat steps 16 and 17 for the opposite side of the vehicle.

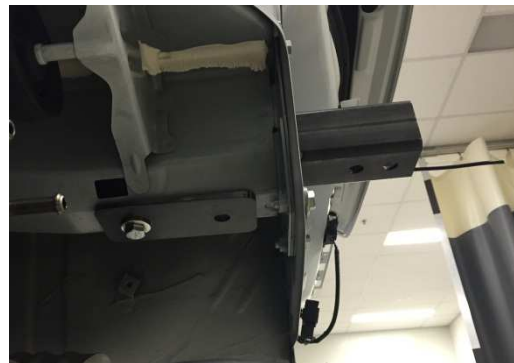

18. Insert tapped plate on the wire down the chassis rail to align with the rear vertical mounting hole.

19. Loosely tighten the 1 x M10 x 65 Screw, complete with 1 x M10 Flat Washer.

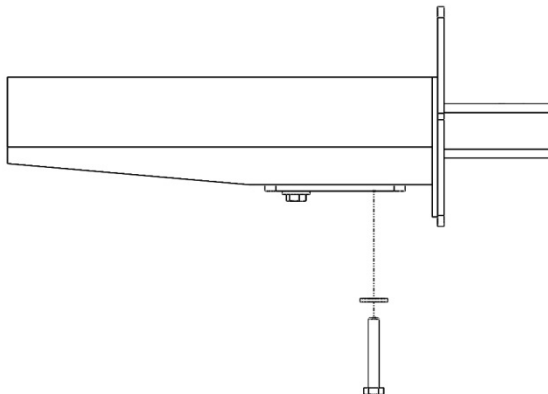

Cequent Customer Service
Ph: 1800 812 017 Fax: 03 9898 3299
Email: info@cequent.com.au
Post: PO Box 4050, Dandenong South VIC 3175



Towbar Fitting Instructions
To Suit **HONDA CIVIC 10TH GEN CL2**
Part Number **HN71L**
Rating **800/50 kg**

PLACE THESE INSTRUCTIONS IN THE VEHICLE'S GLOVEBOX AFTER INSTALLATION IS COMPLETED

20. Install the 1 x washer plate with single hole and loosely tighten the 1 x M10 x 65 screw, complete with 1 x M10 flat washer.

Note that the washer plate should be oriented up as shown in the adjacent picture.

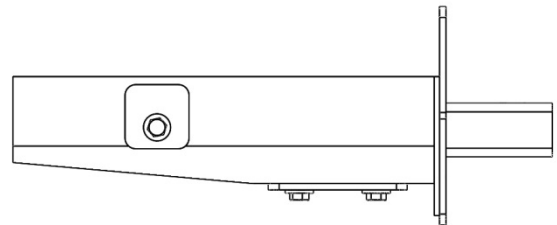

21. Offer the towbar welded assembly to the side arms.

22. Insert shim plate between the side arm and insert to take up the gap.

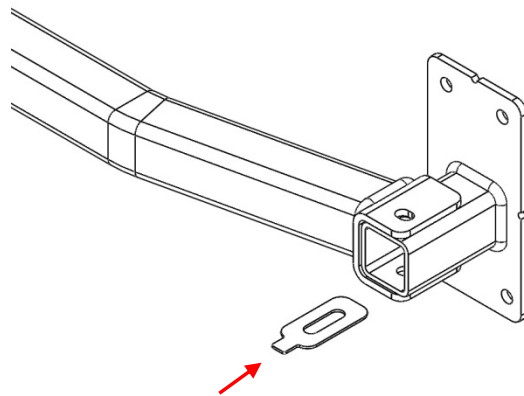

23. Loosely secure towbar welded assembly to sidearm assemblies using 2 x M10 x 30 bolts per side, complete with 2 x flat washers per bolt and 1 x M10 nut per bolt.

24. Tighten all fasteners to torques listed below:

M8 Bolts: 22 N.m
M10 Bolts: 62 N.m

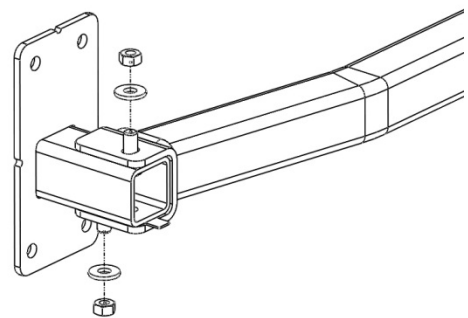

Cequent Customer Service

Ph: 1800 812 017 Fax: 03 9898 3299

Email: info@cequent.com.au

Post: PO Box 4050, Dandenong South VIC 3175

Towbar Fitting Instructions
To Suit **HONDA CIVIC 10TH GEN CL2**
Part Number **HN71L**
Rating **800/50 kg**

PLACE THESE INSTRUCTIONS IN THE VEHICLE'S GLOVEBOX AFTER INSTALLATION IS COMPLETED

25. Offer the tongue to the towbar and tighten the bolts to 146 N.m.

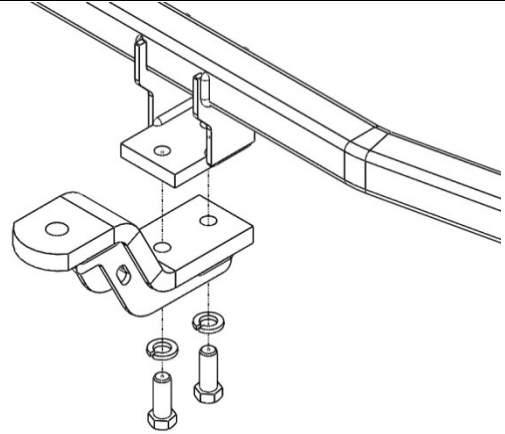

26. Identify centre of bumper, and make cutout in centre of bumper 100 mm wide x 100 mm tall, starting at bottom edge of bumper (as measured on inside of bumper).

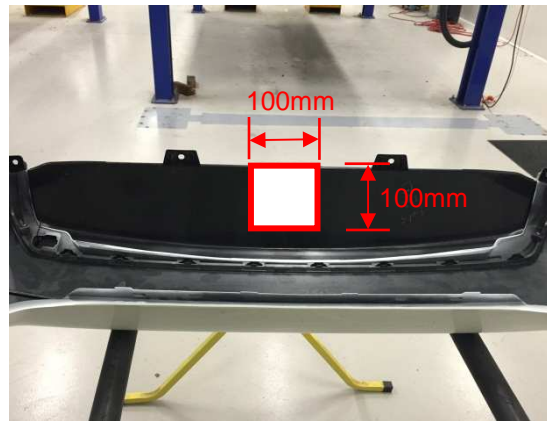

27. Mark out and drill 2 x $\varnothing 5$ mm holes 69mm apart on bumper skin to support plug bracket. Feed bracket threads through drilled holes prior to reinstalling bumper.

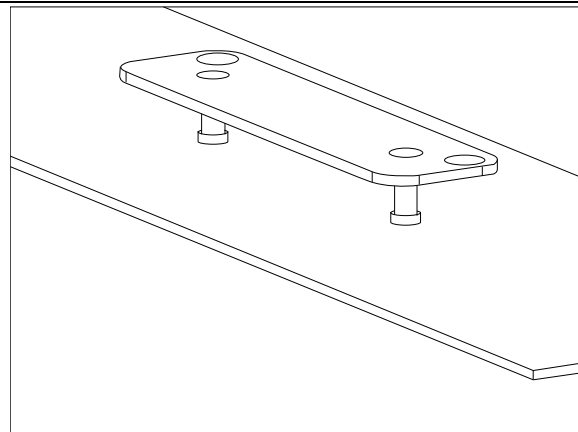

Cequent Customer Service
Ph: 1800 812 017 Fax: 03 9898 3299
Email: info@cequent.com.au
Post: PO Box 4050, Dandenong South VIC 3175



Towbar Fitting Instructions
To Suit **HONDA CIVIC 10TH GEN CL2**
Part Number **HN71L**
Rating **800/50 kg**

PLACE THESE INSTRUCTIONS IN THE VEHICLE'S GLOVEBOX AFTER INSTALLATION IS COMPLETED

28.Reinstall bumper following steps 1-7 and 10-12 in reverse order.	
---	--

<p>Cequent Customer Service Ph: 1800 812 017 Fax: 03 9898 3299 Email: info@cequent.com.au Post: PO Box 4050, Dandenong South VIC 3175</p>
