

TRAILBOSS

Towbar Fitting Instructions
To Suit **MAZDA2 SEDAN** 2010-on
Part Number **MA82L**
Rating **700/70** kg

WARNING:

1. Do not, drill, cut, weld or otherwise modify the tow bar.
2. If you are using electric welding on a motor vehicle, **always** check that the vehicle is not equipped with electronic engine or instrument management equipment. Failure to do so could **destroy** any onboard computers. If in doubt, check with the vehicle's manufacturer.
3. The high tensile fasteners supplied with this product were used to achieve the specified rating. If replacement is required ensure that fasteners of the same rating & quality are used. Contact an authorised **Trailboss** dealer if further information is required.

General:

1. Ensure all hardware items have been included refer to assembly diagram.
2. It is recommended that the instructions are read through and completely understood before making any attempt to fit this product.
3. Be wary of any changes to vehicle designs or other accessories that may conflict with the installation of this product.
4. Before drilling ensure that the area is clear of fuel, electrical & other components.
5. All holes drilled into the body panels shall have all burrs & swarf removed then coated with a suitable rust preventative paint.
6. For vehicles that require the bumper to be cut. Ensure cut out area is in correct position on the vehicle prior to cutting the bumper.
7. The high tensile fasteners supplied with this product were used to achieve the specified rating. If replacement is required ensure that fasteners of the same rating & quality are used. Contact an authorized **Trailboss** dealer if further information is required.
8. Ensure that all hardware is fastened to torque list below check fasteners on regular basis.
9. Tow bar load rating sticker provided with this product shall be conspicuously located on inside rear end of the driver's door. **(See diagram below).**
10. Trailboss recommends that you check your tow ball to ensure that it complies with the Australian standards **AS 4177.2.**
11. **PLEASE NOTE:** It is advised to remove your lug or tbn when not actually towing so as to produce a clear view of the vehicles registration plate if obscured, and to also provide maximum available departure angle
12. Pull Pin must be fit in down position.

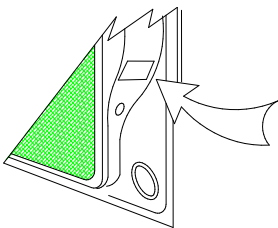

Place load rating sticker
inside driver's door here

FOR TRAILER TOWING PURPOSES ONLY
For towing capacity details please refer to vehicle owner's manual or to the manufacturer. Overloading can void your warranties.

RECOMMENDED ASSEMBLY TORQUE LISTING

<u>Diameter</u>	<u>Grade 8.8 Bolt</u>
M6	9.5 Nm
M8	21.7 Nm
M10	43.4 Nm
M12	77.3Nm
M14	146 Nm
M16	189.8 Nm

Tow bar Maintenance and Care.

Trailboss recommends that bolt torque's, as listed below, are routinely and regularly inspected and checked for correct tension. Replace any worn or defective parts.

We recommended to remove Tow Ball Mounts (TBM's, tongues or lugs) when not being used for any considerable length of time.

So as to avoid injury, when not towing it is suggested that the tongue, Pull Pin and R-clip are removed then stored in a safe, clean and dry place, away from excessive moisture.

Hitch Pull Pins and spring "R" clips are regularly checked for proper installation. Replace any worn or defective parts.

TRAILBOSS

Towbar Fitting Instructions
To Suit **MAZDA2 SEDAN** 2010-on
Part Number **MA82L**
Rating **700/70** kg

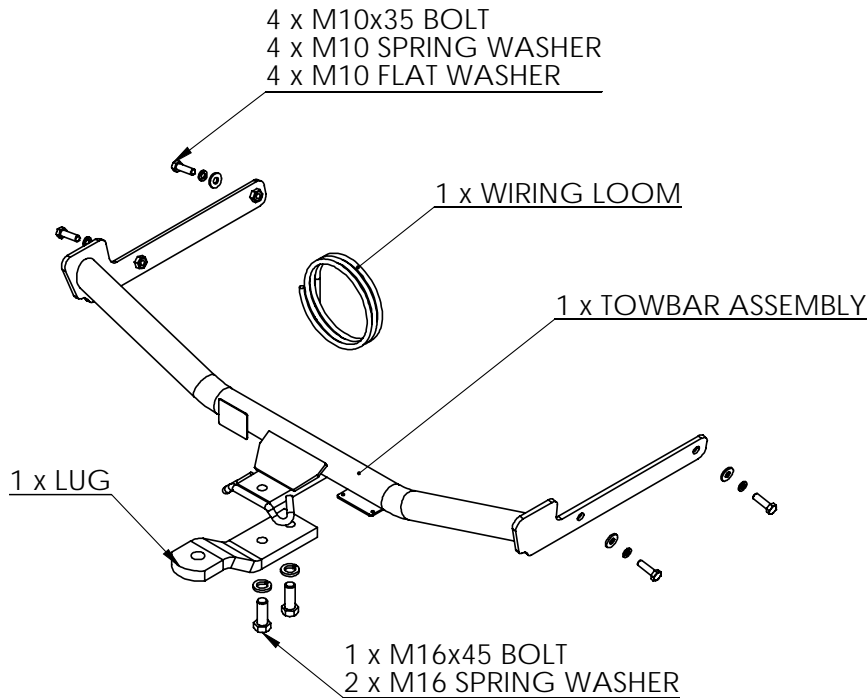

1. Remove 4 screws and 1 skrivet around wheel arch area on both sides.
2. Remove 2 skrivets under the bumper.
3. Open the boot lid and remove 2 screws between the cavities.
4. Loosen taillight assemblies via accessing from inside the boot.
5. Remove bumper and disconnect and wirings connecting to the bumper.
6. Using appropriate tool, cut open rear panel to access to chassis rails.
7. Fit towbar inside chassis rails, fit towbar using M10 bolts, washers, and spring washers supplied.
8. Torque all fasteners to specifications.
9. Using numberplate lights as a guide, cut 120mm wide by 55mm deep from the bottom of the bumper bar.
10. Refit bumper bar to vehicle.



Wiring Loom Fitting Instructions
To Suit Mazda 2 Sedan
Part Number 100505-WL

Wiring Loom Installation Instructions

Mazda 2 Sedan
Part No: 100505-WL

Tail Length Required: 1200mm

RPA Override Switch Part No: 04848 (If Fitted)

Wiring Loom Installation Time: Approx 30 Mins



Wiring Loom Fitting Instructions
To Suit Mazda 2 Sedan
Part Number 100505-WL

1. In the luggage compartment, remove the floor cover carpet.
2. Remove the rear trim by first removing the two clips.
3. Remove the LHS side trim by first removing the five clips.
4. Remove the RHS tail light access panel cover.
5. Remove the LHS grommet.
6. Drill out the grommet hole to Ø31mm.
7. File any rough or sharp edges and spray on rust inhibitor.
8. Remove the luggage compartment foam tool tray.
9. Route the trailer patch harness (P/No:100505-WL) under the RHS side trim and up towards the RHS tail light assembly.
10. Disconnect the RHS tail light indicator 3-way connector.
11. Patch in the trailer patch mating connector.
12. Route the trailer patch harness from the RHS tail light assembly and towards the rear of the luggage compartment.
13. Route the trailer patch harness along the rear of the luggage compartment towards the LHS.
14. Route the trailer patch harness towards the LHS tail light assembly.
15. Disconnect the LHS tail light connectors.
16. Patch in the trailer patch mating connectors.
17. In the upper LHS of the luggage compartment, locate the white connector.
18. Following the table below, connect the ezy tap to the vehicle 'RED/YELLOW' reverse wire, then connect the trailer harness 'BLACK' reverse wire terminal to the ezy tap .

Function	Trailer Patch	Vehicle Connector
REVERSE	BLACK	RED / YELLOW

19. Connect the trailer patch harness ground ring terminal to the LHS tail light assembly bolt.
20. Mount the trailer socket to the towbar mounting bracket using M4 fasteners (not supplied).
21. Route the tail harness across the towbar towards the RHS of the vehicle and up through the previously drilled out hole.



Wiring Loom Fitting Instructions
To Suit Mazda 2 Sedan
Part Number 100505-WL

22. Ensure the tail harness grommet is seated correctly and secure in place using a cable tie (not supplied).
23. Connect the tail harness (tail length 1200mm) 8-way connector to the trailer harness mating 8-way connector.
24. Test the Trailer socket using a light board or multi-meter.
25. Secure all harnesses using cables ties (not supplied).
26. Re-fit all removed parts and secure all fasteners, ensuring there are no squeaks or rattles.
27. Place instructions in glove box after fitment.