

# TRAILBOSS

## Towbar Fitting Instructions To Suit MAZDA 3 SEDAN 2013 - ON Part Number MA84L Rating 1200/120 kg

PLACE THESE INSTRUCTIONS IN THE VEHICLE'S GLOVEBOX AFTER INSTALLATION IS COMPLETED

### WARNING:

1. Do not, drill, cut, weld or otherwise modify the tow bar.
2. If you are using electric welding on a motor vehicle, **always** check that the vehicle is not equipped with electronic engine or instrument management equipment. Failure to do so could **destroy** any onboard computers. If in doubt, check with the vehicle's manufacturer.
3. The high tensile fasteners supplied with this product were used to achieve the specified rating. If replacement is required ensure that fasteners of the same rating & quality are used. Contact an authorised **Trailboss** dealer if further information is required.

### General:

1. Ensure all hardware items have been included refer to assembly diagram.
2. It is recommended that the instructions are read through and completely understood before making any attempt to fit this product.
3. Be wary of any changes to vehicle designs or other accessories that may conflict with the installation of this product.
4. Before drilling ensure that the area is clear of fuel, electrical & other components.
5. All holes drilled into the body panels shall have all burrs & swarf removed then coated with a suitable rust preventative paint.
6. For vehicles that require the bumper to be cut. Ensure cut out area is in correct position on the vehicle prior to cutting the bumper.
7. The high tensile fasteners supplied with this product were used to achieve the specified rating. If replacement is required ensure that fasteners of the same rating & quality are used. Contact an authorized **Trailboss** dealer if further information is required.
8. Ensure that all hardware is fastened to torque list below check fasteners on regular basis.
9. Tow bar load rating sticker provided with this product shall be conspicuously located on inside rear end of the driver's door. **(See diagram below)**.
10. Trailboss recommends that you check your tow ball to ensure that it complies with the Australian standards **AS 4177.2**.
11. **PLEASE NOTE:** It is advised to remove your lug or tbm when not actually towing so as to produce a clear view of the vehicles registration plate if obscured, and to also provide maximum available departure angle
12. Pull Pin must be fit in down position.

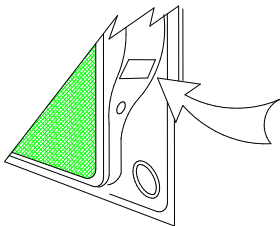

Place load rating sticker  
inside driver's door here

**FOR TRAILER TOWING PURPOSES ONLY**  
For towing capacity details please refer to vehicle owner's manual or to the manufacturer. Overloading can void your warranties.

#### RECOMMENDED ASSEMBLY TORQUE LISTING

Diameter	Grade 8.8 Bolt
M6	9.5 Nm
M8	21.7 Nm
M10	43.4 Nm
M12	77.3Nm
M14	146 Nm
M16	189.8 Nm

### Tow bar Maintenance and Care.

Trailboss recommends that bolt torque's, as listed below, are routinely and regularly inspected and checked for correct tension. Replace any worn or defective parts.

We recommended to remove Tow Ball Mounts (TBM's, tongues or lugs) when not being used for any considerable length of time.

So as to avoid injury, when not towing it is suggested that the tongue, Pull Pin and R-clip are removed then stored in a safe, clean and dry place, away from excessive moisture.

Hitch Pull Pins and spring "R" clips are regularly checked for proper installation. Replace any worn or defective parts.

# TRAILBOSS

Towbar Fitting Instructions  
 To Suit **MAZDA 3 SEDAN 2013 - ON**  
 Part Number **MA84L**  
 Rating **1200/120 kg**

PLACE THESE INSTRUCTIONS IN THE VEHICLE'S GLOVEBOX AFTER INSTALLATION IS COMPLETED

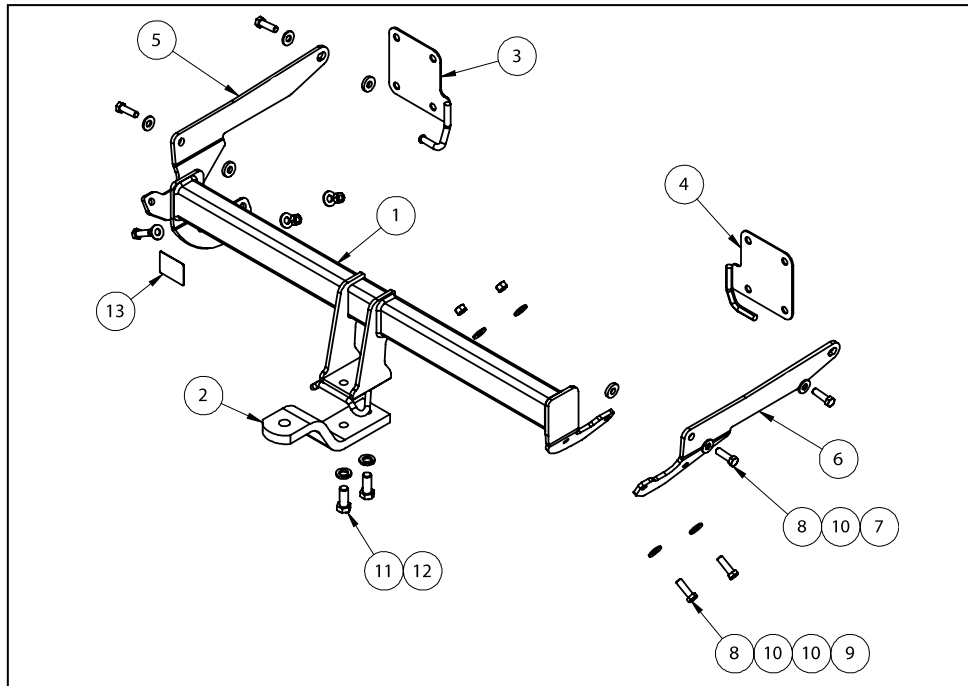

QTY.	DESCRIPTION	ITEM NO.
1	MAZDA 3 WELDED TOWBAR	1
1	TRAILER BALL MOUNT	2
1	EXHAUST MOUNT LHS	3
1	EXHAUST MOUNT RHS	4
1	SIDE ARM LHS	5
1	SIDEARM RHS	6
4	6mm SPACER	7
8	SET SCREW M12-1.25x45	8
4	HEX NUT M12x1.25	9
12	WASHER FLAT M12	10
2	BOLT M16-2.00 x 40	11
2	SPRING WASHER M16x5x3.5	12
1	ADR COMPLIANCE LABEL	13

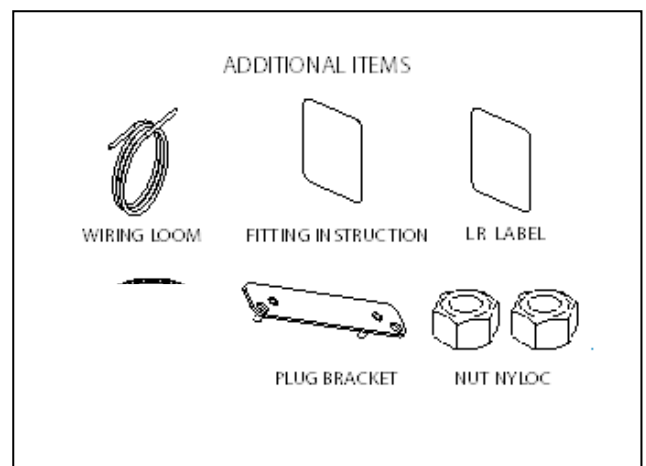



Towbar Fitting Instructions  
To Suit **MAZDA 3 SEDAN 2013 - ON**  
Part Number **MA84L**  
Rating **1200/120 kg**

PLACE THESE INSTRUCTIONS IN THE VEHICLE'S GLOVEBOX AFTER INSTALLATION IS COMPLETED

**INSTRUCTION:**

1. Remove 2x Screws inside rear wheel arch.  
  
Pull back internal trim and remove additional screw on Bumper.  
  
Repeat for other side.
2. Remove 1x Scrivet on both sides from the underside of Bumper to back panel.
3. Open Boot, remove 1x Scrivet and unclip plastic trim.  
  
Remove 1x Scrivet from carpet to sheet metal and pull back carpet.
4. Remove 3x Nuts from the rear of tail light and remove light assembly.
5. Remove 1x Screw on the LHS of the taillight cavity and 1x Screw below the taillight.  
  
Repeat for other side.
6. Remove 2x Screws from underside of Bumper on both sides unclip the sides of the Bumper by pulling firmly and remove Bumper.
7. Unhook exhaust hangers, remove Impact Beam & discard.  
  
Retain the impact beam nuts for later use.
8. Attach the LHS Sidearm loosely to the vehicle using 2 x M12 Bolts and 2 x M12 Washer.  
  
Repeat for RHS.
9. Attach the LHS & RHS Exhaust Hanger mounts to the back panel of the vehicle. Re-use the 8 x Nuts removed in Step 7.  
  
Torque to recommended settings.  
  
Re-hook the Exhaust Hanger.
10. Offer the main Towbar assembly to the sidearms attached to the vehicle.  
  
Loosely secure each side with 2 x M12 Bolts, 4 x M12 Flat Washers and 2 x M12 Nuts.  
  
- Tighten all Bolts to the following torque settings: 8 x M12 x 1.25P = 120Nm
11. Perform the bumper cut out as per the bumper cut template found on the final page of these instructions. Centre the template on the lower edge of the bumper and cut out.  
  
Note: Drill out two 5mm holes, 69mm apart for the plug bracket, on the LHS of the bumper.  
  
Re-fit bumper and all other components in reverse order.



Towbar Fitting Instructions  
To Suit MAZDA 3 SEDAN 2013 - ON  
Part Number MA84L  
Rating 1200/120 kg

PLACE THESE INSTRUCTIONS IN THE VEHICLE'S GLOVEBOX AFTER INSTALLATION IS COMPLETED

**MAZDA 3 SEDAN BUMPER CUT TEMPLATE**

NOTE: MEASURE THE TEMPLATE TO CHECK IF TO SCALE.

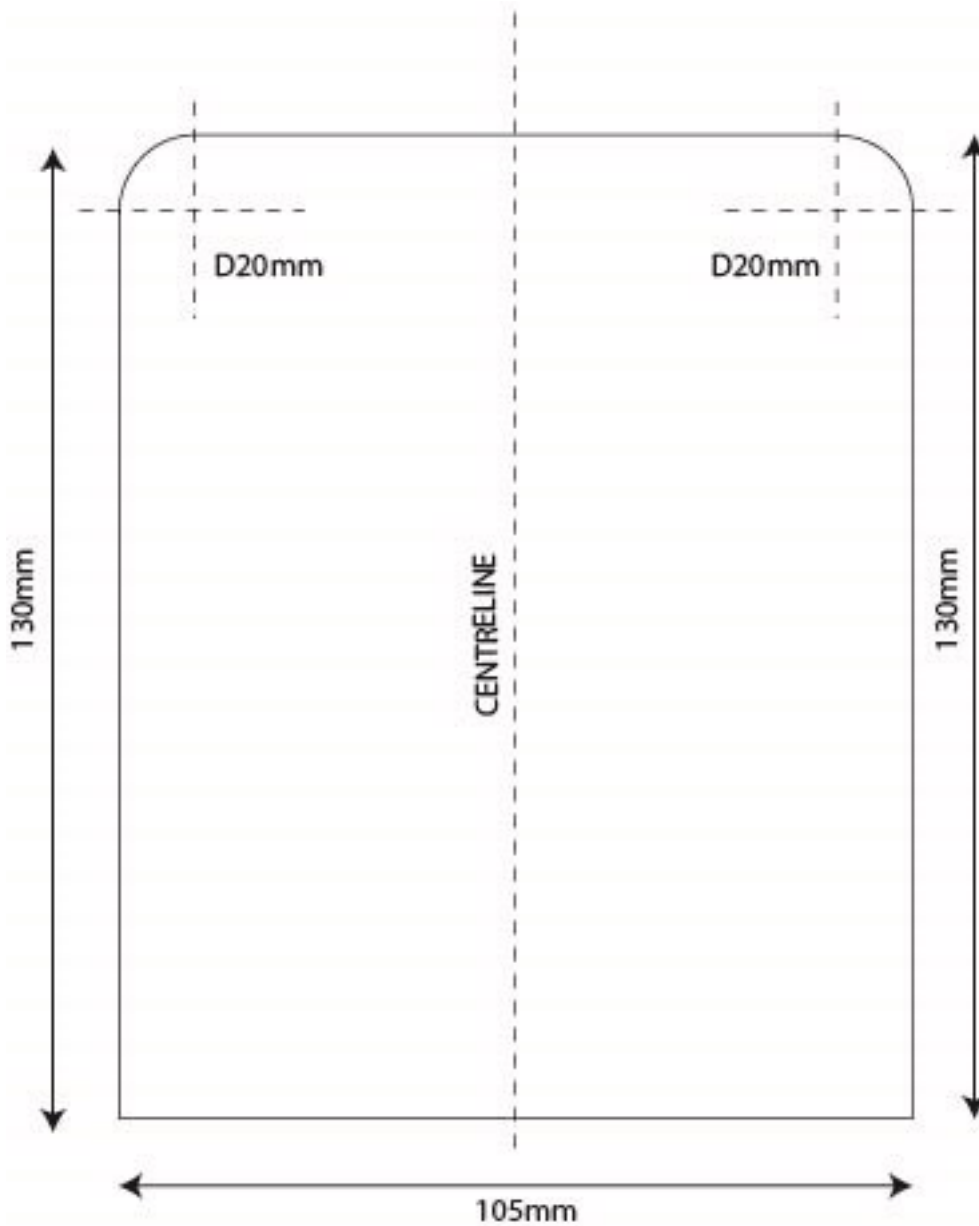



Wiring Loom Fitting Instructions  
To Suit Mitsubishi Lancer Hatch MY13,  
Mazda 3 Hatch, Mazda 3 Sedan  
Part Number 101028-WL

### Wiring Loom Installation Instructions

Mitsubishi Lancer Hatch MY13 (pages 1 - 4)  
Mazda 3 Hatch (pages 5 - 6)  
Mazda 3 Sedan (pages 7 -8)

Part No: 101028-WL

Lancer Tail Harness Length Required: 1200mm  
Mazda3 Tail Harness Length Required: 1800mm

ECU Required: 04826

Wiring Loom Installation Time: Approx 45 Mins



Wiring Loom Fitting Instructions  
To Suit Mitsubishi Lancer Hatch MY13,  
Mazda 3 Hatch, Mazda 3 Sedan  
Part Number 101028-WL

Lancer Hatch MY13

1. In the luggage compartment, remove the parcel shelf.
2. Remove the carpet cover.
3. Fold down the rear seats.
4. Remove the two rear fasteners.
5. Remove the rear luggage compartment trim.
6. Remove the three fasteners and remove the plastic trim.
7. On the LHS of the luggage compartment, remove the storage cover by removing the screw.
8. Remove the three screws on the luggage compartment trim .
9. Remove the luggage compartment trim.

Repeat for the RHS.

10. Remove the LHS rear door trim.
11. Remove the LHS passengers door trim and the kick panel trim.
12. On the LHS of the rear quarter panel, drill a Ø 30mm hole on the indicated location.
13. On the RHS of the luggage compartment, connect the 2-way trailer patch connector to its mating 2-way vehicle tail light assembly connectors.
14. Route the trailer patch towards the LHS of the vehicle.
15. On the LHS of the luggage compartment, connect the 2-way & 3-way trailer patch connector to its mating 2-way & 3-way vehicle tail light assembly connectors.
16. On the LHS of the luggage compartment, connect the trailer patch 12-way connector to the ECU (04826).
17. Apply double sided tape to the ECU and adhere it to the vehicle sheet metal in a suitable location.

# TRAILBOSS

## Wiring Loom Fitting Instructions To Suit Mitsubishi Lancer Hatch MY13, Mazda 3 Hatch, Mazda 3 Sedan Part Number 101028-WL

18. Following the table below, connect the ezy-tap (1) to the LIGHT BLUE wire (2), then connect the terminal (3) to the ezy-tap (1).

19. Connect the trailer patch ring terminal (4) to the existing vehicle grounding point.

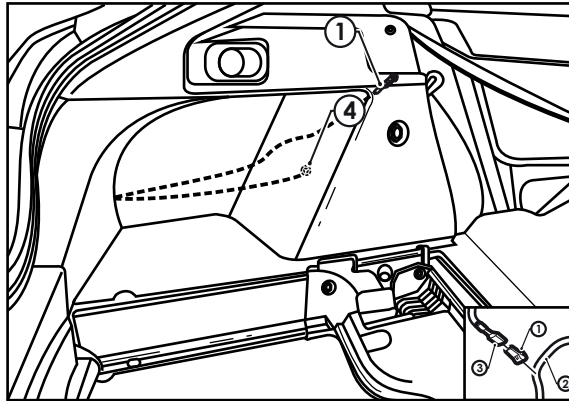

Function	Trailer Patch	Vehicle Connector
REVERSE	BLACK / WHITE	LIGHT BLUE

20. In the glove box area, remove the 20-amp fuse (1).

21. Insert the previously removed 20-amp fuse (2) into the supplied add-a-fuse harness (3) lower slot as shown.

22. Insert the 20-amp fuse (4) into the supplied add-a-fuse harness (3) upper slot as shown.

23. Connect the trailer patch 1-way connector (5) to the add-a-fuse harness (3).

24. Connect the add-a-fuse harness (3) into the fuse panel now vacant fuse location in the orientation shown.

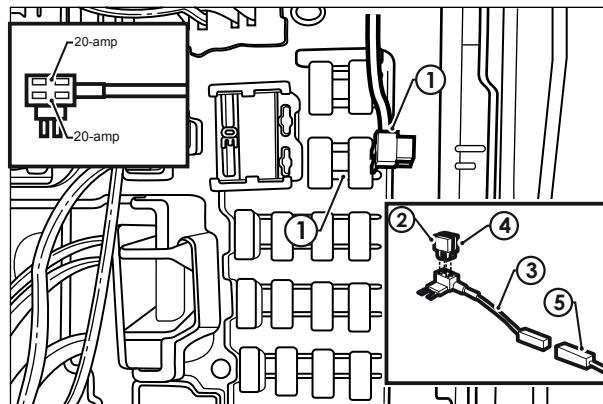



Wiring Loom Fitting Instructions  
To Suit Mitsubishi Lancer Hatch MY13,  
Mazda 3 Hatch, Mazda 3 Sedan  
Part Number 101028-WL

25. Mount the tail harness socket to the towbar mounting bracket using M4 fasteners (not supplied).
26. Route the tail harness towards the LHS, up through the previously drilled grommet hole.
27. Ensure the tail harness grommet is seated correctly and secured in place using a cable tie (not supplied).
28. Connect the tail harness (tail length 1200mm) 8-way connector to the trailer harness mating 8-way connector.
29. Test the trailer patch function using a lightboard or multimeter.
30. Secure all harnesses using cable ties (not supplied).
31. Re-fit all removed parts and secure all fasteners, ensuring there are no squeaks or rattles.
32. Place the fitting instructions in the glove box after fitment.





Wiring Loom Fitting Instructions  
To Suit Mitsubishi Lancer Hatch MY13,  
Mazda 3 Hatch, Mazda 3 Sedan  
Part Number 101028-WL

Mazda 3 Hatch

1. In the luggage compartment, remove the rear shelf/shade trim. Remove the luggage compartment carpet trim. Remove luggage compartment rear trim by removing the two fasteners.
2. Dislodge the RHS luggage side trim. Remove the RHS upper compartment trim. Remove the luggage compartment hooks and clip. Repeat for the LHS.
3. Remove the 5 clips from the luggage compartment trim and then remove trim. Repeat for the LHS.
4. At the rear passenger side, remove the door sill trim. Dislodge the 'B' pillar trim panel.
5. At the front of the vehicle, remove the door sill trim and remove the kick panel trim.
6. At the LHS rear 3/4 area of the vehicle, locate the vehicle Ø30mm grommet on the floor.
7. If the grommet is not available, drill out a Ø30 mm hole in the sheet metal near the grommet location. Apply rust inhibitor after drilling.
8. Disconnect the vehicle LHS 2-way and 3-way taillight connectors and patch the trailer patch (P/No: 10128-WL) in between.
9. Secure the trailer patch ground to the vehicle grounding point.
10. Connect the trailer patch ECU connector to the ECU and mount the ECU into place as shown.
11. For reverse signal, locate the vehicle harness above the wheel arch area and remove the electrical tape. Locate and splice the trailer patch BLACK/WHITE reverse wire to the vehicle RED wire.
12. Route the trailer patch across to the RHS. Disconnect the vehicle harness 2-way connector and patch the trailer patch harness in between.
13. Route the trailer patch harness 1-way connector branch along the LHS of the vehicle towards the front of the vehicle.
14. At the front passenger kick panel trim area, secure the supplied 20A fuse to the add-a-fuse harness upper slot (empty slot).
15. Connect the trailer patch 1-way connector to the add-a-fuse harness and slot into the vacant slot.
16. At the rear of the vehicle, secure the tail harness socket (tail length: 1800mm) to the towbar mounting location using M4 fasteners (not supplied).
17. Route the tail harness to the LHS grommet/drilled hole location. Ensure the tail harness grommet is seated correctly. Adjust the tail harness grommet as required and secure after.



Wiring Loom Fitting Instructions  
To Suit Mitsubishi Lancer Hatch MY13,  
Mazda 3 Hatch, Mazda 3 Sedan  
Part Number 101028-WL

18. Retrieve the tail harness and connect the tailharness (tail length 1800mm) 8-way connector to the trailer patch mating 8-way connect or.
19. Test the trailer patch function using a lightboard or multimeter.
20. Secure all harnesses using cable ties (not supplied).
21. Re-fit all removed parts and secure all fasteners, ensuring there are no squeaks or rattles.
22. Place the fitting instructions in the glove box after fitment.



Wiring Loom Fitting Instructions  
To Suit Mitsubishi Lancer Hatch MY13,  
Mazda 3 Hatch, Mazda 3 Sedan  
Part Number 101028-WL

Mazda 3 Sedan

1. Remove the luggage compartment carpet trim.
2. Remove the rear trim by removing the two fasteners.
3. Remove the LHS luggage compartment trim by removing the 4 fasteners/clips. Repeat for the LHS.
4. Remove the LHS rear passenger door sill trim, remove the front passenger door sill trim, dislodge the 'B' pillar lower trim. Remove the front passenger's kick trim.
5. Drill out a Ø30mm hole in the sheet metal near the grommet location. Apply rust inhibitor after drilling.
6. Disconnect the vehicle LHS 2-way and 3-way taillight connectors and patch the trailer patch (P/No: 10128-WL) in between.
7. Secure the trailer patch ground to the vehicle sheet metal at a suitable location using a tek screw (not supplied).
8. Connect the trailer patch ECU connector to the ECU and mount the ECU to a suitable location onto the LHS rear wheel arch. Route the trailer patch across to the RHS.
9. Disconnect the vehicle harness 2-way connector and patch the trailer patch harness 2-way connectors in between.
10. For reverse signal, locate the vehicle harness near the LHS wheel arch and vent area and remove the electrical tape from the vehicle harness. Locate and splice the trailer patch BLACK/WHITE reverse wire to the vehicle RED wire. Note: Use a multi-meter to determine the correct wire as there is more than one RED wire in the vehicle harness.
11. At the kick panel trim area, secure the supplied 20A fuse to the add-a-fuse harness upper slot (empty slot). Connect the trailer patch 1-way connector to the add-a-fuse harness and slot into the vacant slot.
12. Route the trailer patch harness 1-way connector branch along the LHS of the vehicle towards the front of the vehicle.
13. Retrieve the tail harness and connect the tail harness (tail length 1800mm) 8-way connector to the trailer patch mating 8-way connector.
14. Test the trailer patch function using a lightboard or multimeter.
15. Secure all harnesses using cable ties (not supplied).
16. Re-fit all removed parts and secure all fasteners, ensuring there are no squeaks or rattles.
17. Place the fitting instructions in the glove box after fitment.