

TRAILBOSS

Towbar Fitting Instructions To Suit **OPEL ASTRA STATION WAGON 03/13 ON** Part Number **OP01L** Rating **1300/75 kg**

PLACE THESE INSTRUCTIONS IN THE VEHICLE'S GLOVEBOX AFTER INSTALLATION IS COMPLETED

WARNING:

1. Do not, drill, cut, weld or otherwise modify the tow bar.
2. If you are using electric welding on a motor vehicle, **always** check that the vehicle is not equipped with electronic engine or instrument management equipment. Failure to do so could **destroy** any onboard computers. If in doubt, check with the vehicle's manufacturer.
3. The high tensile fasteners supplied with this product were used to achieve the specified rating. If replacement is required ensure that fasteners of the same rating & quality are used. Contact an authorised **Trailboss** dealer if further information is required.

General:

1. Ensure all hardware items have been included refer to assembly diagram.
2. It is recommended that the instructions are read through and completely understood before making any attempt to fit this product.
3. Be wary of any changes to vehicle designs or other accessories that may conflict with the installation of this product.
4. Before drilling ensure that the area is clear of fuel, electrical & other components.
5. All holes drilled into the body panels shall have all burrs & swarf removed then coated with a suitable rust preventative paint.
6. For vehicles that require the bumper to be cut. Ensure cut out area is in correct position on the vehicle prior to cutting the bumper.
7. The high tensile fasteners supplied with this product were used to achieve the specified rating. If replacement is required ensure that fasteners of the same rating & quality are used. Contact an authorized **Trailboss** dealer if further information is required.
8. Ensure that all hardware is fastened to torque list below check fasteners on regular basis.
9. Tow bar load rating sticker provided with this product shall be conspicuously located on inside rear end of the driver's door. **(See diagram below)**.
10. Trailboss recommends that you check your tow ball to ensure that it complies with the Australian standards **AS 4177.2**.
11. **PLEASE NOTE:** It is advised to remove your lug or tbm when not actually towing so as to produce a clear view of the vehicles registration plate if obscured, and to also provide maximum available departure angle
12. Pull Pin must be fit in down position.

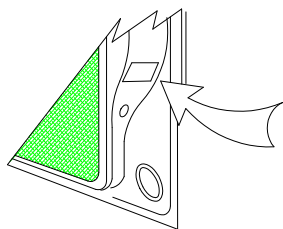

Place load rating sticker
inside driver's door here

FOR TRAILER TOWING PURPOSES ONLY
For towing capacity details please refer to vehicle owner's manual or to the manufacturer. Overloading can void your warranties.

RECOMMENDED ASSEMBLY TORQUE LISTING

Diameter	Grade 8.8 Bolt
M6	9.5 Nm
M8	21.7 Nm
M10	43.4 Nm
M12	77.3Nm
M14	146 Nm
M16	189.8 Nm

Tow bar Maintenance and Care.

Trailboss recommends that bolt torque's, as listed below, are routinely and regularly inspected and checked for correct tension. Replace any worn or defective parts.

We recommended to remove Tow Ball Mounts (TBM's, tongues or lugs) when not being used for any considerable length of time.

So as to avoid injury, when not towing it is suggested that the tongue, Pull Pin and R-clip are removed then stored in a safe, clean and dry place, away from excessive moisture.

Hitch Pull Pins and spring "R" clips are regularly checked for proper installation. Replace any worn or defective parts.

TRAILBOSS

Towbar Fitting Instructions
 To Suit **OPEL ASTRA STATION WAGON 03/13 ON**
 Part Number **OP01L**
 Rating **1300/75 kg**

PLACE THESE INSTRUCTIONS IN THE VEHICLE'S GLOVEBOX AFTER INSTALLATION IS COMPLETED

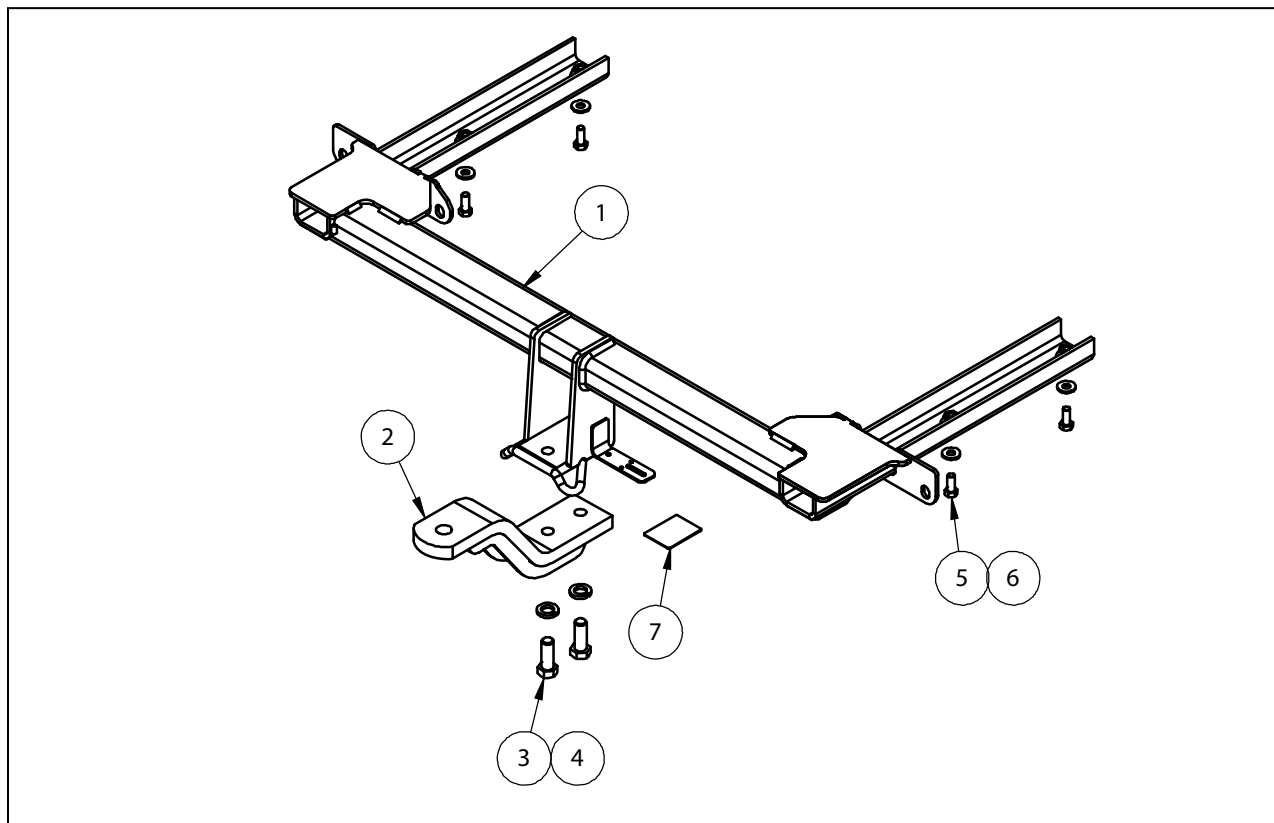

QTY	DESCRIPTION	ITEM NO.
1	WELDED ASSEMBLY	1
1	LUG ASSEMBLY c/w REINFORCE	2
2	M16 X 5 X 3.5 SPRING WASHER	3
2	M16 x 45 2.0P BOLT	4
4	BOLT M10-1.50 x 25	5
4	WSHR FT M10 X 25.4 X 3	6
1	ACRYLIC COMPLIANCE PLATE	7

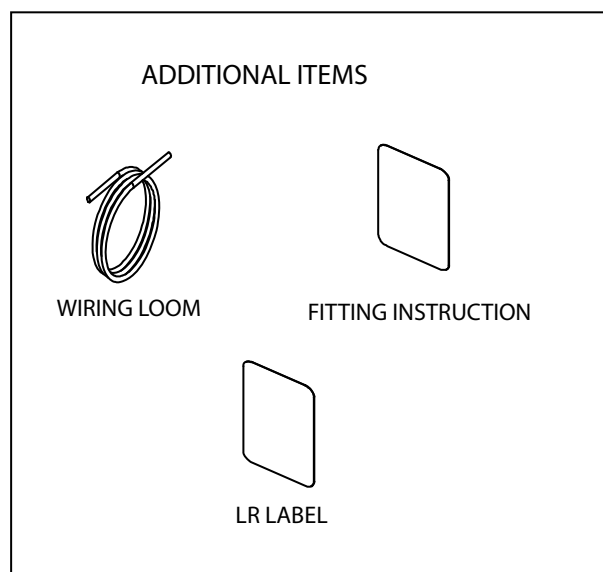



Towbar Fitting Instructions
To Suit **OPEL ASTRA STATION WAGON 03/13 ON**
Part Number **OP01L**
Rating **1300/75 kg**

PLACE THESE INSTRUCTIONS IN THE VEHICLE'S GLOVEBOX AFTER INSTALLATION IS COMPLETED

INSTRUCTION:

1. Remove 3 x Scrivets from the inside of the Driver Side Wheel Well. Repeat for passenger side.
2. Remove 2 x Plastic fasteners from underneath the Bumper.
3. Open Tailgate and open Driver Side access flap. Within Panel unscrew and remove 2 x plastic Wing Nuts. Disconnect cable and carefully remove Taillight, place in safe place. Repeat for passenger side.
4. Remove Screws from each side of Bumper.
5. Carefully remove Bumper and place in safe place, ensuring that Rear Parking Sensor Cable has been disconnected. Remove 6x Keps Nuts to remove Impact Beam. Repeat for other side. Dispose of Impact Beam and 2 x Keps Nuts.
6. Offer Towbar to vehicle, inserting Towbar through openings in vehicle Rear panel. Loosely fasten 4x Keps Nuts removed earlier to the vehicle Back Panel.
7. Loosely fasten Chassis insert with 2x M10 Bolts and 2 xM10 Washers to Chassis Rail. Repeat process for other side.
8. Tighten all fasteners to the Torque Specifications on page 1.
9. To make room for the Towbar, cut a section from the centre of the Bumper. Make a cut of total width 120mm and length 150mm from the bottom of the Bumper.
10. Reassemble Bumper assembly using steps 1 to 4 in reverse.



Wiring Loom Fitting Instructions
To Suit Opel Astra Hatch / Wagon / Insignia
Part Number 100906-WL

Wiring Loom Installation Instructions

Opel Astra Hatch / Wagon / Insignia
Part No: 100906-WL

Tail Harness Length Required: 1800mm
ECU Required: 04836

Astra Wagon: Page 2 – 4

Astra Hatch: Page 5 – 7

Insignia Sport Tourer: Page 8 - 10

Wiring Loom Installation Time: Approx 45 Mins

Wiring Loom Fitting Instructions To Suit Opel Astra Hatch / Wagon / Insignia Part Number 100906-WL

The following steps are for Opel Astra Wagon models only. For Opel Astra Hatch, please proceed to page 5. For Opel Insignia Sport Tourer, please proceed to page 8.

1. In the luggage compartment, remove the floor carpet cover.
2. Remove the rear luggage compartment trim.
3. On the LHS of the luggage compartment, remove the two cargo hook and the screw.
4. Remove the LHS luggage compartment trim by carefully disconnecting the light connector and the 12v accessory connector.
5. On the RHS of the luggage compartment, remove the two cargo hooks and the screw.
6. Remove the RHS luggage compartment trim.
7. On the LHS 'C' pillar trim, remove the two screws.
8. Remove the 'C' pillar trim.
9. On the LHS rear quarter panel of the luggage compartment, drill a Ø30mm hole next to the air vent.
10. File any rough or sharp edges and spray with rust inhibitor.
11. On the LHS of the luggage compartment, following the table below, connect the supplied ezy taps (1) to the existing vehicle wire (2), then connect the trailer patch terminals (3) to the ezy taps (1).

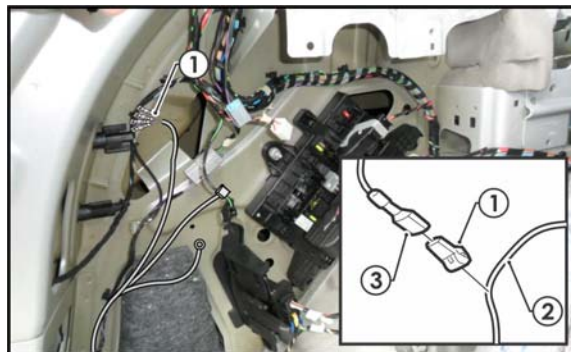

Function	Trailer Patch	Vehicle Connector
L.IND	YELLOW / BLACK	BLUE / WHITE
REVERSE	BLACK / WHITE	GREEN / WHITE
TAIL	BROWN / BLACK	PURPLE / GREY
BRAKES	RED / BLACK	GREY / YELLOW

Wiring Loom Fitting Instructions To Suit Opel Astra Hatch / Wagon / Insignia Part Number 100906-WL

12. Connect the trailer patch 12-way connector to the ECU.
13. Apply the double sided tape to the ECU and adhere it onto a suitable location on the sheet metal.
14. Using a tek screw, secure the trailer patch ground ring terminal to the sheet metal in a suitable location
15. Route the 'ORANGE' power wire (1) along the LHS of the luggage compartment towards the fuse panel.
16. Locate and remove the 30amp fuse (2) on fuse location 'F31'.
17. Insert the supplied 20-amp fuse (3) into the upper slot of the add-a-fuse harness (4).
18. Insert the previously removed 30amp fuse (2) into the lower slot of the add-a-fuse harness (4).
19. Plug the add-a-fuse (4) into the now vacant slot.
20. Connect the 'ORANGE' power wire 1-way connector (5) into the add-a-fuse harness (6) mating connector.

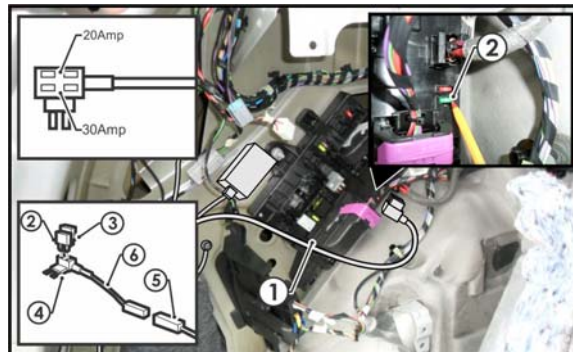

21. Route the trailer patch towards the RHS of the luggage compartment.

Wiring Loom Fitting Instructions To Suit Opel Astra Hatch / Wagon / Insignia Part Number 100906-WL

22. On the RHS of the luggage compartment, following the table below, connect the supplied ezy tap (1) to the existing vehicle wire (2), then connect the trailer patch terminal (3) to the ezy tap (1).

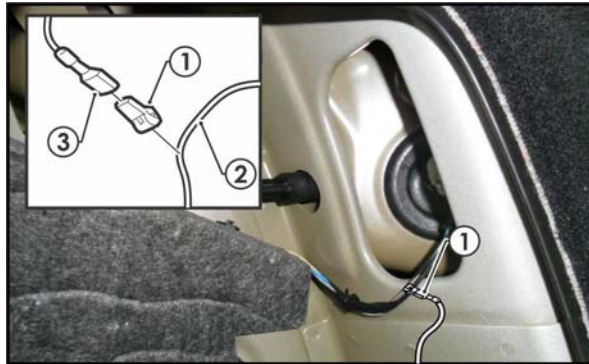

Function	Trailer Patch	Vehicle Connector
R.IND	GREEN / BLACK	BLUE / PURPLE

23. Mount the tail harness socket to the towbar mounting bracket using M4 fasteners (not supplied).
24. Route the tail harness up through the vehicle's grommet hole.
25. Ensure the tail harness grommet is seated correctly and secure in place using a cable tie (not supplied).
26. Connect the tail harness (tail length 1800mm) 8-way connector to the trailer harness mating 8-way connector.
27. Test the trailer harness function using a light board or multimeter.
28. Secure all harness using cable ties (not supplied).
29. Re-fit all removed parts and secure all fasteners, ensuring there are no squeaks or rattles.
30. Place instructions in glove box after fitment.

Wiring Loom Fitting Instructions To Suit Opel Astra Hatch / Wagon / Insignia Part Number 100906-WL

The following steps are for Opel Astra Hatch models only. For Opel Astra Wagon, please refer to page 2. For Opel Insignia, please proceed to page 8.

1. In the luggage compartment, remove the parcel shelf and the floor carpet cover.
2. Remove the rear luggage compartment trim.
3. Fold the rear passenger seat backrest.
4. On the LHS of the rear passenger side, remove the door trim.
5. Remove the LHS rear luggage compartment trim panel.
6. On the LHS of the luggage compartment trim, remove the clip and disconnect the light connector.

Repeat steps 4 - 6 for the RHS.

7. On the LHS luggage compartment, drill out the existing vehicle grommet to Ø30mm.
8. File any rough or sharp edges and spray rust inhibitor.
9. On the rear of the tail light, following the table below, connect the supplied ezy taps (1) to the existing vehicle wire (2), then connect the trailer patch terminals (3) to the ezy taps (1).

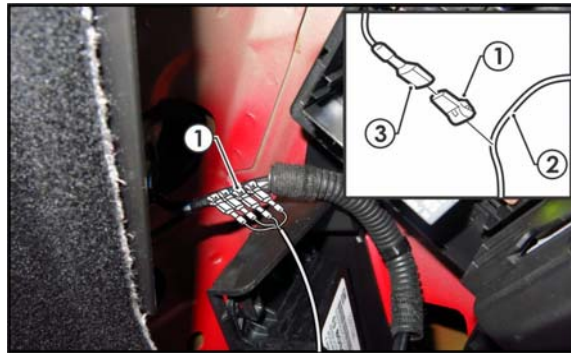

Function	Trailer Patch	Vehicle Connector
L.IND	YELLOW / BLACK	BLUE / WHITE
REVERSE	BLACK / WHITE	GREEN / WHITE
TAIL	BROWN / BLACK	PURPLE / GREY
BRAKES	RED / BLACK	GREY / YELLOW

10. Connect the trailer patch 12-way connector to the ECU.
11. Apply the double sided tape to the ECU and adhere it onto a suitable location on the sheet metal.
12. Using a tek screw, secure the trailer patch ground ring terminal to the sheet metal in a suitable location.

TRAILBOSS

Wiring Loom Fitting Instructions To Suit Opel Astra Hatch / Wagon / Insignia Part Number 100906-WL

13. Route the 'ORANGE' power wire (1) along the LHS of the luggage compartment towards the fuse panel.
14. Locate and remove the vehicle 30amp fuse (2).
15. Insert the supplied 20amp fuse (3) into the upper slot of the add-a-fuse harness (4).
16. Insert the previously removed 30amp fuse (2) into the lower slot of the add-a-fuse harness (4).
17. Plug the add-a-fuse (4) into the now vacant slot.
18. Connect the 'ORANGE' power wire 1-way connector (5) into the add-a-fuse harness (6) mating connector.

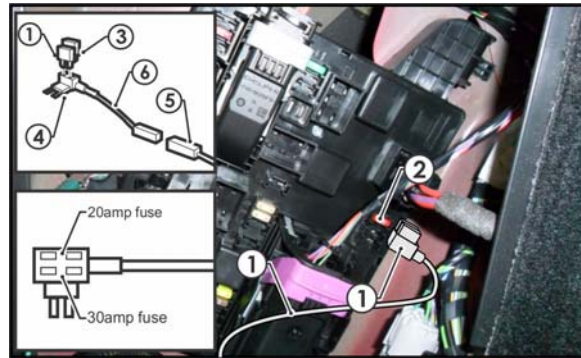

19. Route the trailer patch towards the RHS of the luggage compartment.
20. On the RHS of the luggage compartment, following the table below, connect the supplied ezy tap (1) to the existing vehicle wire (2), then connect the trailer patch terminal (3) to the ezy tap (1).

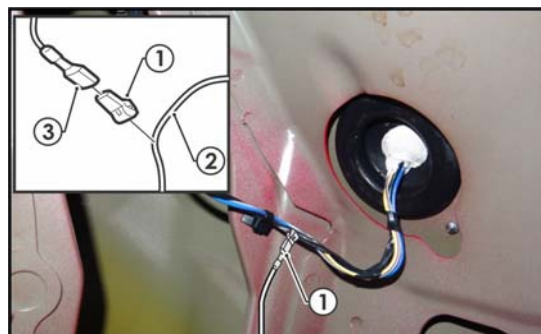

Function	Trailer Patch	Vehicle Connector
R.IND	GREEN / BLACK	BLUE / PURPLE



Wiring Loom Fitting Instructions
To Suit Opel Astra Hatch / Wagon / Insignia
Part Number 100906-WL

21. Mount the tail harness socket to the towbar mounting bracket using M4 fasteners (not supplied).
22. Route the tail harness up through the vehicle's grommet hole.
23. Ensure the tail harness grommet is seated correctly and secure in place using a cable tie (not supplied).
24. Connect the tail harness (tail length 1800mm) 8-way connector to the trailer harness mating 8-way connector.
25. Test the trailer harness function using a light board or multimeter.
26. Secure all harness using cable ties (not supplied).
27. Re-fit all removed parts and secure all fasteners, ensuring there are no squeaks or rattles.
28. Place instructions in glove box after fitment.

Wiring Loom Fitting Instructions To Suit Opel Astra Hatch / Wagon / Insignia Part Number 100906-WL

The following steps are for Opel Insignia Sport Tourer models only. For Opel Astra Wagon, please refer to page 2. For Opel Astra Hatch, please refer to page 5.

1. In the luggage compartment, remove the parcel shelf and the floor carpet cover.
2. Remove the rear luggage compartment trim by removing the two screws.
3. On the LHS upper luggage compartment trim, remove the two clips.
4. Remove the upper luggage compartment trim.
5. Remove the two screws and the access panel from the LHS lower luggage compartment trim.
6. Dislodge the LHS lower luggage compartment trim.

Repeat steps 3 – 6 for the RHS.

7. On the LHS of the rear quarter panel, using the existing vehicle grommet, drill out a Ø30mm hole.
8. On the LHS of the luggage compartment, following the table below, connect the supplied ezy taps (1) to the existing vehicle wires (2), then connect the trailer patch terminals (3) to the ezy taps (1).

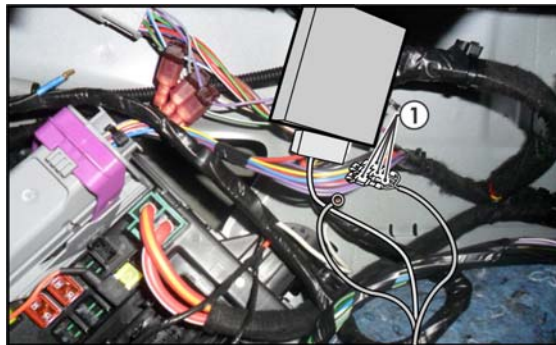

Function	Trailer Patch	Vehicle Connector
L.IND	YELLOW / BLACK	BLUE / WHITE
REVERSE	BLACK / WHITE	GREEN / WHITE
TAIL	BROWN / BLACK	PURPLE / GREY
BRAKES	RED / BLACK	GREY / YELLOW

9. Connect the trailer patch 12-way connector to the ECU.
10. Apply the double sided tape to the ECU and adhere it onto a suitable location on the sheet metal.
11. Secure the trailer patch ground ring terminal to the vehicle grounding point.

TRAILBOSS

Wiring Loom Fitting Instructions To Suit Opel Astra Hatch / Wagon / Insignia Part Number 100906-WL

12. Locate and remove the vehicle 20amp fuse (1).
13. Insert the supplied 20amp fuse (1) into the upper slot of the add-a-fuse harness (2).
14. Insert the previously removed 20amp fuse (3) into the lower slot of the add-a-fuse harness (2).
15. Plug the add-a-fuse (2) into the now vacant slot.
16. Connect the 'ORANGE' power wire 1-way connector (4) into the add-a-fuse harness (5) mating connector.

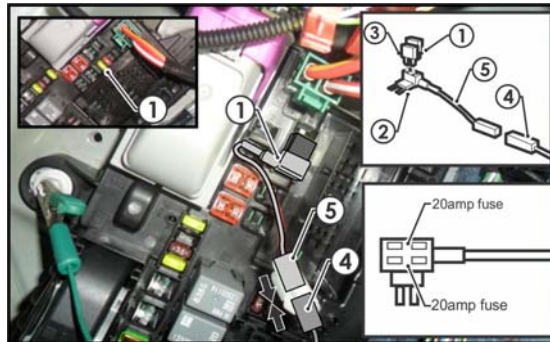

17. Route the trailer patch towards the RHS of the luggage compartment.
18. On the RHS of the luggage compartment, following the table below, connect the supplied ezy tap (1) to the existing vehicle wire (2), then connect the trailer patch terminal (3) to the ezy tap (1).

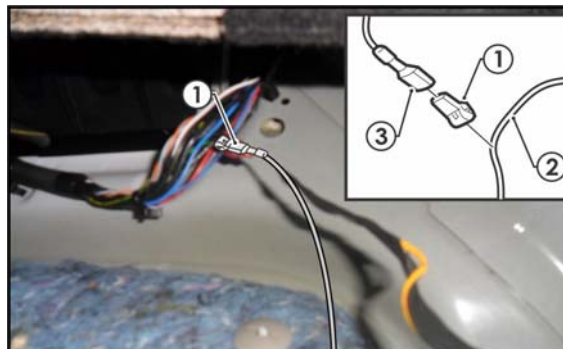

Function	Trailer Patch	Vehicle Connector
R.IND	GREEN / BLACK	BLUE / PURPLE



Wiring Loom Fitting Instructions
To Suit Opel Astra Hatch / Wagon / Insignia
Part Number 100906-WL

19. Mount the tail harness socket to the towbar mounting bracket using M4 fasteners (not supplied).
20. Route the tail harness up through the vehicle's grommet hole.
21. Ensure the tail harness grommet is seated correctly and secure in place using a cable tie (not supplied).
22. Connect the tail harness (tail length 1800mm) 8-way connector to the trailer harness mating 8-way connector.
23. Test the trailer harness function using a light board or multimeter.
24. Secure all harness using cable ties (not supplied).
25. Re-fit all removed parts and secure all fasteners, ensuring there are no squeaks or rattles.
26. Place instructions in glove box after fitment.