



Towbar Fitting Instructions
To Suit Toyota Tarago with step 03-2006-ON
Part Number QT1108
Rating 1600 kg

NOTE: Fitment does not require Factory Fitted Sonar to be deactivated on GLX.

WARNING:

1. Do not, drill, cut, weld or otherwise modify the tow bar.
2. If you are using electric welding on a motor vehicle, **always** check that the vehicle is not equipped with electronic engine or instrument management equipment. Failure to do so could **destroy** any onboard computers. If in doubt, check with the vehicle's manufacturer.

1. Ensure all hardware items have been included.
2. Remove the bumper bar skin via.
 - a. Remove the two bolts in recess of the rear door.
 - b. Remove the two screws from the inside of the LH and RH wheel arch.
 - c. Remove five clips securing the lower edge of the bumper to the vehicle.
 - d. Remove the parking sonar harness located behind the rear bumper (if fitted).
3. Remove the exhaust from the hanger.
4. Using a sharp knife, trim inner panel from the RH side of the bumper bar skin and discard.
5. Trim the bumper using the templates provided.
6. Refit bumper loosely initially before maneuvering towbar, and then fit bumper in reverse of steps 2 & 3.
7. Maneuver towbar to the chassis sub frame so that the holes in the side arms of the tow bar align with the captive nuts in the chassis rails.
8. Fasten all hardware loosely as per diagram below then tighten all hardware to torque listing.

NOTE: Trailboss recommends that you check your towball to ensure it complies with the Australian standard AS 4177.2.

RECOMMENDED ASSEMBLY TORQUE LISTING

Diameter	Grade 8.8 Bolt
	Nm;
M6	9.5
M8	21.7
M10	43.4
M12	77.3
M16	189.8

FOR TOWING PURPOSES ONLY
For towing capacity details please refer to vehicle owner's manual or to the manufacturer. Overloading can void your warranties.

Towbar Fitting Instructions
To Suit Toyota Tarago with step 03-2006-ON
Part Number QT1108
Rating 1600 kg

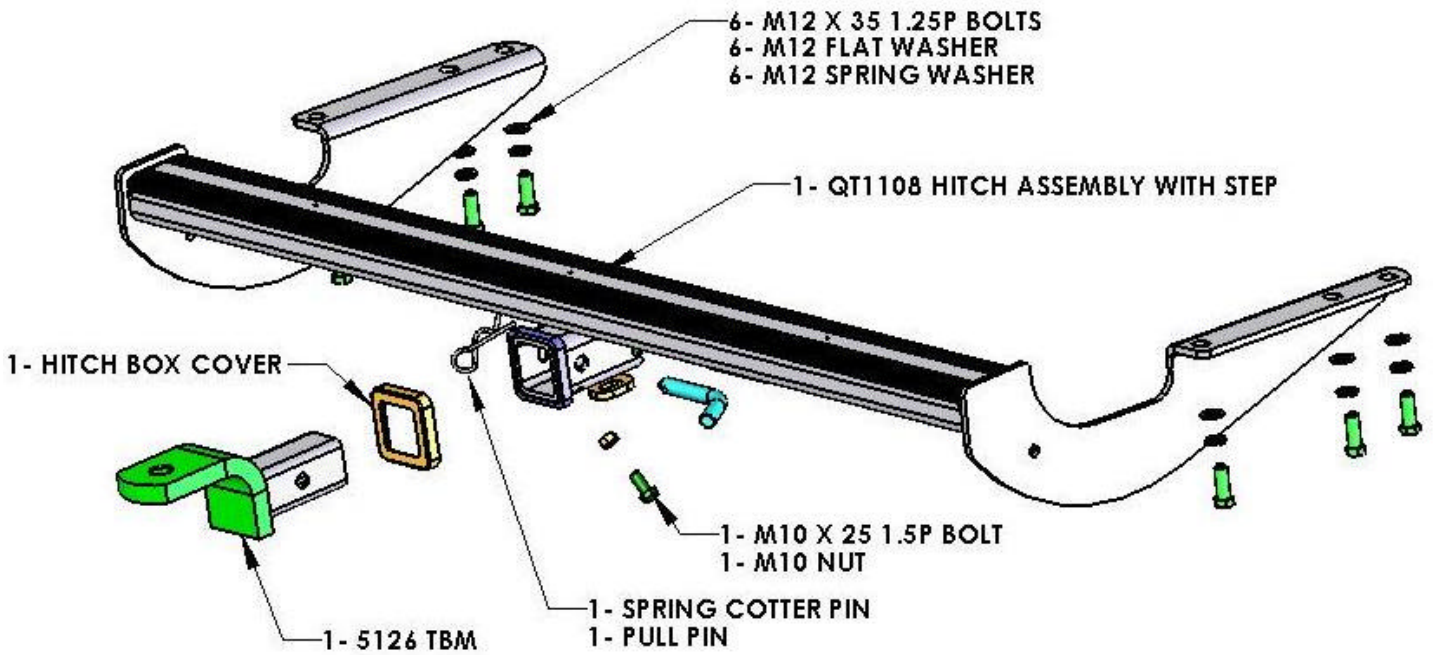

FIG 1: PASSENGER SIDE BUMPER CUT-OUT



FIG 2: DRIVER SIDE BUMPER CUT-OUT



Passenger & driver bumper cut-outs are shown.
Use the templates in the next two pages for
bumper cuts



QT1108-TO SUIT TOYOTA TARAGO 03-2006-

**IMPORTANT INFORMATION
USE THIS TEMPLATE TO CUT THE LH SIDE OF THE
BUMPER**

- STEP 1. Ensure that all dimensions are to scale before proceeding.
- STEP 2. Position the template on the inside of the rear bumper (unpainted surface)
- STEP 3. Align "edge of bumper" on template with the lowest edge on the rear bumper.
- STEP 4. Mark centre of 20mm holes.
- STEP 5. Cut 2 x 20mm holes using a 20mm Speedbore.
- STEP 6. Mark inside of bumper cover from edge mark (Step 4) to tangent of 20mm Holes (A to B, E to F and C to D).
- STEP 7. Use a sharp knife to cut along lines marked in step 6.



QT1108-TO SUIT TOYOTA TARAGO 03-2006-



IMPORTANT INFORMATION USE THIS TEMPLATE TO CUT THE RH (DRIVER'S) SIDE OF THE BUMPER

- STEP 1. Ensure that all dimensions are to scale before proceeding.
- STEP 2. Position the template on the inside of the rear bumper (unpainted surface)
- STEP 3. Align "edge of bumper" on template with the lowest edge on the rear bumper.
- STEP 4. Mark centre of 20mm holes.
- STEP 5. Cut 2 x 20mm holes using a 20mm Speedbore.
- STEP 6. Mark inside of bumper cover from edge mark (Step 4) to tangent of 20mm Holes (A to B, E to F and C to D).
- STEP 7. Use a sharp knife to cut along lines marked in step 6.

