

TRAILBOSS

Towbar Fitting Instructions To Suit TOYOTA RAV4 2013 ON Part Number QT1120L Rating 1500/150 kg

PLACE THESE INSTRUCTIONS IN THE VEHICLE'S GLOVEBOX AFTER INSTALLATION IS COMPLETED

WARNING:

1. Do not, drill, cut, weld or otherwise modify the tow bar.
2. If you are using electric welding on a motor vehicle, **always** check that the vehicle is not equipped with electronic engine or instrument management equipment. Failure to do so could **destroy** any onboard computers. If in doubt, check with the vehicle's manufacturer.
3. The high tensile fasteners supplied with this product were used to achieve the specified rating. If replacement is required ensure that fasteners of the same rating & quality are used. Contact an authorised **Trailboss** dealer if further information is required.

General:

1. Ensure all hardware items have been included refer to assembly diagram.
2. It is recommended that the instructions are read through and completely understood before making any attempt to fit this product.
3. Be wary of any changes to vehicle designs or other accessories that may conflict with the installation of this product.
4. Before drilling ensure that the area is clear of fuel, electrical & other components.
5. All holes drilled into the body panels shall have all burrs & swarf removed then coated with a suitable rust preventative paint.
6. For vehicles that require the bumper to be cut. Ensure cut out area is in correct position on the vehicle prior to cutting the bumper.
7. The high tensile fasteners supplied with this product were used to achieve the specified rating. If replacement is required ensure that fasteners of the same rating & quality are used. Contact an authorized **Trailboss** dealer if further information is required.
8. Ensure that all hardware is fastened to torque list below check fasteners on regular basis.
9. Tow bar load rating sticker provided with this product shall be conspicuously located on inside rear end of the driver's door. **(See diagram below)**.
10. Trailboss recommends that you check your tow ball to ensure that it complies with the Australian standards **AS 4177.2**.
11. **PLEASE NOTE:** It is advised to remove your lug or tbm when not actually towing so as to produce a clear view of the vehicles registration plate if obscured, and to also provide maximum available departure angle
12. Pull Pin must be fit in down position.

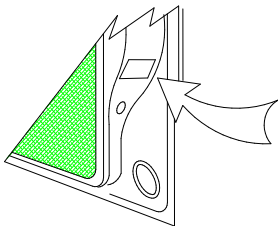

Place load rating sticker
inside driver's door here

FOR TRAILER TOWING PURPOSES ONLY
For towing capacity details please refer to vehicle owner's manual or to the manufacturer. Overloading can void your warranties.

RECOMMENDED ASSEMBLY TORQUE LISTING

Diameter	Grade 8.8 Bolt
M6	9.5 Nm
M8	21.7 Nm
M10	43.4 Nm
M12	77.3Nm
M14	146 Nm
M16	189.8 Nm

Tow bar Maintenance and Care.

Trailboss recommends that bolt torque's, as listed below, are routinely and regularly inspected and checked for correct tension. Replace any worn or defective parts.

We recommended to remove Tow Ball Mounts (TBM's, tongues or lugs) when not being used for any considerable length of time.

So as to avoid injury, when not towing it is suggested that the tongue, Pull Pin and R-clip are removed then stored in a safe, clean and dry place, away from excessive moisture.

Hitch Pull Pins and spring "R" clips are regularly checked for proper installation. Replace any worn or defective parts.

TRAILBOSS

Towbar Fitting Instructions
 To Suit **TOYOTA RAV4 2013 ON**
 Part Number **QT1120L**
 Rating **1500/150 kg**

PLACE THESE INSTRUCTIONS IN THE VEHICLE'S GLOVEBOX AFTER INSTALLATION IS COMPLETED

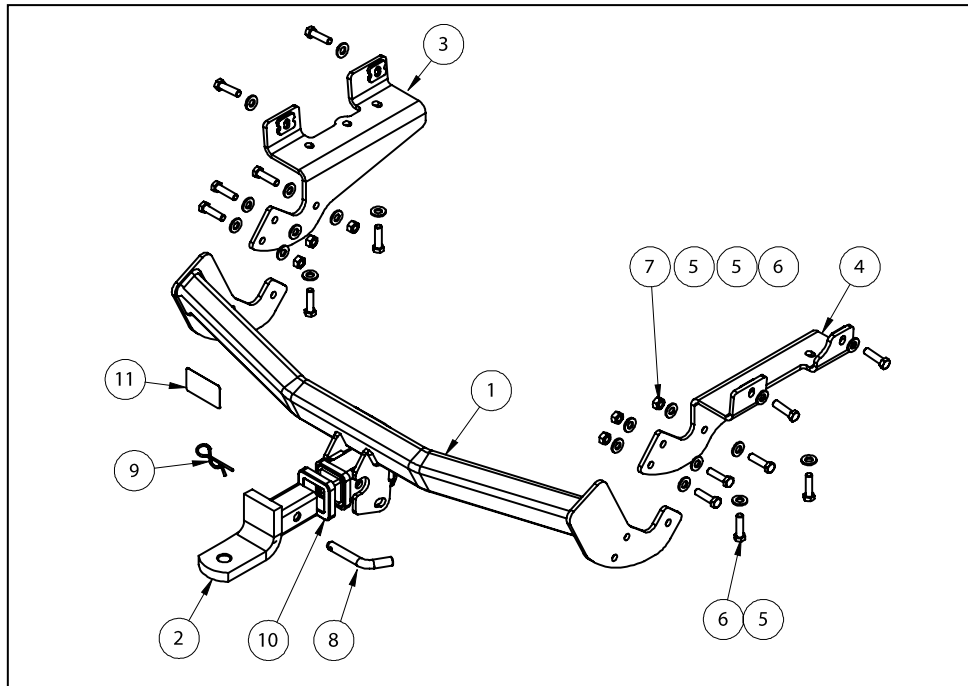

QTY.	DESCRIPTION	ITEM NO.
1	TOYOTA RAV-4 WELDED ASSEMBLY	1
1	CLASS 4 TBM	2
1	SIDEARM ASSEMBLY LHS	3
1	SIDEARM ASSEMBLY RHS	4
20	WASHER FLAT 1/2"	5
14	SET SCREW M12-1.25x45mm	6
6	M12x1.25 HEX NUT PC8	7
1	PULL PIN	8
1	R CLIP	9
1	HITCH BOX COLLAR COVER	10
1	ACRYLIC CP LABEL	11

ADDITIONAL ITEMS



WIRING LOOM



LR LABEL



FITTING INSTRUCTION

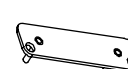

PLUG BRACKET



NUT NYLOC



BUMPER TRIM

TRAILBOSS

Towbar Fitting Instructions
To Suit **TOYOTA RAV4 2013 ON**
Part Number **QT1120L**
Rating **1500/150 kg**

PLACE THESE INSTRUCTIONS IN THE VEHICLE'S GLOVEBOX AFTER INSTALLATION IS COMPLETED

INSTRUCTION:

1. Remove 1x Screw in Wheel Arch on both sides.
2. Remove under tray by first removing 6x Scrivets.
3. Remove Bumper by releasing the Clips on the sides and firmly pulling backwards .
4. Remove impact beam (6x Bolts) and discard.
5. Remove shipping hook (2x Bolts)
6. Loosely bolt both Side Arms to Chassis using 2x M12 Bolts and Washers horizontally.
7. Bolt the centre section to the Side Arms using 3x M12 Bolt, 6x Washers & 3x M12 Nuts on both sides.
8. Fit the remaining M12 Bolts and Washers to the underside of the Chassis and torque all bolts to specifications provided on the first page.
9. Cut out Bumper section as shown.
10. Refit all parts in reverse order.





Wiring Loom Fitting Instructions
To Suit Toyota Rav 4
Part Number 100945-WL

Wiring Loom Installation Instructions

Toyota Rav 4

Part No: 100945-WL
ECU Required: 04826

Tail Harness Length Required: 1800mm

Wiring Loom Installation Time: Approx 30 Mins

Wiring Loom Fitting Instructions To Suit Toyota Rav 4 Part Number 100945-WL

1. In the luggage compartment, remove the floor carpet cover.
2. On the LHS of the luggage compartment, remove the tool tray.
3. Remove LHS trim cover.
4. Remove the rear luggage compartment trim.
5. On the LHS of the luggage compartment, remove the four screws securing the lower luggage compartment trim.
6. On the LHS rear passenger side, remove the door trim.
7. In the luggage compartment, remove rear seat trim cover by removing the two screws.
8. On the rear passenger seat, remove the three bolts and disconnect the seat connector.
9. Remove the rear passenger seat.
10. Remove the rear LHS seat belt bolt.
11. Remove the LHS lower luggage compartment trim and disconnect the light connector.
12. Remove the LHS upper luggage compartment trim.
13. On the LHS rear quarter panel of the luggage compartment, drill out the existing vehicle grommet to $\text{\O}30\text{mm}$ (1).

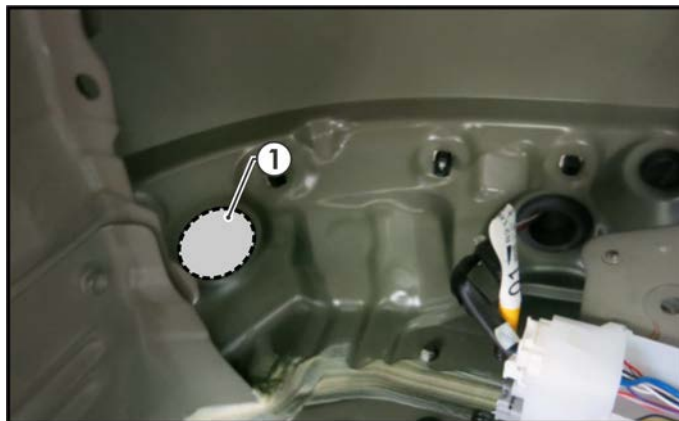

14. On the LHS of the luggage compartment, locate the vehicle breakout connector.
15. Connect the trailer patch to the vehicle break out connector.
16. Connect the trailer patch 12-way connector to the ECU.



Wiring Loom Fitting Instructions
To Suit Toyota Rav 4
Part Number 100945-WL

17. Apply the double sided tape to the ECU and adhere it onto a suitable location on the sheet metal.
18. Secure the trailer patch ground ring terminal to the vehicle grounding point.
19. Mount the tail harness socket to the towbar mounting bracket using M4 fasteners (not supplied).
20. Route the tail harness up through the LHS vehicle's grommet hole.
21. Ensure the tail harness grommet is seated correctly and secure in place using a cable tie (not supplied).
22. Connect the tail harness (tail length 1800mm) 8-way connector to the trailer harness mating 8-way connector.
23. Test the trailer harness function using a light board or multimeter.
24. Secure all harness using cable ties (not supplied).
25. Re-fit all removed parts and secure all fasteners, ensuring there are no squeaks or rattles.
26. Place instructions in glove box after fitment.