

TRAILBOSS

Towbar Fitting Instructions
To Suit **TOYOTA HIACE SLWB 04-2005 ON**
Part Number **QT1123L**
Rating **1400/140 kg**

PLACE THESE INSTRUCTIONS IN THE VEHICLE'S GLOVEBOX AFTER INSTALLATION IS COMPLETED

WARNING:

1. Do not, drill, cut, weld or otherwise modify the tow bar.
2. If you are using electric welding on a motor vehicle, **always** check that the vehicle is not equipped with electronic engine or instrument management equipment. Failure to do so could **destroy** any onboard computers. If in doubt, check with the vehicle's manufacturer.
3. The high tensile fasteners supplied with this product were used to achieve the specified rating. If replacement is required ensure that fasteners of the same rating & quality are used. Contact an authorised **Trailboss** dealer if further information is required.
4. If TBM is used in inverted position tow ball may make contact with rear tailgate when lowered, which could cause damage.

General:

1. Ensure all hardware items have been included refer to assembly diagram.
2. It is recommended that the instructions are read through and completely understood before making any attempt to fit this product.
3. Be wary of any changes to vehicle designs or other accessories that may conflict with the installation of this product.
4. Before drilling ensure that the area is clear of fuel, electrical & other components.
5. All holes drilled into the body panels shall have all burrs & swarf removed then coated with a suitable rust preventative paint.
6. For vehicles that require the bumper to be cut. Ensure cut out area is in correct position on the vehicle prior to cutting the bumper.
7. The high tensile fasteners supplied with this product were used to achieve the specified rating. If replacement is required ensure that fasteners of the same rating & quality are used. Contact an authorized **Trailboss** dealer if further information is required.
8. Ensure that all hardware is fastened to torque list below check fasteners on regular basis.
9. Tow bar load rating sticker provided with this product shall be conspicuously located on inside rear end of the driver's door. **(See diagram below).**
10. Trailboss recommends that you check your tow ball to ensure that it complies with the Australian standards **AS 4177.2**.
11. **PLEASE NOTE:** It is advised to remove your lug or tbn when not actually towing so as to produce a clear view of the vehicles registration plate if obscured, and to also provide maximum available departure angle
12. Pull Pin must be fit in down position.

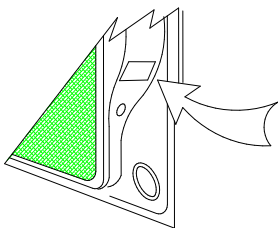

Place load rating sticker
inside driver's door here

FOR TRAILER TOWING PURPOSES ONLY
For towing capacity details please refer to vehicle owner's manual or to the manufacturer. Overloading can void your warranties.

RECOMMENDED ASSEMBLY TORQUE LISTING

Diameter	Grade 8.8 Bolt
M6	9.5 Nm
M8	21.7 Nm
M10	43.4 Nm
M12	77.3Nm
M14	146 Nm
M16	189.8 Nm

Tow bar Maintenance and Care.

Trailboss recommends that bolt torque's, as listed below, are routinely and regularly inspected and checked for correct tension. Replace any worn or defective parts.

We recommended to remove Tow Ball Mounts (TBM's, tongues or lugs) when not being used for any considerable length of time.

So as to avoid injury, when not towing it is suggested that the tongue, Pull Pin and R-clip are removed then stored in a safe, clean and dry place, away from excessive moisture.

Hitch Pull Pins and spring "R" clips are regularly checked for proper installation. Replace any worn or defective parts.

TRAILBOSS

Towbar Fitting Instructions
 To Suit **TOYOTA HIACE SLWB 04-2005 ON**
 Part Number **QT1123L**
 Rating **1400/140 kg**

PLACE THESE INSTRUCTIONS IN THE VEHICLE'S GLOVEBOX AFTER INSTALLATION IS COMPLETED

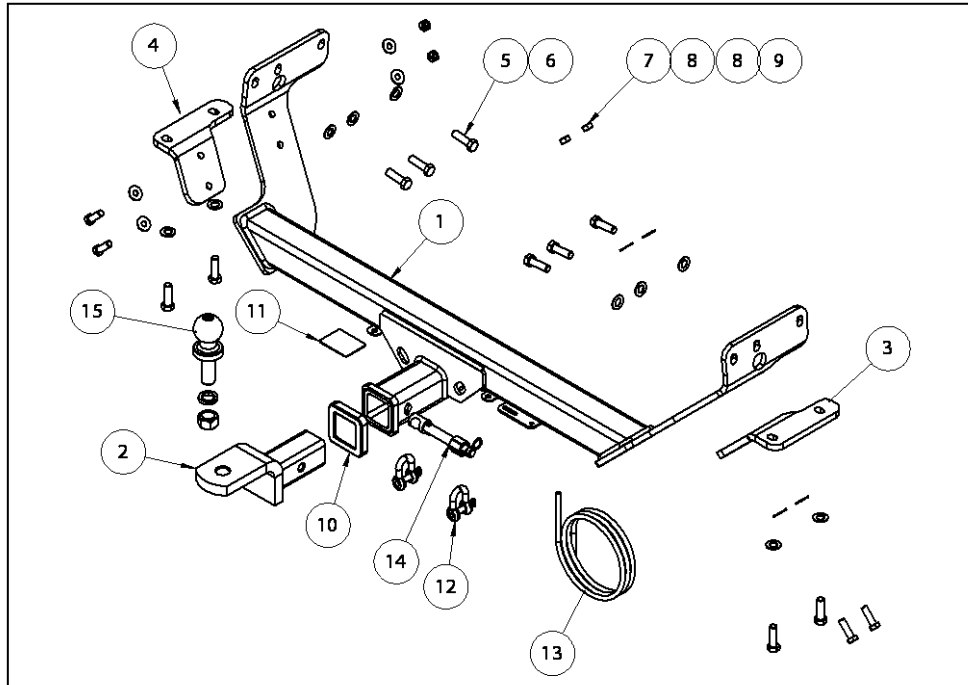

QTY.	DESCRIPTION	ITEM NO.
1	WELDED ASSY	1
1	TBM ASSY	2
1	MOUNT PLATE RHS	3
1	MOUNT PLATE LHS	4
10	BOLT M12X40 1.25P	5
10	WASHER FT 1/2"X1-1/8"X16 Z/P	6
4	SET SCREW M10-1.5X35mm	7
8	WASHER FT 3/8X1X16 BRT Z/P	8
4	HEX NUT M10X1.5	9
1	HITCH BOX COLLAR COVER	10
1	ACRYLIC COMPLIANCE PLATE	11
2	10mm "D" SHACKLE	12
1	WIRING LOOM	13
1	ANTI-RATTLE PULL PIN ASSY GOLD	14
1	50mm TOWBALL	15



Towbar Fitting Instructions
To Suit **TOYOTA HIACE SLWB 04-2005 ON**
Part Number **QT1123L**
Rating **1400/140 kg**

PLACE THESE INSTRUCTIONS IN THE VEHICLE'S GLOVEBOX AFTER INSTALLATION IS COMPLETED

INSTRUCTION:

1. Remove 4 x Push rivets from bumper tabs; discard two of the push rivets. Cut the two outermost bumper tabs.
2. Remove 4 x Screws securing bumper supports; discard the 4 Screws and the 4 bumper supports.
3. Offer Towbar to vehicle and loosely secure to chassis rail with 6 x M12x40 Bolts.
4. Loosely secure Mount Plates to underside of chassis rails using 4 x M12x40 Bolts. Loosely secure Mount Plates to main Towbar assembly using 4 off M10x35 Set Screws, complete with 2 x Flat Washers and 1 x Nut per Screw.
5. Tighten the 10 Bolts and 4 Set Screws to torque specified on page 1 of this document.
6. Connect remaining bumper tabs to tabs located on Towbar.



Wiring Loom Fitting Instructions
To Suit Toyota Hiace LWB & SLWB,
Hiace SLWB (April 2005 Onwards)
Part Number 100100-WL

Wiring Loom Installation Instructions

**Toyota Hiace LWB & SLWB,
Hiace SLWB (April 2005 Onwards)**

Part No: 100100-WL

**Tail Harness Length Required: 1200mm
RPA Override Switch Part No: 04848 (If Fitted)**

Wiring Loom Installation Time: Approx 30 Mins



Wiring Loom Fitting Instructions
To Suit Toyota Hiace LWB & SLWB,
Hiace SLWB (April 2005 Onwards)
Part Number 100100-WL

1. Remove the LHS and RHS tail light assemblies by removing the fasteners.
2. Underneath the vehicle near the RHS rear wheel arch, locate and remove the vehicle grommet but **do not discard**. Repeat for the opposite side.
3. Using a step drill, drill the grommet hole out to Ø26mm or just enough to fit the male 6-way connector through the grommet hole. File down any sharp edges and spray with rust inhibitor. Repeat for the opposite side.
4. Remove the tool trays by removing its fasteners.
5. Remove the fasteners from the RHS cargo area side trim and then remove the side trim and tail light cavity cover. Repeat for the LHS.
6. At the RHS, feed a guide wire through the grommet hole and then secure the Trailer Patch Harness (P/No: 100100-WL) to a guide wire. Route the Trailer Patch Harness through the grommet hole.
7. Cut a slit into the removed grommet and refit it over the Trailer Harness and secure back into the grommet hole.
8. Connect the RHS vehicle tail light connector to the Trailer Patch Harness (P/No:100100-WL) connector.
9. From underneath the vehicle, route the Trailer Patch Harness across to the LHS tail light cavity area.
10. At the LHS, feed a guide wire through the grommet hole and then secure the Trailer Patch Harness (P/No: 100100-WL) to a guide wire and then route the Trailer Patch Harness through the grommet hole.
11. Cut a slit into the removed grommet and refit it over the Trailer Harness and secure back into the grommet hole.
12. On the Tail Harness (Tail length:1200mm) 8-way male connector and 8-way female connector, apply electrical grease or silicon on to the back of the connectors to make them water proof.
13. Connect the Trailer Patch Harness 8-way female connector to the Tail Harness 8-way male connector.
14. Connect the LHS Trailer Patch Harness connector to the tail light assembly and then refit the tail light assembly. Repeat for the RHS.
15. Mount the Trailer socket on to the towbar mounting bracket using M4 fasteners. Secure harness to towbar using cable ties (not supplied).
16. Test the Trailer socket using a light board or multi-meter.
17. Secure the all harnesses using cables ties (not supplied). Refit all removed parts and secure all fasteners. Place instructions in glove box after fitment.



FITTING INSTRUCTIONS

Silent Anti-Rattle Hitch Pin (PR0001)

• These fitting instructions are supplied to ensure understanding of how the HITCH PIN should be fitted and used correctly.

• Once installed, we recommend **ALL** instructions are kept and placed in the vehicle glove box.

NOTE: Routine maintenance and inspection of the towbar & HITCH PIN is required. Regularly inspect for wear and check the tightness of the Hitch Pin. Follow instructions below to retighten the nut when necessary.

***Do not tow with your vehicle if the R CLIP or the HITCH PIN is loose or missing. Replacement parts are available from your Pro Series Distributor.**

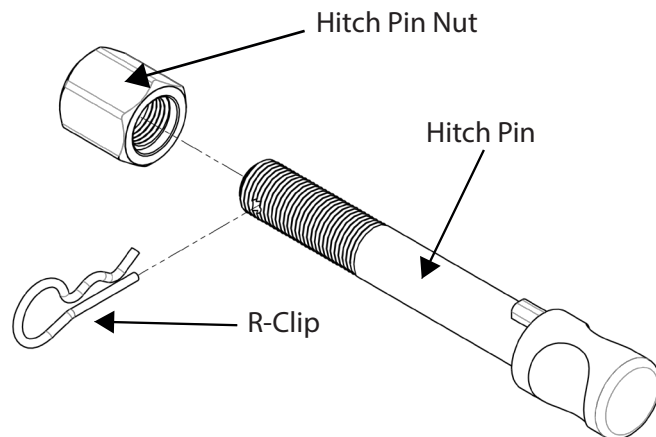

Fig 1. Silent Anti-Rattle Hitch Pin assembly

STEP 1

Insert Trailer Ball Mount (TBM) into towbar HITCHBOX, aligning hole in TBM SHANK with hole in HITCHBOX (Fig 2).

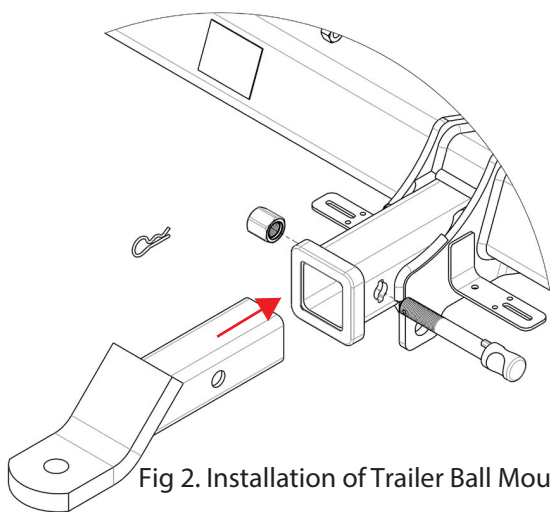

Fig 2. Installation of Trailer Ball Mount

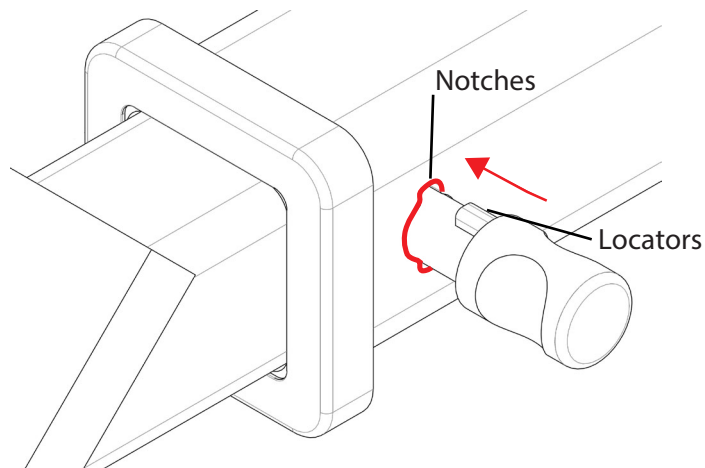

Fig 3. Silent Anti-Rattle Hitch Pin orientation

STEP 2

Insert HITCH PIN through hole in HITCHBOX and hole in TBM SHANK; ensure the LOCATORS are inserted into the NOTCHES in the HITCHBOX (Fig. 3).

STEP 3

Screw HITCH PIN NUT onto HITCH PIN ; tighten HITCH PIN NUT until finger tight, ensuring TBM is restrained from movement.

STEP 4

Tighten HITCH PIN NUT by turning nut a further 1/8th of a turn in the clockwise direction using a 24mm spanner (Fig. 4).

STEP 5

Install HITCH PIN R CLIP through the hole on the HITCH PIN (Fig. 1).

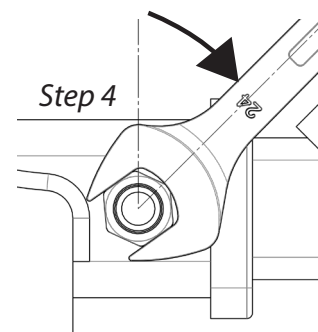

Fig 4. Tightening of Silent Anti-Rattle Hitch Pin Nut