



Towbar Fitting Instructions
To Suit Toyota Hilux Ute Bodies With Rear Step
Part Number QT555L

04 / 2005 – 08 / 2011 Rating 2250 kg - 225 kg
09 / 2011 onwards Rating 2500 kg - 250 kg

WARNING:

Do not, drill, cut, weld or otherwise modify the Towbar.

If you are using electric welding on a motor vehicle, **always** check that the vehicle is not equipped with electronic engine or instrument management equipment. Failure to do so could **destroy** any onboard **computers**. If in doubt, check with the vehicle's manufacturer.

1. Ensure all hardware items have been included.
2. Remove rear step from vehicle place step on suitable stands to support.
3. Remove side arms that support step each side.
4. Refit arms with 8mm packers provided each side.
5. Discard original bolts that fasten step to chassis rails 4 in total.
6. Offer Towbar to chassis rails aligning holes in side plates with captive nuts in chassis rails.
7. Fit M12 x 1.25 bolts flat & spring washers to front most mounting hole on each side of the side plate loosely.
8. Feed bolts on wire up chassis rails 2 per side then feed through existing holes.
9. Refit step sliding step forward to align holes in brackets with holes in side plates of Towbar then fasten with M12 x 1.25 bolts & flat & spring washers provided.
10. Fasten all bolts & nuts to torque listing below.
11. Trim excess wire off bolts on wire that have been fed down the chassis rails.
12. **Note T/BM 21177 to be in the DOWN position for 4x4 and in the UP position for 4x2 models.**

RECOMMENDED ASSEMBLY TORQUE LISTING

<u>Diameter</u>	<u>Grade 8.8 Bolt</u>	
	Nm	
M6	9.5	
M8	21.7	
M10	43.4	
M12	77.3	(M12 Grade 10.9 Bolt = 120 Nm)
M14	121.0	
M16	189.8	

TRAILBOSS

Towbar Fitting Instructions To Suit Toyota Hilux Ute Bodies With Rear Step **Part Number QT555L**

04 / 2005 – 08 / 2011 Rating 2250 kg - 225 kg
09 / 2011 onwards Rating 2500 kg - 250 kg

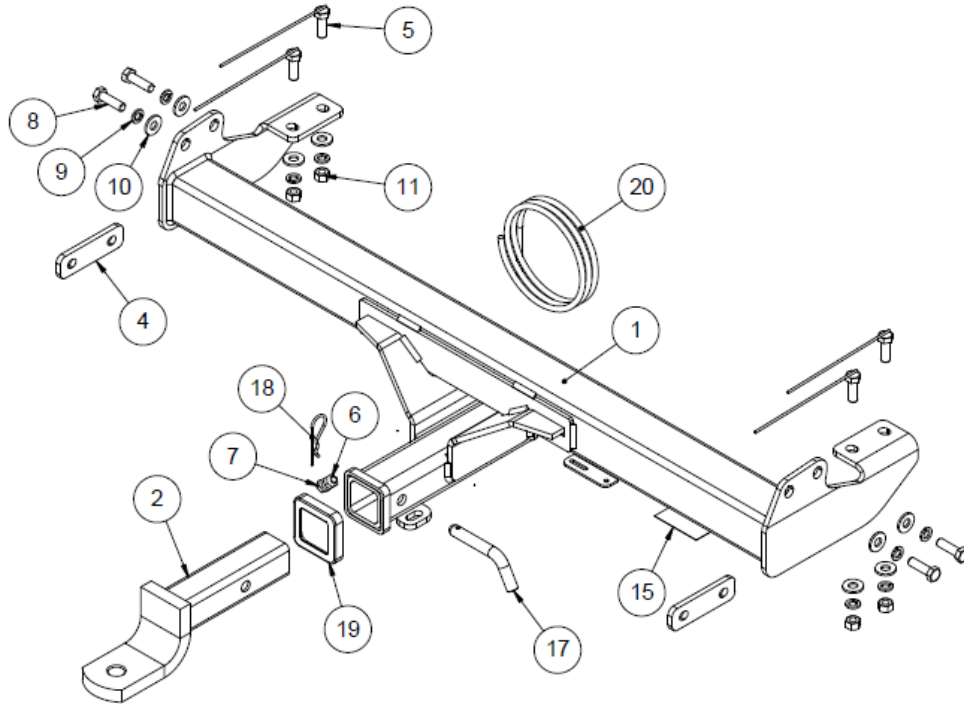

QTY.	DESCRIPTION	ITEM NO.
1	WELDED ASSEMBLY	1
1	TRAILER BALL MOUNT	2
1	BOLT PACK	3
2	LOOSE PLATE	4
4	BOLT & WIRE ASSEMBLY	5
1	M10x1.5 HEX NUT PC8	6
1	BOLT M10-1.50 x 25	7
4	BOLT M12 - 1.25 x 45mm Gr 10.9 Z/P	8
8	Wshr spring ft sec M12x4.0x2.5mm z/p	9
8	WASHER M12x28.8x3mm	10
4	M12x1.75 HEX NUT PC8	11
1	BRAND BAG ASSY	12
1	PLASTIC SHEET BAG 250x350	13
1	FITTING INSTRUCTION	14
1	ACRYLIC CP LABEL	15
1	ACRYLIC LR LABEL	16
1	PULL PIN	17
1	R CLIP	18
1	HITCH BOX COLLAR COVER	19
1	WIRING LOOM	20



Wiring Loom Fitting Instructions
To Suit Toyota Hilux
Hilux Cab Chassis & Tub Body – 4x4 & 4x2

Part Number 100002-WL

Wiring Loom Installation Instructions

**Toyota Hilux
Hilux Cab Chassis & Tub Body – 4x4 & 4x2**

Part No: 100002-WL

**Tail Harness Length Required: 1800mm
RPA Override Switch Part No: 04848 (If Fitted)**

Wiring Loom Installation Time: Approx 20 Mins



Wiring Loom Fitting Instructions
To Suit Toyota Hilux
Hilux Cab Chassis & Tub Body – 4x4 & 4x2

Part Number 100002-WL

1. Disconnect and remove the tail light on both sides of the vehicle by removing the two fasteners on each tail light assembly.
2. From underneath the vehicle, route the Trailer Patch Harness (P/No:100002-WL) connectors up the RHS tail light cavity.
3. Patch the Trailer Patch Harness RHS connectors in between the tail light connectors.
4. Refit the RHS tail light assembly.
5. Underneath the vehicle, route the Trailer Patch Harness over the support bar and along the vehicle harness towards the LHS tail light cavity.
6. Retrieve the Trailer Patch Harness connectors.
7. On the Tail Harness (length 1800mm) and mating connector, apply electrical grease or silicon on to the back of the connectors to make them water proof.
8. Connect the Trailer Patch Harness tail connector and the Tail Harness connector together.
9. Reconnect the LHS tail lights and refit the tail light assembly.
10. Mount the Tail Harness socket to the towbar mounting plate using M4 fasteners.
11. Test the Trailer socket using a light board or multi-meter.
12. Secure the all harnesses using cables ties (not supplied). Refit all removed parts and secure all fasteners. Place instructions in glove box after fitment.