

# TRAILBOSS

Towbar Fitting Instructions  
To Suit **BMW X5 04/2007-12/2010**  
Part Number **QTBM112L**  
Rating **2700/270 kg**

## **WARNING:**

1. Do not, drill, cut, weld or otherwise modify the tow bar.
2. If you are using electric welding on a motor vehicle, **always** check that the vehicle is not equipped with electronic engine or instrument management equipment. Failure to do so could **destroy** any onboard computers. If in doubt, check with the vehicle's manufacturer.

## **General:**

1. Ensure all hardware items have been included refer to assembly diagram.
2. It is recommended that the instructions are read through and completely understood before making any attempt to fit this product.
3. Be wary of any changes to vehicle designs or other accessories that may conflict with the installation of this product.
4. Before drilling ensure that the area is clear of fuel, electrical & other components.
5. All holes drilled into the body panels shall have all burrs & swarf removed then coated with a suitable rust preventative paint.
6. For vehicles that require the bumper to be cut. Ensure cut out area is in correct position on the vehicle prior to cutting the bumper.
7. The high tensile fasteners supplied with this product were used to achieve the specified rating. If replacement is required ensure that fasteners of the same rating & quality are used. Contact an authorized **Trailboss** dealer if further information is required.
8. Ensure that all hardware is fastened to torque list below check fasteners on regular basis.
9. Tow bar load rating sticker provided with this product shall be conspicuously located on inside rear end of the driver's door. **(See diagram below).**
10. Trailboss recommends that you check your tow ball to ensure that it complies with the Australian standards **AS 4177.2.**
11. **PLEASE NOTE:** It is advised to remove your lug or tbn when not actually towing so as to produce a clear view of the vehicles registration plate if obscured, and to also provide maximum available departure angle

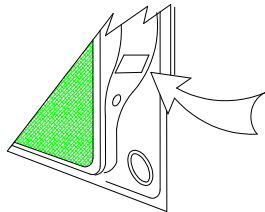

Place load rating sticker  
inside driver's door here

**FOR TOWING PURPOSES ONLY**  
For towing capacity details please refer to vehicle owner's manual or to the manufacturer. Overloading can void your warranties.

### **RECOMMENDED ASSEMBLY TORQUE LISTING**

Diameter    Grade 8.8 Bolt

M6	9.5 Nm
M8	21.7 Nm
M10	43.4 Nm
M12	77.3 Nm
M14	146 Nm
M16	189.8 Nm

## **Tow bar Maintenance and Care.**

Trailboss recommends that bolt torque's, as listed below, are routinely and regularly inspected and checked for correct tension. Replace any worn or defective parts.

We recommended to remove Tow Ball Mounts (TBM's, tongues or lugs) when not being used for any considerable length of time.

So as to avoid injury, when not towing it is suggested that the tongue, Pull Pin and R-clip are removed then stored in a safe, clean and dry place, away from excessive moisture.

Hitch Pull Pins and spring "R" clips are regularly checked for proper installation. Replace any worn or defective parts.



Towbar Fitting Instructions  
To Suit **BMW X5 04/2007-12/2010**  
Part Number **QTBM112L**  
Rating **2700/270 kg**

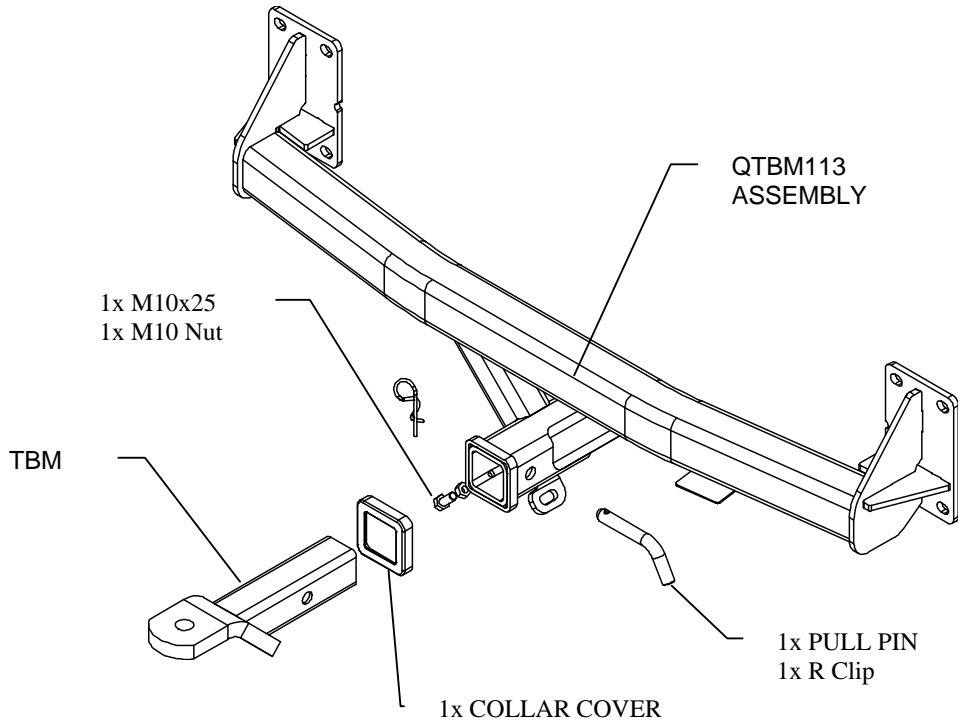

1. Remove taillights, 3 x M8 nuts per side.
2. Remove mud flaps 3 x plastic rivets, 3 self taper 1x plastic trim button
3. Pull back plastic where flare to expose 1x hex self taper and 1x torx self taper remove.
4. Remove bottom bumper trim panel 2x Phillips lock screw's and unclip all location tag's
5. From under car, remove 4x hex self tapers holding heat shield to plastic bumper support frame
6. Remove 5x hex self taper holding bumper support frame to body frame
7. Remove bumper disconnect sensor's, from the side pull bumper skin away from the vehicle to release bumper from the side of vehicle.
8. Remove and discard impact beam but retaining factory nuts to be reuse.
9. Fit Towbar using factory nuts, torque all fasteners to specification.
10. Cut bumper support frame as per diagram below.
11. Cut bumper trim panel as per diagram below.

Towbar Fitting Instructions  
To Suit **BMW X5 04/2007-12/2010**  
Part Number **QTBM112L**  
Rating **2700/270 kg**

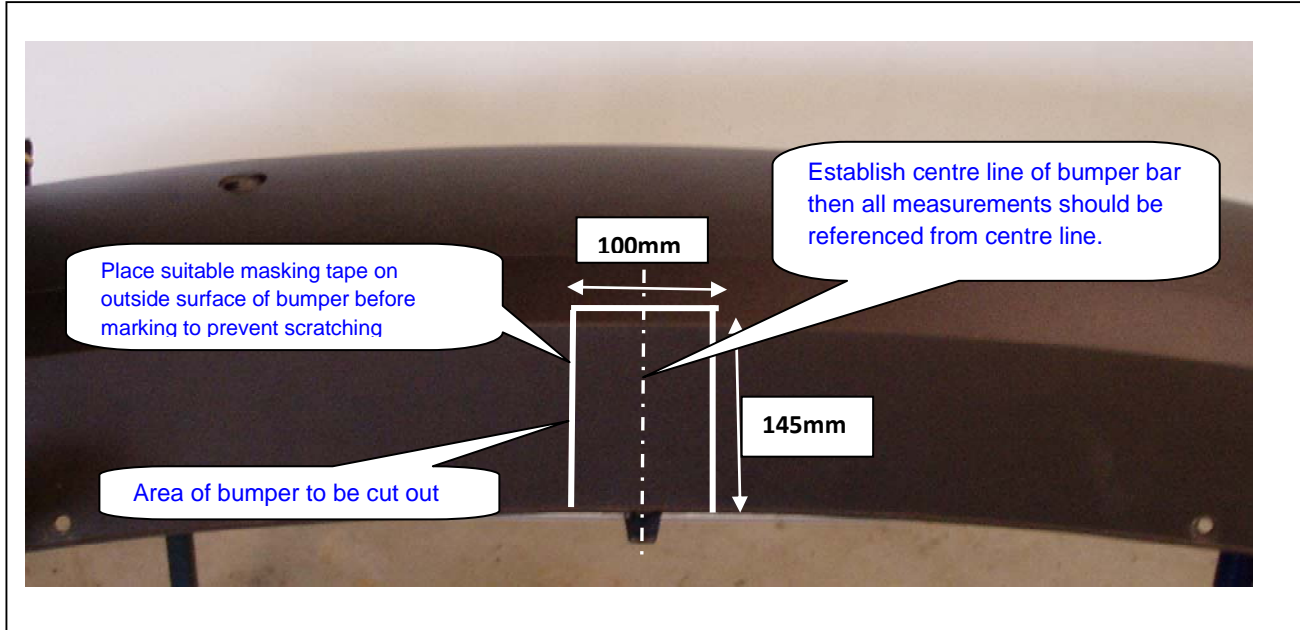

Cut OUTER bumper skin  
100 mm wide x 145 mm in height, from the centre line & edge of bumper skin.

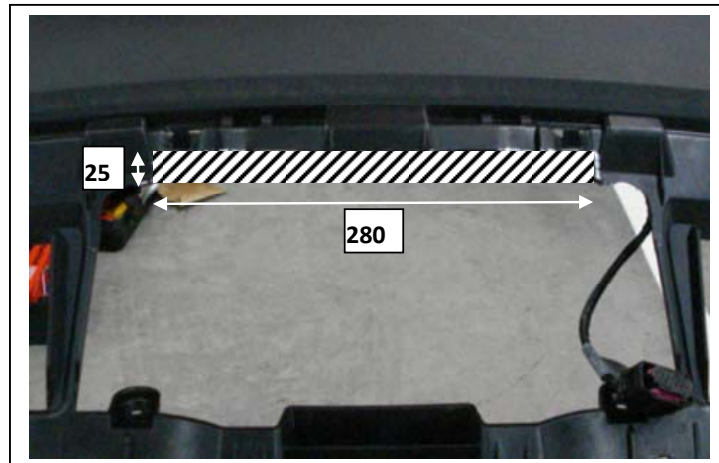

Cut bumper support frame  
280 mm wide x 25 mm in height, from the edge of open cavity.

Towbar Fitting Instructions  
To Suit **BMW X5 04/2007-12/2010**  
Part Number **QTBM112L**  
Rating **2700/270 kg**

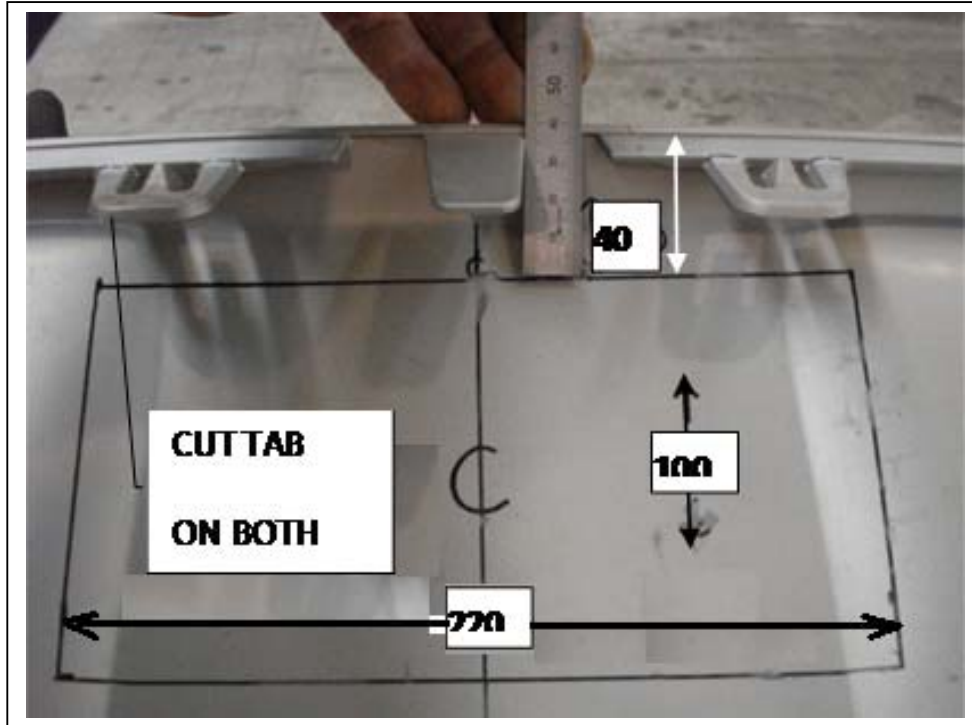

Cut tabs near centre portion. From the edge of the INNER panel measure 40mm

Cut 220 mm wide x 100 mm in height, equally spaced from centre line.



Towbar Fitting Instructions  
To Suit **BMW X5 04/2007-12/2010**  
Part Number **QTBM112L**  
Rating **2700/270** kg

### Wiring Loom Installation Instructions

**BMX X1, X5 & X6**  
Part No: 100707-WL

**ECU Required – 04828**  
**Tail Harness Length Required: 1800mm**  
**RPA Override Switch Part No: 04848 (If Fitted)**

**Wiring Loom Installation Time: Approx 50 Mins**



Towbar Fitting Instructions  
To Suit **BMW X5 04/2007-12/2010**  
Part Number **QTBM112L**  
Rating **2700/270 kg**

**BMX X**

1. In the luggage compartment, remove the floor carpet cover.
2. Remove the storage compartment tray.
3. Remove the rear trim by first removing the fasteners from the cargo hook tie-downs.
4. Remove the RHS access panel cover.
5. Route the trailer harness (P/No: 100707-WL) underneath the RHS side trim towards the RHS tail light assembly connector.
6. Remove the LHS storage compartment.
7. Underneath the LHS storage compartment remove the vehicle grommet.
8. Drill out the grommet hole to Ø31mm. File any rough or sharp edges and spray on rust inhibitor.
9. Following the table below, connect the ezy-taps to the vehicle harness wires, then connect the trailer harness terminals to the corresponding wires.

Function	Trailer Patch	Vehicle Connector
R.IND	GREEN / BLACK	BLUE / BROWN
REVERSE	BLACK / WHITE	BLACK / PURPLE
TAIL/BRAKE	BROWN / BLACK WITH X1 LABEL	BLACK / BLUE

10. Route the trailer harness across the rear of the luggage compartment towards the LHS of the vehicle.
11. Following the table below, connect the ezy-tap to the vehicle harness wire, then connect the trailer harness terminal to the corresponding wire.

Function	Trailer Patch	Vehicle Connector
L.IND	YELLOW / BLACK	BLUE / GREEN

12. Connect the trailer harness patch power ring terminal to the vehicle battery positive terminal.
13. Connect the trailer harness ground ring terminal to the vehicle battery negative terminal.
14. Connect the trailer harness 12-way connector to the ECU (No: 04282).
15. Slot the ECU into one of the vacant slots on the RHS foam compartment.
16. Route the tail harness (tail length 1800mm) through the previously drilled out grommet hole towards the towbar.



Towbar Fitting Instructions  
To Suit **BMW X5 04/2007-12/2010**  
Part Number **QTBM112L**  
Rating **2700/270 kg**

17. Mount the trailer socket to the towbar mounting bracket using M4 fasteners (not supplied).
18. Ensure the tail harness grommet is seated correctly and secured in place using a cable tie (not supplied).
19. Connect the trailer harness 8-way connector to the tail harness mating connector.
20. Test the Trailer socket using a light board or multi-meter.
21. Secure the all harnesses using cables ties (not supplied).
22. Re-fit all removed parts and secure all fasteners.
23. Place instructions in glove box after fitment.