

# TRAILBOSS

Towbar Fitting Instructions  
To Suit **MITSUBISHI TRITON D-CAB W/O STEP, C&S**  
Part Number **QTCL654L**  
Rating **3100/310 kg**

PLACE THESE INSTRUCTIONS IN THE VEHICLE'S GLOVEBOX AFTER INSTALLATION IS COMPLETED

## **WARNING:**

1. Do not, drill, cut, weld or otherwise modify the tow bar.
2. If you are using electric welding on a motor vehicle, **always** check that the vehicle is not equipped with electronic engine or instrument management equipment. Failure to do so could **destroy** any onboard computers. If in doubt, check with the vehicle's manufacturer.
3. The high tensile fasteners supplied with this product were used to achieve the specified rating. If replacement is required ensure that fasteners of the same rating & quality are used. Contact an authorised **Trailboss** dealer if further information is required.
4. If TBM is used in inverted position tow ball may make contact with rear tailgate when lowered, which could cause damage.

## **General:**

1. Ensure all hardware items have been included refer to assembly diagram.
2. It is recommended that the instructions are read through and completely understood before making any attempt to fit this product.
3. Be wary of any changes to vehicle designs or other accessories that may conflict with the installation of this product.
4. Before drilling ensure that the area is clear of fuel, electrical & other components.
5. All holes drilled into the body panels shall have all burrs & swarf removed then coated with a suitable rust preventative paint.
6. For vehicles that require the bumper to be cut. Ensure cut out area is in correct position on the vehicle prior to cutting the bumper.
7. The high tensile fasteners supplied with this product were used to achieve the specified rating. If replacement is required ensure that fasteners of the same rating & quality are used. Contact an authorized **Trailboss** dealer if further information is required.
8. Ensure that all hardware is fastened to torque list below check fasteners on regular basis.
9. Tow bar load rating sticker provided with this product shall be conspicuously located on inside rear end of the driver's door. **(See diagram below).**
10. Trailboss recommends that you check your tow ball to ensure that it complies with the Australian standards **AS 4177.2.**
11. **PLEASE NOTE:** It is advised to remove your lug or tbm when not actually towing so as to produce a clear view of the vehicles registration plate if obscured, and to also provide maximum available departure angle
12. Pull Pin must be fit in down position.

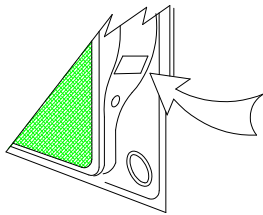

Place load rating sticker  
inside driver's door here

**FOR TRAILER TOWING PURPOSES ONLY**  
For towing capacity details please refer to vehicle owner's manual or to the manufacturer. Overloading can void your warranties.

### **RECOMMENDED ASSEMBLY TORQUE LISTING**

| Diameter | Grade 8.8 Bolt |
|----------|----------------|
| M6       | 9.5 Nm         |
| M8       | 21.7 Nm        |
| M10      | 43.4 Nm        |
| M12      | 77.3Nm         |
| M14      | 146 Nm         |
| M16      | 189.8 Nm       |

## **Tow bar Maintenance and Care.**

Trailboss recommends that bolt torque's, as listed below, are routinely and regularly inspected and checked for correct tension. Replace any worn or defective parts.

We recommended to remove Tow Ball Mounts (TBM's, tongues or lugs) when not being used for any considerable length of time.

So as to avoid injury, when not towing it is suggested that the tongue, Pull Pin and R-clip are removed then stored in a safe, clean and dry place, away from excessive moisture.

Hitch Pull Pins and spring "R" clips are regularly checked for proper installation. Replace any worn or defective parts.

# TRAILBOSS

Towbar Fitting Instructions  
 To Suit **MITSUBISHI TRITON D-CAB W/O STEP, C&S**  
 Part Number **QTCL654L**  
 Rating **3100/310 kg**

PLACE THESE INSTRUCTIONS IN THE VEHICLE'S GLOVEBOX AFTER INSTALLATION IS COMPLETED

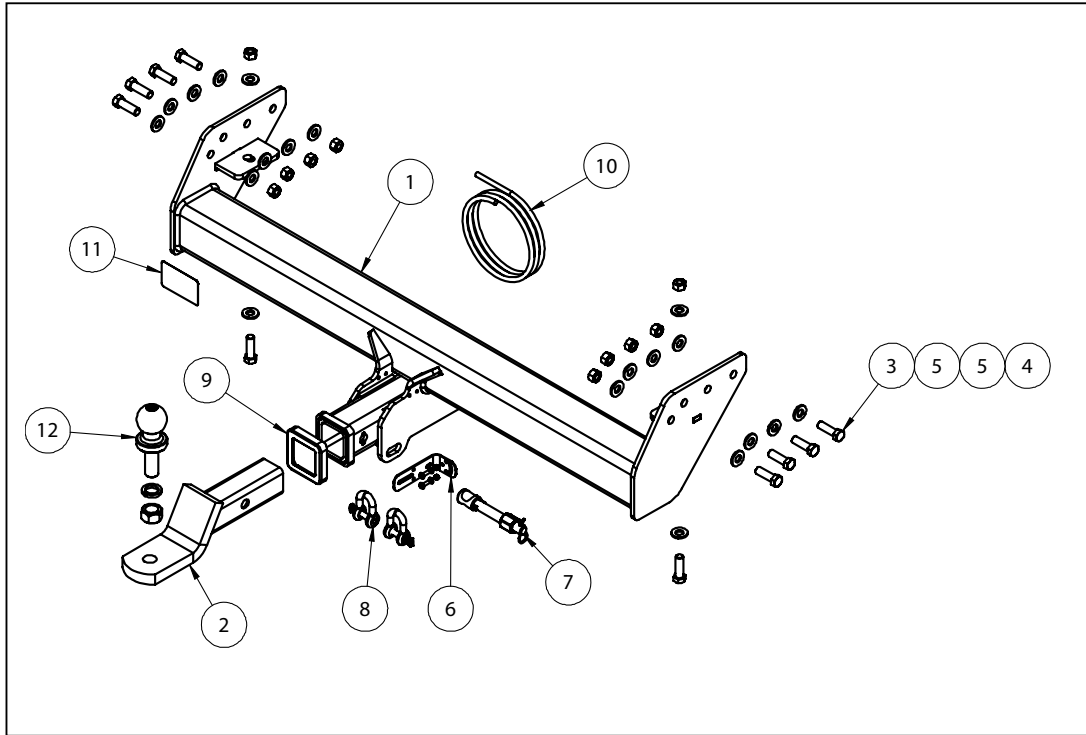

| QTY. | DESCRIPTION                  | ITEM NO. |
|------|------------------------------|----------|
| 1    | WELDED ASSY                  | 1        |
| 1    | TBM ASSEMBLY                 | 2        |
| 10   | SET SCREW M12-1.75X40        | 3        |
| 10   | HEX NUT PC8 M12X1.75         | 4        |
| 20   | WASHER FLAT 1/2" X1 1/8"X1/8 | 5        |
| 1    | UNIVERSAL PLUG BRACKET KIT   | 6        |
| 1    | SILENT HITCH PIN -SILVER     | 7        |
| 2    | 10 MM "D" SHACKLE            | 8        |
| 1    | HITCH BOX COLLAR COVER       | 9        |
| 1    | WIRING LOOM                  | 10       |
| 1    | ACRYLIC CP LABEL             | 11       |
| 1    | TOWBALL 50 MM                | 12       |



Towbar Fitting Instructions  
To Suit **mitsubishi triton d-cab w/o step, c&s**  
Part Number **QTCL654L**  
Rating **3100/310** kg

PLACE THESE INSTRUCTIONS IN THE VEHICLE'S GLOVEBOX AFTER INSTALLATION IS COMPLETED

**INSTRUCTION:**

1. Offer Towbar to vehicle and secure with 5 of sets M12 fasteners on both LH & RH side.
2. Tighten all fasteners with torque of 125Nm.



Wiring Loom Fitting Instructions  
To Suit Mitsubishi Triton (all models) Single Cab, Dual Cab  
Part Number 100006-WL

## Wiring Loom Installation Instructions

Mitsubishi Triton (all models)  
Single Cab, Dual Cab  
Part No: 100006-WL

Tail Harness Length Require: 1800mm

Wiring Loom Installation Time: Approx. 30 minutes.



Wiring Loom Fitting Instructions  
To Suit Mitsubishi Triton (all models) Single Cab, Dual Cab  
Part Number 100006-WL

**All instruction steps are applicable to current and previous models, single cab and dual cab.**

1. Underneath the rear LHS rear quarter of the vehicle tray, disconnect the LHS tail light connector.
2. Connect the Trailer Patch Harness connectors (P/No: 100006-WL) in between the tail light connectors. **Note: Depending on vehicle variation, the tail light connectors on the LHS chassis may be located before or after the spare wheel area.**
3. Connect the relays to the Trailer Patch Harness.
4. Add green secondary lock so that the connectors cannot come out.
5. Secure the relays and trailer patch ground ring terminal onto the chassis rail using a tek screw (not supplied).
6. On the Tail Harness (tail length 1800mm) and mating connector, apply electrical grease or silicon on to the back of the connectors to make them water proof.
7. Connect the Tail Harness to the Trailer Patch Harness.
8. Route the Trailer Patch Harness battery ring terminal wire along the LHS chassis rail following the vehicle body harness, all the way to the engine bay.
9. Secure with cable ties (not supplied) at every 200mm intervals. Ensure to keep harness away from any locations of extreme heat, moving parts or sharp objects.
10. In the engine bay, retrieve the Trailer Harness battery ring terminal wire.
11. Secure the Trailer Harness battery ring terminal onto the positive battery terminal.
12. At the rear of the vehicle, secure the Tail Harness socket onto the trailer socket mounting place using M4 fasteners (not supplied).
13. Test the trailer patch functions using a light board or multi-meter.
14. Secure all harnesses using cables ties (not supplied).
15. Refit all removed parts and secure all fasteners.
16. Place instructions in glove box after fitment.



# FITTING INSTRUCTIONS

## Silent Anti-Rattle Hitch Pin (PR0001)

• These fitting instructions are supplied to ensure understanding of how the HITCH PIN should be fitted and used correctly.

• Once installed, we recommend **ALL** instructions are kept and placed in the vehicle glove box.

**NOTE: Routine maintenance and inspection of the towbar & HITCH PIN is required. Regularly inspect for wear and check the tightness of the Hitch Pin. Follow instructions below to retighten the nut when necessary.**

**\*Do not tow with your vehicle if the R CLIP or the HITCH PIN is loose or missing. Replacement parts are available from your Pro Series Distributor.**

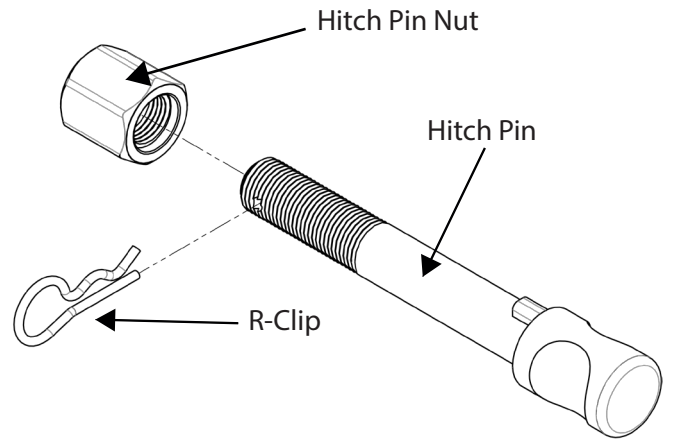

Fig 1. Silent Anti-Rattle Hitch Pin assembly

### STEP 1

Insert Trailer Ball Mount (TBM) into towbar HITCHBOX, aligning hole in TBM SHANK with hole in HITCHBOX (Fig 2).

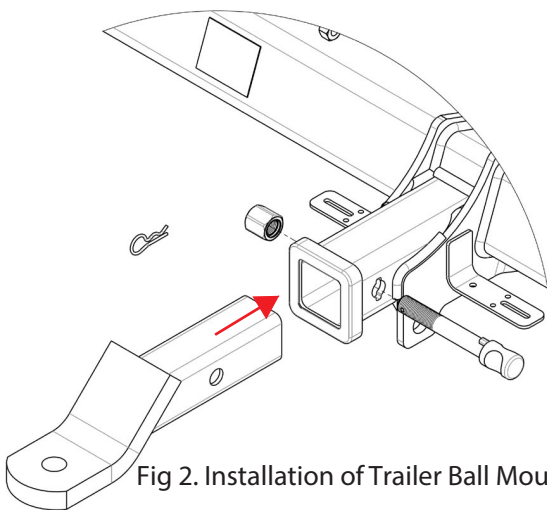

Fig 2. Installation of Trailer Ball Mount

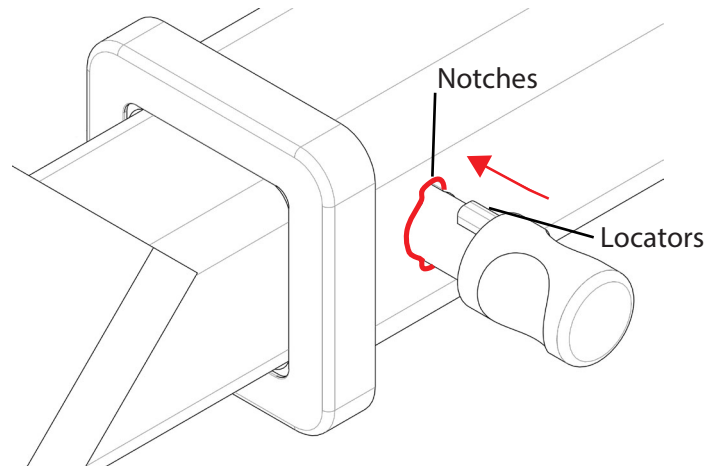

Fig 3. Silent Anti-Rattle Hitch Pin orientation

### STEP 2

Insert HITCH PIN through hole in HITCHBOX and hole in TBM SHANK; ensure the LOCATORS are inserted into the NOTCHES in the HITCHBOX (Fig. 3).

### STEP 3

Screw HITCH PIN NUT onto HITCH PIN; tighten HITCH PIN NUT until finger tight, ensuring TBM is restrained from movement.

### STEP 4

Tighten HITCH PIN NUT by turning nut a further 1/8th of a turn in the clockwise direction using a 24mm spanner (Fig. 4).

### STEP 5

Install HITCH PIN R CLIP through the hole on the HITCH PIN (Fig. 1).

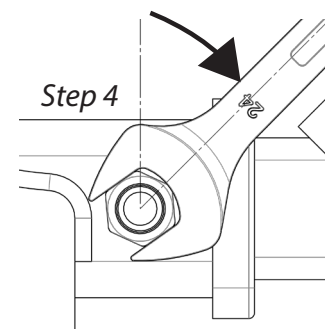

Fig 4. Tightening of Silent Anti-Rattle Hitch Pin Nut