

TRAILBOSS

Towbar Fitting Instructions
To Suit **MITSUBISHI PAJERO SPORT QE SERIES**
Part Number **QTCL655L**
Rating **3100/310 kg**

PLACE THESE INSTRUCTIONS IN THE VEHICLE'S GLOVEBOX AFTER INSTALLATION IS COMPLETED

WARNING:

1. Do not, drill, cut, weld or otherwise modify the tow bar.
2. If you are using electric welding on a motor vehicle, **always** check that the vehicle is not equipped with electronic engine or instrument management equipment. Failure to do so could **destroy** any onboard computers. If in doubt, check with the vehicle's manufacturer.
3. The high tensile fasteners supplied with this product were used to achieve the specified rating. If replacement is required ensure that fasteners of the same rating & quality are used. Contact an authorised **Trailboss** dealer if further information is required.
4. If TBM is used in inverted position tow ball may make contact with rear tailgate when lowered, which could cause damage.

General:

1. Ensure all hardware items have been included refer to assembly diagram.
2. It is recommended that the instructions are read through and completely understood before making any attempt to fit this product.
3. Be wary of any changes to vehicle designs or other accessories that may conflict with the installation of this product.
4. Before drilling ensure that the area is clear of fuel, electrical & other components.
5. All holes drilled into the body panels shall have all burrs & swarf removed then coated with a suitable rust preventative paint.
6. For vehicles that require the bumper to be cut. Ensure cut out area is in correct position on the vehicle prior to cutting the bumper.
7. The high tensile fasteners supplied with this product were used to achieve the specified rating. If replacement is required ensure that fasteners of the same rating & quality are used. Contact an authorized **Trailboss** dealer if further information is required.
8. Ensure that all hardware is fastened to torque list below check fasteners on regular basis.
9. Tow bar load rating sticker provided with this product shall be conspicuously located on inside rear end of the driver's door. **(See diagram below).**
10. Trailboss recommends that you check your tow ball to ensure that it complies with the Australian standards **AS 4177.2.**
11. **PLEASE NOTE:** It is advised to remove your lug or tbn when not actually towing so as to produce a clear view of the vehicles registration plate if obscured, and to also provide maximum available departure angle
12. Pull Pin must be fit in down position.

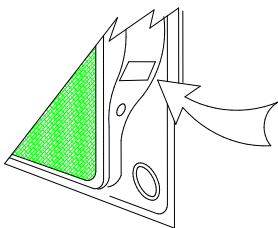

Place load rating sticker
inside driver's door here

FOR TRAILER TOWING PURPOSES ONLY
For towing capacity details please refer to vehicle owner's manual or to the manufacturer. Overloading can void your warranties.

RECOMMENDED ASSEMBLY TORQUE LISTING

<u>Diameter</u>	
M6	9.5 Nm
M8	21.7 Nm
M10	43.4 Nm
M12	125Nm
M14	146 Nm
M16	189.8 Nm

Tow bar Maintenance and Care.

Trailboss recommends that bolt torque's, as listed below, are routinely and regularly inspected and checked for correct tension. Replace any worn or defective parts.

We recommended to remove Tow Ball Mounts (TBM's, tongues or lugs) when not being used for any considerable length of time.

So as to avoid injury, when not towing it is suggested that the tongue, Pull Pin and R-clip are removed then stored in a safe, clean and dry place, away from excessive moisture.

Hitch Pull Pins and spring "R" clips are regularly checked for proper installation. Replace any worn or defective parts.

TRAILBOSS

Towbar Fitting Instructions
 To Suit **mitsubishi pajero sport QE series**
 Part Number **QTCL655L**
 Rating **3100/310 kg**

PLACE THESE INSTRUCTIONS IN THE VEHICLE'S GLOVEBOX AFTER INSTALLATION IS COMPLETED

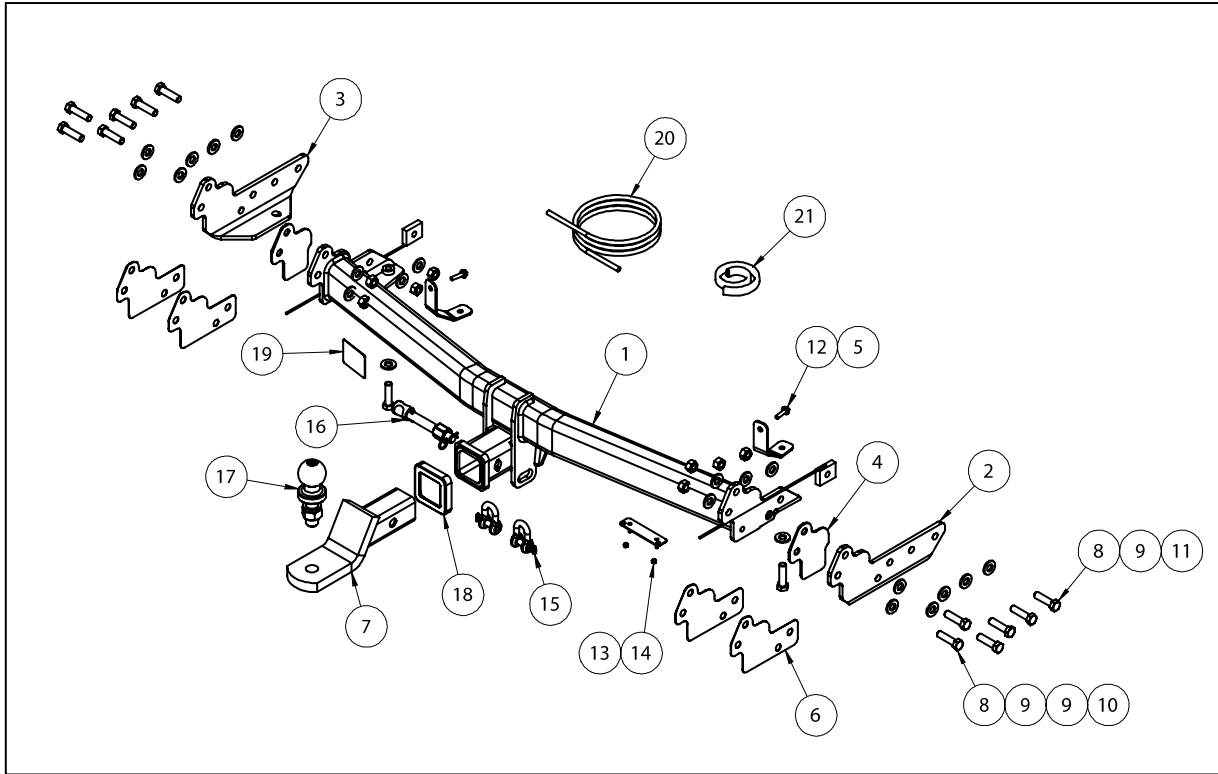

QTY.	DESCRIPTION	ITEM NO.
1	PAJAJERO SPORT WELDED ASSEMBLY	1
1	SIDE ARM BRACKET-RHS	2
1	SIDE ARM BRACKET-LHS	3
2	SPACER	4
2	BUMPER TAB BRACKET	5
4	SHIM PLATE	6
1	CLASS 4 TBM	7
14	SET SCREW M12x45x1.25P G10.9	8
22	WASHER FLAT 1/2"x1 1/8"x1/8"	9
8	HEX NUT M12x1.25 PC8	10
2	PLATE-300MM-WIRE M12x1.25-40x32MM	11
2	TEK SCREW 14-20 HEX HD 22mm	12
1	PLUG BRACKET	13
2	NUT NYLOC M4-0.7 Z/P	14
2	10mm "D" SHACKLE	15
1	SILENT HITCH PIN-SILVER	16
1	50MM TOWBALL	17
1	HITCH BOX COLLAR COVER	18
1	ACRYLIC COMPLIANCE PLATE	19
1	WIRING LOOM	20
1	BUMPER TRIM PINCH WELD 300MM	21

TRAILBOSS

Towbar Fitting Instructions
To Suit **mitsubishi pajero sport QE series**
Part Number **QTCL655L**
Rating **3100/310 kg**

PLACE THESE INSTRUCTIONS IN THE VEHICLE'S GLOVEBOX AFTER INSTALLATION IS COMPLETED

1. Remove 1x Screw from underside of vehicle, behind rear wheel arch.

Repeat for opposite side of vehicle.

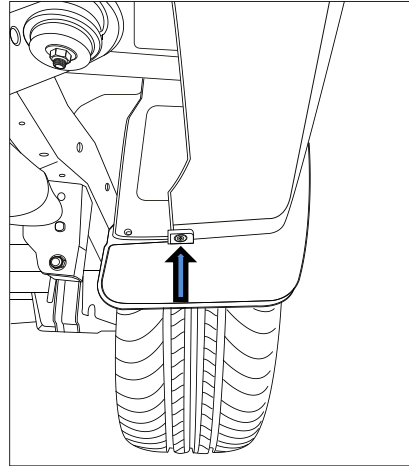

2. Remove 2x Screws and 2x push rivets securing mud guard to rear side of rear wheel arch; remove mud guard.

3. Remove 1x screw securing rear bumper to vehicle at rear wheel arch.

Repeat steps 2. and 3. for opposite side of vehicle.

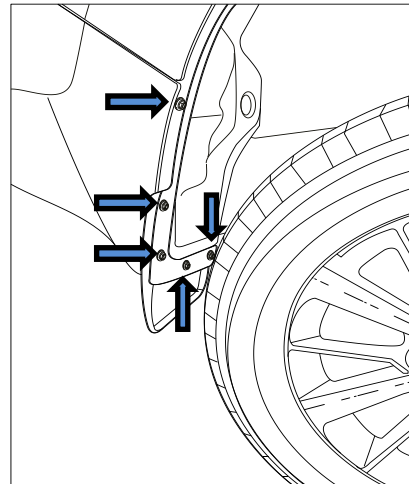

4. Remove 1x Screw securing lower tail light to rear bumper.

Repeat for opposite side of vehicle.

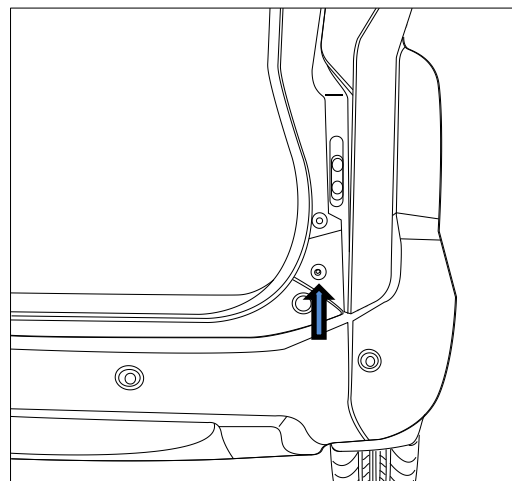

Towbar Fitting Instructions
To Suit **MITSUBISHI PAJERO SPORT QE SERIES**
Part Number **QTCL655L**
Rating **3100/310 kg**

PLACE THESE INSTRUCTIONS IN THE VEHICLE'S GLOVEBOX AFTER INSTALLATION IS COMPLETED

5. Remove and disconnect lower tail light.
6. Remove 1x Screw securing rear bumper to vehicle rear panel.

Repeat steps **5.** and **6.** for opposite side of vehicle.

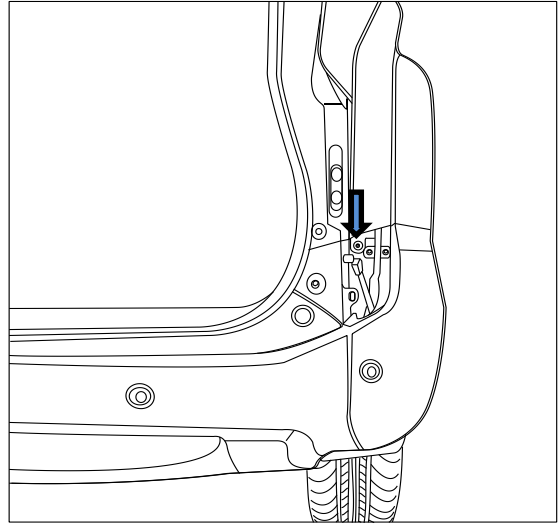

7. Remove 2x push rivets from underside of rear bumper.

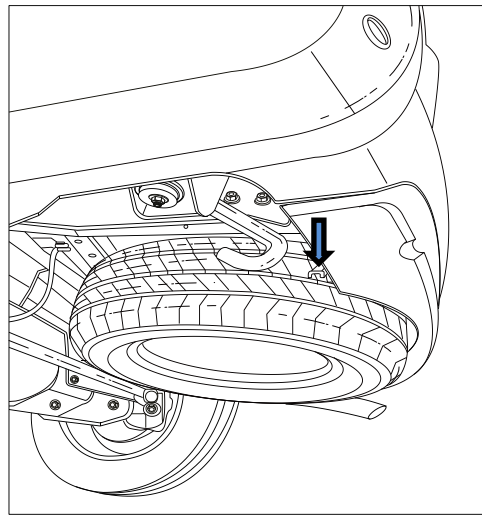

8. Carefully unclip and remove rear bumper. Disconnect parking sensor and lower tail light loom as required.
9. Lower spare wheel as per vehicle's Owner's Manual.
10. Remove and retain 3x Screws securing bumper tab bracket to rear panel of vehicle; remove and retain bumper tab bracket.

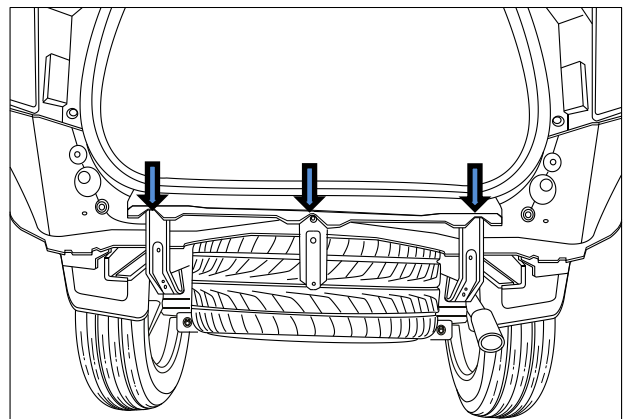

TRAILBOSS

Towbar Fitting Instructions
To Suit **mitsubishi pajero sport QE series**
Part Number **QTCL655L**
Rating **3100/310 kg**

PLACE THESE INSTRUCTIONS IN THE VEHICLE'S GLOVEBOX AFTER INSTALLATION IS COMPLETED

11. Remove and discard 4 Nuts securing factory tow hook from LHS of vehicle; remove and discard factory tow and bolt plate.

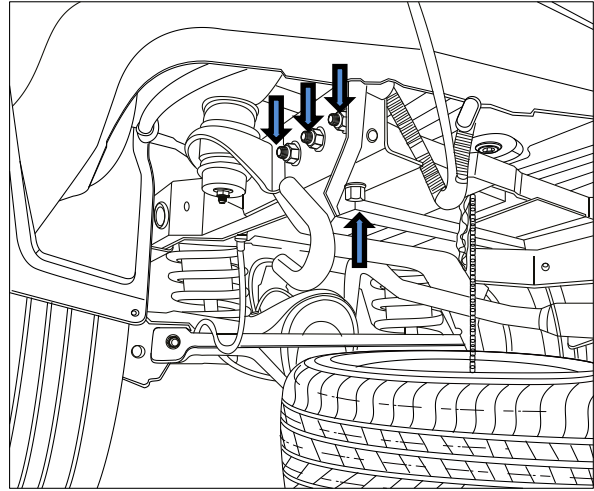

12. Remove and discard 3 Nuts securing shipping hook from RHS of vehicle; remove and discard shipping hook and bolt plate.

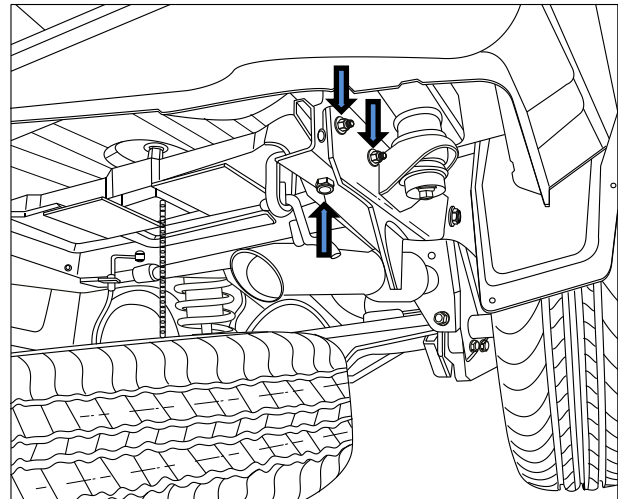

13. Install 2x bumper tab brackets onto bar using 1x Tek screw per bracket. Note orientation prior to fitment.

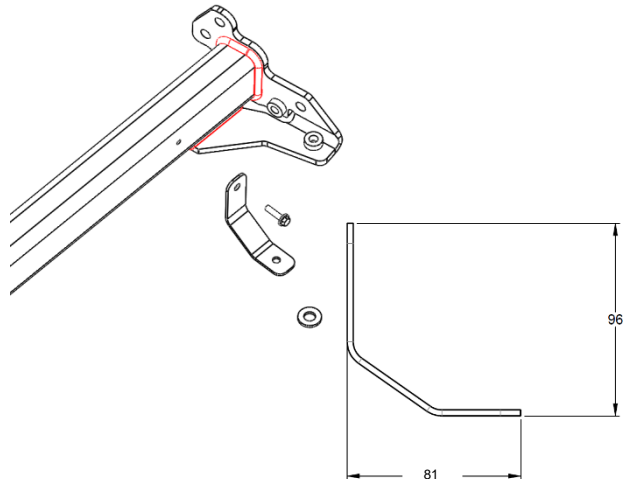

Towbar Fitting Instructions
To Suit **mitsubishi pajero sport QE series**
Part Number **QTCL655L**
Rating **3100/310 kg**

PLACE THESE INSTRUCTIONS IN THE VEHICLE'S GLOVEBOX AFTER INSTALLATION IS COMPLETED

14. Loosely fit sidearm bracket to chassis rail using 1x M12 Set Screw, complete with 1x Flat washer and 1x tapped plate on wire, in forward mounting hole.

Loosely secure sidearm bracket to chassis rail using 1x M12 Set screw, complete with 2x Flat washer and 1x M12 Nut, in 2nd forward mounting hole.

Repeat for opposite side of vehicle.

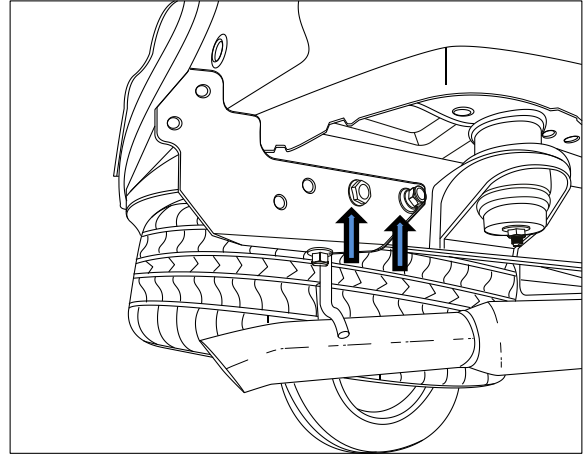

15. Loosely secure weld Nuts of towbar welded assembly to chassis rail and sidearm bracket using 2x M12 Set screws, complete with 1x flat washer per set screw.

Repeat for opposite side of vehicle.

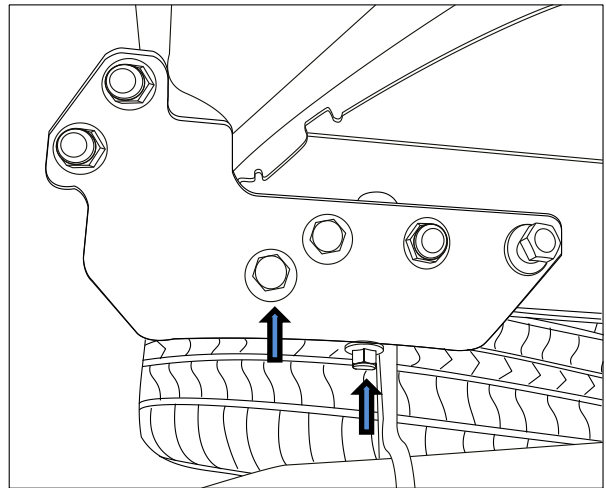

16. Insert spacer plate and any required shims, and loosely secure towbar welded assembly to side arm bracket using 3x M12 Set screws, complete with 2x Flat washers and 1x M12 Nut per set screw.

Repeat for opposite side of vehicle.

17. Tighten all set screws to torque listed on page 2 of this document.

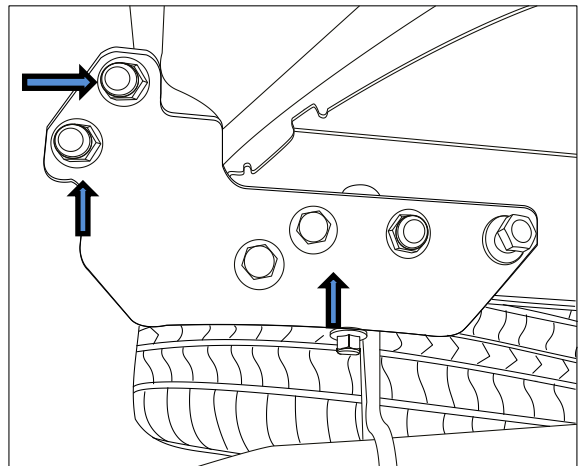

Towbar Fitting Instructions
To Suit **MITSUBISHI PAJERO SPORT QE SERIES**
Part Number **QTCL655L**
Rating **3100/310 kg**

PLACE THESE INSTRUCTIONS IN THE VEHICLE'S GLOVEBOX AFTER INSTALLATION IS COMPLETED

FOR STANDARD BUMPER

18. Identify centreline of rear bumper and make trapezoidal cutout 70mm tall x 90mm wide at upper edge and 140mm at lower edge, as measured following the outside contour of the bumper.

19. Fit pinch weld provided to edge of cut.

Bumper profile for illustration purposes only

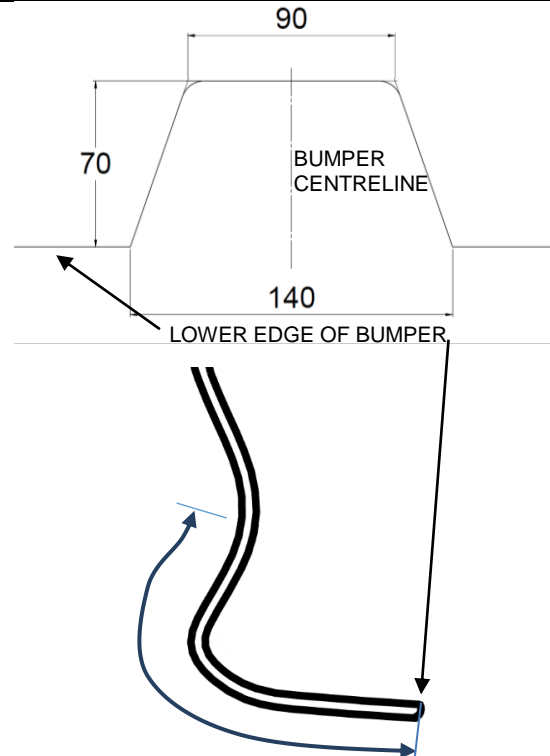

FOR OEM ACCESSORY "REAR UNDER COVER" PART NUMBER MZ330918

20. Identify centreline of rear bumper and make cutout 75mm tall x 100mm, as measured following the outside contour of the bumper.

21. Fit pinch weld provided to edge of cut.

Bumper profile for illustration purposes only

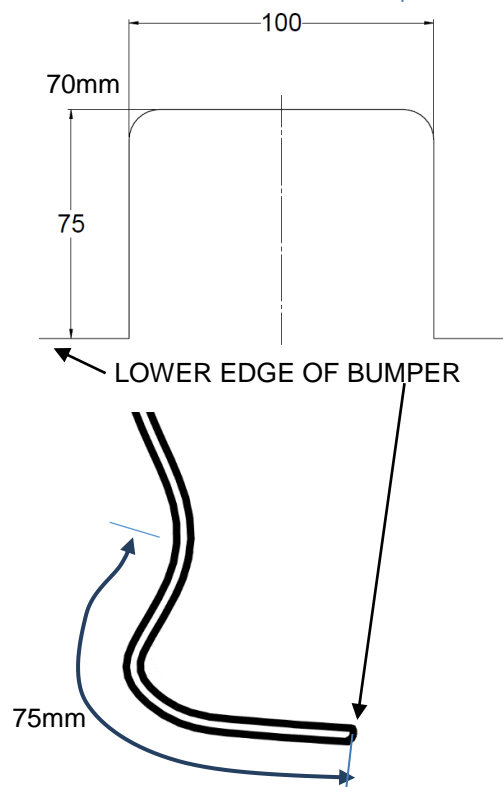

TRAILBOSS

Towbar Fitting Instructions
To Suit **MITSUBISHI PAJERO SPORT QE SERIES**
Part Number **QTCL655L**
Rating **3100/310 kg**

PLACE THESE INSTRUCTIONS IN THE VEHICLE'S GLOVEBOX AFTER INSTALLATION IS COMPLETED

22. Unclip inner trim from bumper and cut inner trim as shown by dotted line. Use reference holes as cutting guide.

Secure wiring to bumper using cable ties.

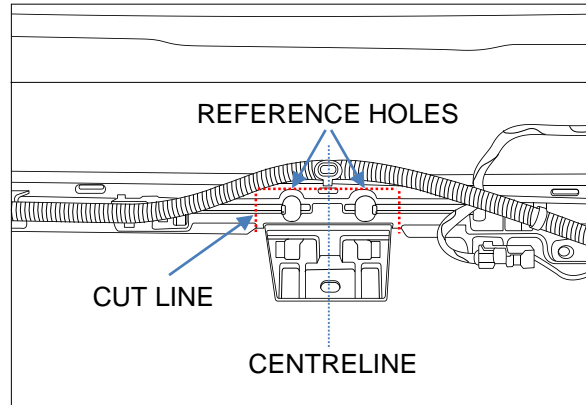

23. Mark out and drill 2x \varnothing 5mm holes 69mm apart on bumper skin to support plug bracket. Feed bracket threads through drilled holes prior to reinstalling bumper.

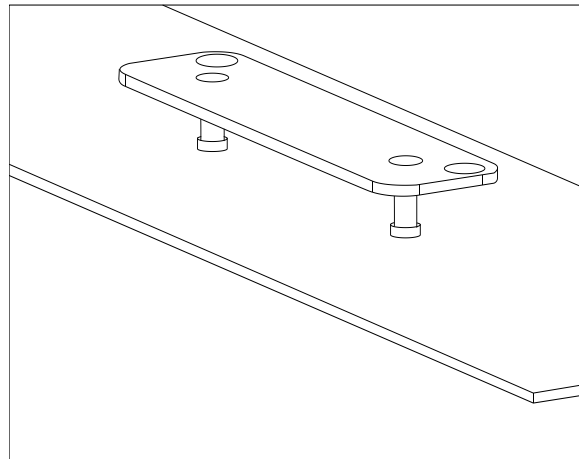

24. Cut bumper tab bracket 45mm below mounting holes, to provide clearance to towbar. Coat cut material with rust inhibitor.

25. Reinstall bumper tab bracket to rear panel of vehicle using retained screws.

26. Reinstall rear bumper following steps 1-9 in reverse order.

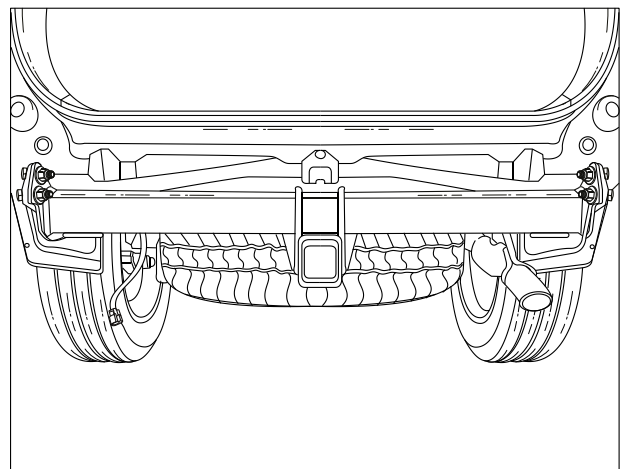



Wiring Loom Fitting Instructions
To Suit Mitsubishi Pajero Sport
Part Number 101249-WL (QTCL655L)

Wiring Loom Installation Instructions

Mitsubishi Pajero Sport
Part No: 101249-WL

Tail Harness Length Required: 1800mm
ECU Required: 04826

Wiring Loom Installation Time: Approx. 30 Mins

TRAILBOSS

Wiring Loom Fitting Instructions To Suit Mitsubishi Pajero Sport Part Number 101249-WL (QTCL655L)

1. In the luggage compartment, remove the LHS access panel and the tools inside.
2. Remove the LHS tail light assembly trim by removing the two screws.
3. Dislodge the tail light assembly by disengaging three clips. **Ensure to take extreme caution to avoid damaging clips or parts when removing the tail light assembly.**
4. Remove the LHS tail light assembly by disconnecting the tail light connector behind the grommet.
5. At the LHS rear quarter exterior of the vehicle, locate a suitable position on the vehicle sheet metal area and drill out a Ø30mm hole (1). File down and rough or sharp edges after drilling and apply rust inhibitor.



6. In the engine bay, locate the harness with the 4-way connector (1) near the battery. Connect the trailer patch engine harness 4-way connector (P/No: 101249-WL) (2) to the vehicle harness connector (1). **Do not connect the harness ring terminal to the battery terminal yet.**

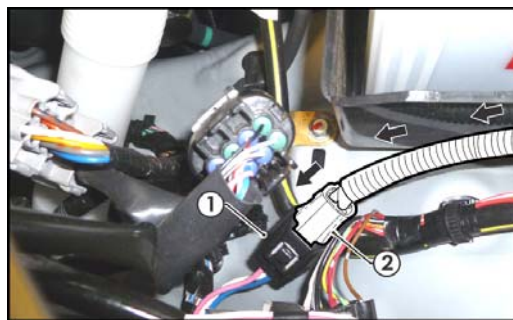

7. Inside the front passenger cabin area, remove the LHS front passenger kick trim by releasing the three fasteners.

Wiring Loom Fitting Instructions To Suit Mitsubishi Pajero Sport Part Number 101249-WL (QTCL655L)

8. Locate the vehicle kick panel harness 4-way and 2-way connectors and patch the kick panel harness patch (P/No: 101249-WL) in between.

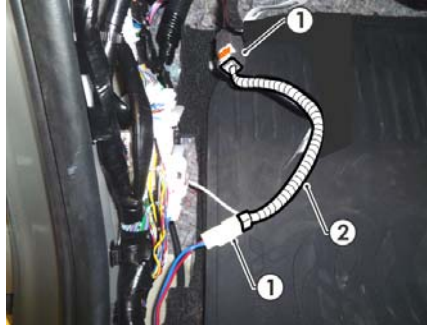

9. At the LHS rear quarter tool compartment cavity, locate the break-out connector (1) and connect the trailer patch (2) (P/No: 101249-WL) 10-way connector to the vehicle mating break-out connector (1).

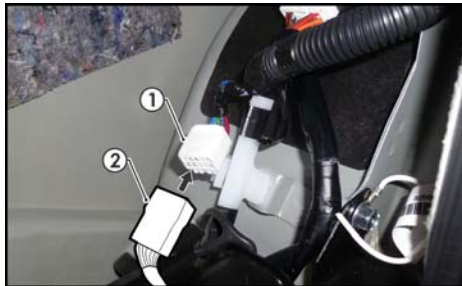

10. Connect the trailer patch ECU connector to the ECU. Secure the ECU onto the vehicle LHS wheel arch sheet metal area at a suitable location using double sided tape. **Ensure the ECU is mounted with the connector is facing downwards.**
11. Secure the trailer patch ground ring terminal to the vehicle grounding point using the existing fastener.
12. At the LHS rear exterior of the vehicle, dislodge the LHS vehicle tail light harness grommet.
13. Route a guide wire into the vehicle grommet hole, into the LHS rear quarter interior area and retrieve the trailer patch reverse wire terminal branch to the exterior. Remove the guide wire after routing.

Wiring Loom Fitting Instructions To Suit Mitsubishi Pajero Sport Part Number 101249-WL (QTCL655L)

14. On the LHS of the luggage compartment, following the table below, connect the ezy-tap (1) to the vehicle reverse wire (2), then connect the trailer patch terminal (3) to the ezy-tap (1).

Function	Trailer Patch	Vehicle Connector
REVERSE	BLACK/WHITE	RED / BLACK

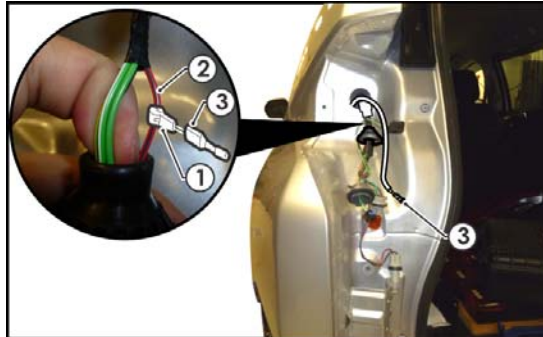

15. At the rear exterior of the vehicle, mount the tail harness socket to the towbar mounting bracket using M4 fasteners (not supplied).
16. Route the tail harness (tail length: 1800mm) across the LHS.
17. Connect the tail harness 8-way connector to the trailer patch 8-way mating connector.
18. In the engine bay, connect the power harness ring terminal to the battery positive terminal.
19. Refit the tail light.
20. Test the trailer wiring harness function using a light board or multi-meter.
21. Secure all harnesses using cable ties (not supplied).
22. Re-fit all removed parts and secure all fasteners, ensuring there are no squeaks or rattles.
23. Place the fitting instructions in the glove box after fitment.
24. The RPA system can be disabled via a switch on the dash.



FITTING INSTRUCTIONS

Silent Anti-Rattle Hitch Pin (PRO001)

• These fitting instructions are supplied to ensure understanding of how the HITCH PIN should be fitted and used correctly.

• Once installed, we recommend **ALL** instructions are kept and placed in the vehicle glove box.

NOTE: Routine maintenance and inspection of the towbar & HITCH PIN is required. Regularly inspect for wear and check the tightness of the Hitch Pin. Follow instructions below to retighten the nut when necessary.

***Do not tow with your vehicle if the R CLIP or the HITCH PIN is loose or missing. Replacement parts are available from your Pro Series Distributor.**

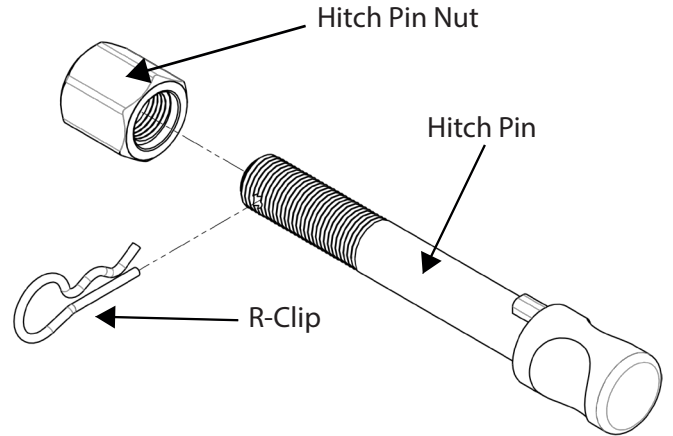

Fig 1. Silent Anti-Rattle Hitch Pin assembly

STEP 1

Insert Trailer Ball Mount (TBM) into towbar HITCHBOX, aligning hole in TBM SHANK with hole in HITCHBOX (Fig 2).

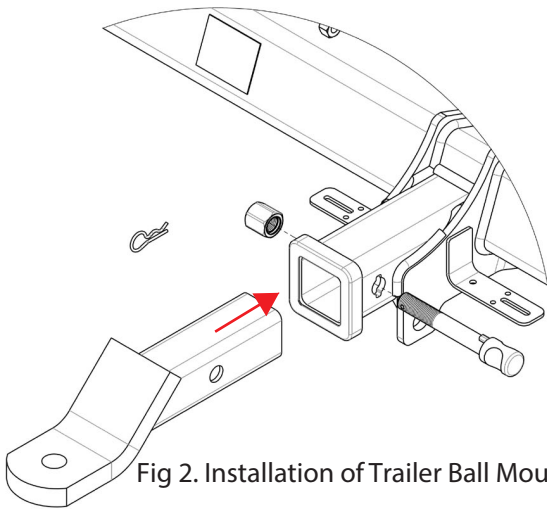

Fig 2. Installation of Trailer Ball Mount

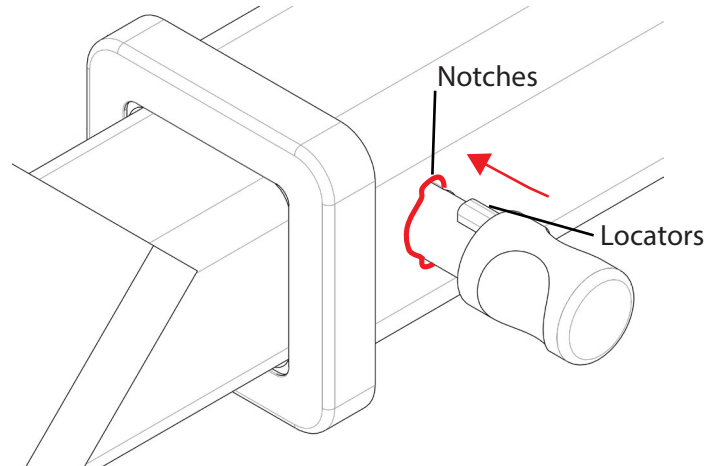

Fig 3. Silent Anti-Rattle Hitch Pin orientation

STEP 2

Insert HITCH PIN through hole in HITCHBOX and hole in TBM SHANK; ensure the LOCATORS are inserted into the NOTCHES in the HITCHBOX (Fig. 3).

STEP 3

Screw HITCH PIN NUT onto HITCH PIN ; tighten HITCH PIN NUT until finger tight, ensuring TBM is restrained from movement.

STEP 4

Tighten HITCH PIN NUT by turning nut a further 1/8th of a turn in the clockwise direction using a 24mm spanner (Fig. 4).

STEP 5

Install HITCH PIN R CLIP through the hole on the HITCH PIN (Fig. 1).

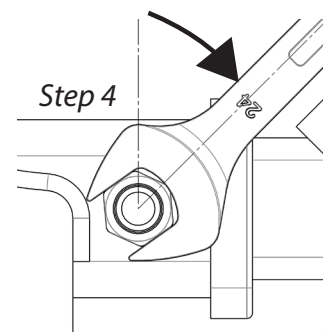

Fig 4. Tightening of Silent Anti-Rattle Hitch Pin Nut