



## TOWBAR INSTALLATION INSTRUCTIONS

PART NUMBER QTCL659L

MITSUBISHI OUTLANDER ZJ/ZK/ZL CL4

### PRODUCT DETAILS:

<b>Part Number:</b>	QTCL659L	<b>Maximum Towing Braked:</b>	2000	kg
<b>ECU Number:</b>	04826	<b>Maximum Towing Unbraked:</b>	750	kg
<b>Tail Harness Length Required:</b>	1200 mm.	<b>Maximum Static Ball Load:</b>	200	kg
<b>TBM/Lug Part Number:</b>	21347			

### FITTING DETAILS:

<b>Towbar Installation Time:</b>	60 Mins.	<b>RPA Disable/Other:</b>	YES
<b>Total Installation Time:</b>	80 Mins.		
<b>Bumper Cut Required:</b>	Yes		

#### Note:

- Electric brake Input near blue connector
- RPA disable via switch on the dash.

### TRAILBOSS RECOMMENDS THAT INSTRUCTIONS ARE READ AND UNDERSTOOD COMPLETELY PRIOR TO FITMENT.

#### BEFORE YOU START:

Check all hardware items have been included refer to assembly diagram.  
Please ensure this towbar is only fitted to vehicle models as per Trailboss application guide.

#### Bumper Cuts

Vehicle and bumper variations can and do occur during vehicle manufacture after initial towbar design. Fitment of towbar to vehicle and accuracy of bumper cut must be assessed prior to any bumper modifications made. Incorrect bumper cuts are not covered under Trailboss warranty.

**NOTE: Bumper cuts need to be approached with care, refer to notes below.**

**Bumper centreline** – where the centreline of the bumper needs to be determined, the installer must assess centre point by measurement of bumper width or determining two symmetrical reference points to give centreline.

**Bumper edge** – To assist with accurate bumper cut measurement, reference to the start of the bumper edge is now being commonly used.

- o Measure from bottom edge along bumper and around corner to the 70 mm point (Figure 1).
- o Do not measure from visible bumper front of corner, upwards (Figure 2).

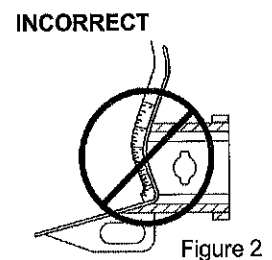
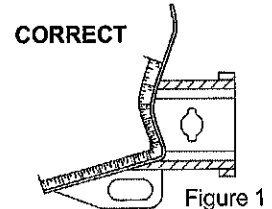

#### Drilling

- For any required drilling during installation, ensure that the area is clear of fuel, electrical & other components that may be damaged.
- All holes drilled into metal body panels shall have all burrs & swarf removed then coated with a suitable rust preventative paint.

#### Bolts/Fasteners

- Ensure that all hardware is fastened to correct torque as specified in this fitting instruction.
- All fasteners supplied with this product are used to achieve a specified clamp loading. If replacement is required ensure that fasteners of the same grade and class are used.

**NOTE: Achieving correct torque is critical to proper installation and responsibility of the installer. Towbar failures attributed to tension issues from over tightening or under tightening are not covered by Trailboss warranty.**

#### Product Labels

- a. Towbar load rating sticker provided with this product shall be conspicuously located on inside rear end of the driver's door.

#### WARNING:

**Do not, drill, cut, weld or otherwise modify the towbar.**

**FOR TOWING PURPOSES ONLY - This towbar is designed and tested by Trailboss to adhere to ADR 62/02 which provides only for the expected load demands of towing.**

### TOWBAR ASSEMBLY DIAGRAM

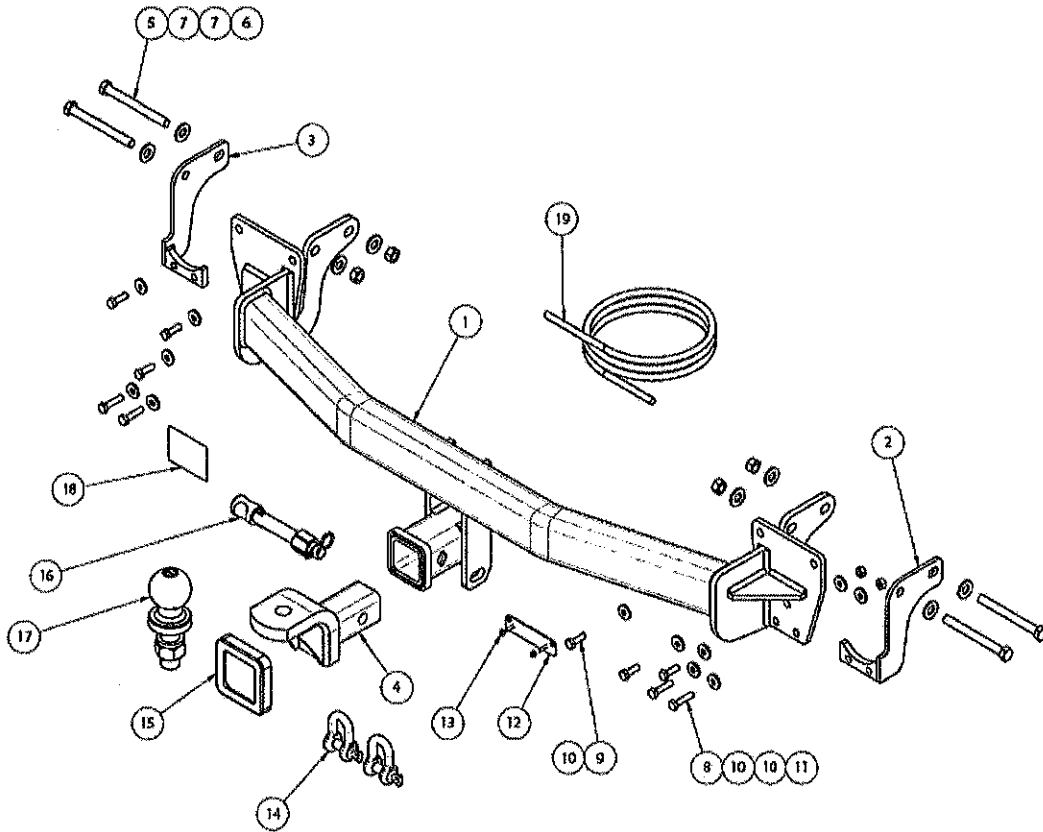

ITEM	DESCRIPTION	QTY
1	OUTLANDER WELDED ASSY	1
2	PLATE ASSY RH	1
3	PLATE ASSY LH	1
4	TRAILER BALL MOUNT	1
5	BOLT HEX HD M12x120x1.25P	4
6	NUT HEX HD M12x1.25P	4
7	WASHER PLAIN 1/2x1-1/8x16G	8
8	BOLT HEX HD M8x35x1.25P	4
9	SET SCREW HEX HD M8x25x1.25P	6
10	WASHER PLAIN M8x22x3	14

ITEM	DESCRIPTION	QTY
11	NUT HEX M8x1.25P	4
12	PLUG BRACKET	1
13	NUT NYLON LOCK HEX M4x0.7P	2
14	"D" SHACKLE 10mm	2
15	HITCH BOX COLLAR COVER	1
16	SILENT HITCH PIN	1
17	TOWBALL 50mm	1
18	ACRYLIC COMPLIANCE LABEL	1
19	WIRING LOOM	1

1. Open tailgate and remove 4 x bumper mounting bolts.

Remove the tailgate rubber stops secured with 2 x bolts per stopper.

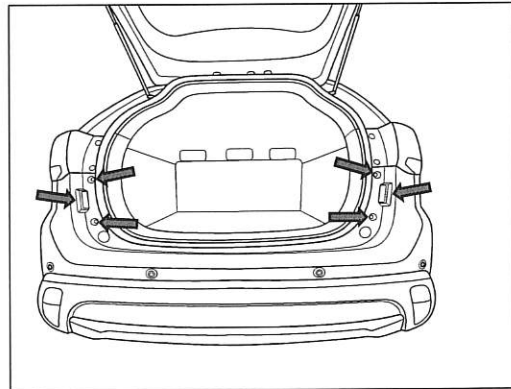

2. In wheel arch, remove 1 x hex bolt.

Repeat for other side.

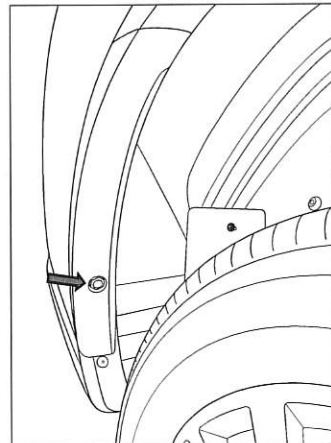

3. Remove bumper skirting (held with 3 x clips) to reveal 3 x scrivenets in the wheel arch.

Remove 3 x scrivenets.  
Repeat for other side.

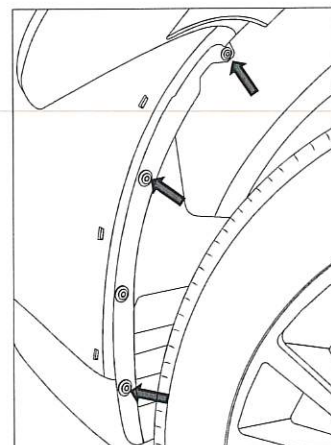

- 
4. Along the bottom of the bumper, remove 4 x screws.

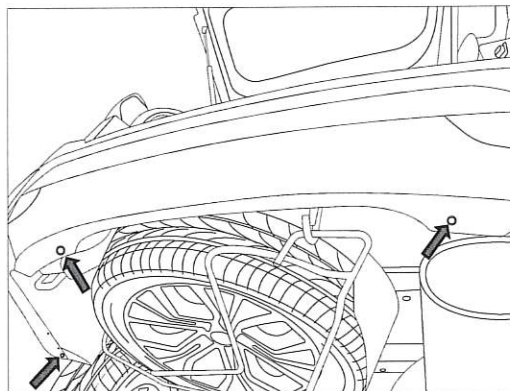

- 
5. Peel the bumper away from the edges and remove from vehicle.

Ensure to disconnect wiring connectors located on the LH side.

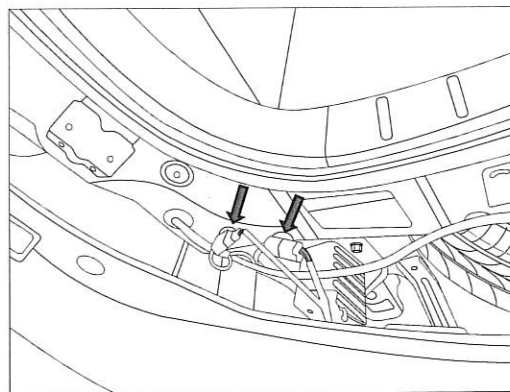

- 
6. Remove and discard the impact bracket secured with 3 x bolts.

Repeat for other side

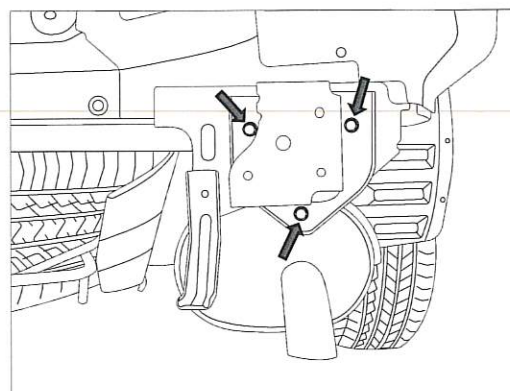

- 
7. Remove and discard the shipping hook secured with 3 x bolts.

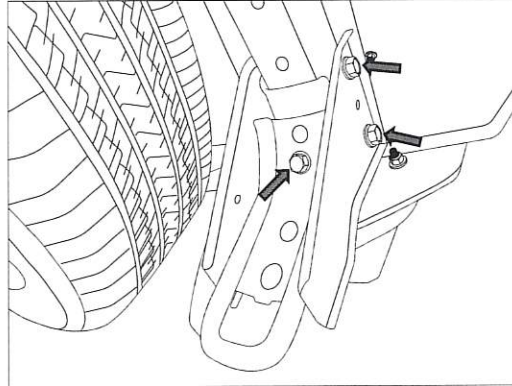

- 
8. For clearance, drop the exhaust from the 2 x rubber hangers.

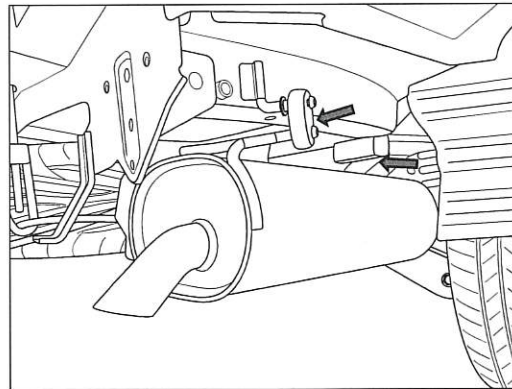

- 
9. Lift the crosstube assembly to the vehicle and loosely secure to the rear panel of the vehicle with 6 x M8 x25 bolts (3 per side) complete with 1 x washer per bolt.

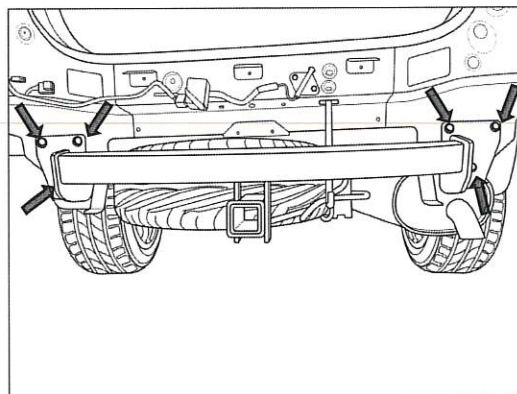



10. Position the RH Plate assembly to the outside of the RH chassis rail and loosely secure, along with the side of the crosstube assembly with 2 x M12 bolts complete with 2 x washers and 1 x nut per bolt.
11. Loosely secure the RH plate assembly to the crosstube assembly with 2 x M8 x 35 bolts complete with 2 x washers and 1 x nut per bolt.

Repeat for the LH side.

12. Position the towbar assembly and tighten all bolts to the following torques.

**M8 GR8.8 : 22Nm**

**M12 GR8.8 : 89Nm**

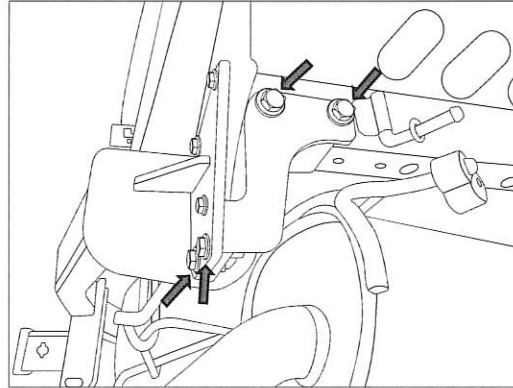

13. For the bumper cut.

Identify the centre line of the bumper. Measure 100mm up from the bottom edge of the bumper and 100mm wide (50mm either side of the bumper centreline). Cut this outline.

Remove all sharp edges or burrs from bumper after cut.

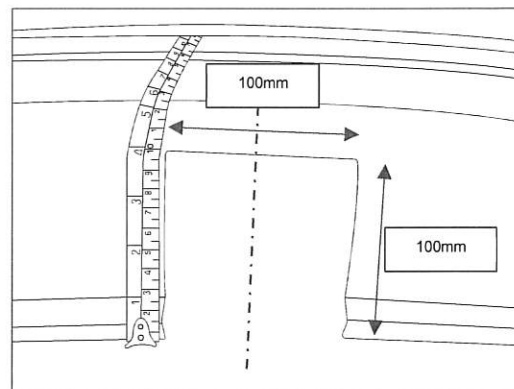

14. For the plug bracket.

Find an appropriate position on the bumper, Mark out and drill 2 x  $\varnothing$ 5mm holes 69mm apart on bumper skin to support plug bracket.

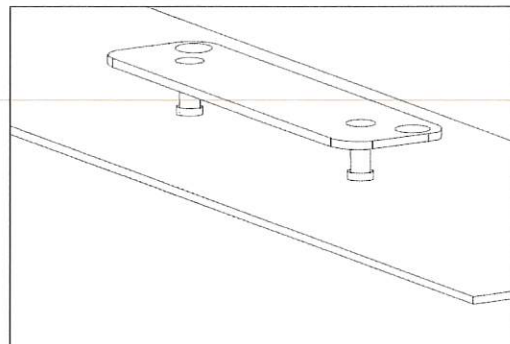

### IMPORTANT

Due to possible vehicle variations, always confirm any noted vehicle colour wires with a multi-meter to ensure the correct function is identified before soldering or scotch locking. For vehicle wires denoted with two colours (example; RED/GREEN) the first colour will always be the main wire colour while the second colour is the thinner trace colour on the wire.

15. Remove the LHS air vent.

**Note: If vehicle fitted with Blind spot remove the sensor by removing the 3 fasteners and disconnecting the connector prior to removing the vent.**

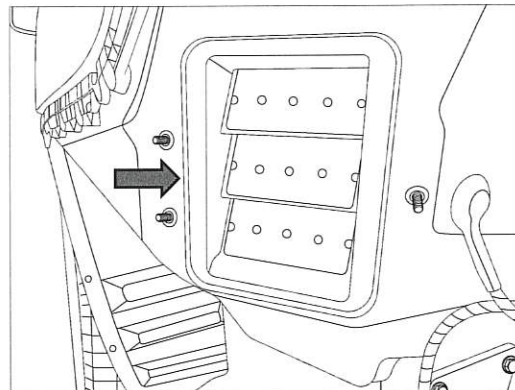

16. Drill a 30mm hole using a step drill in the area indicated. Remove any sharp edges and spray with rust inhibitor.  
**Note: Remove the foam pad prior to drilling.**
17. Route the trailer tail 1200mm across the towbar to the previously drilled hole allow enough length for the trailer socket to mount on the final step.
18. Slide the grommet to desired location and secure with supplied cable tie, ensure the grommet is seated properly.

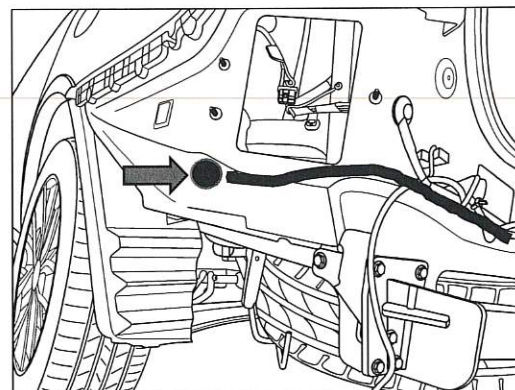



19. Plug the trailer ECU 04826 into the trailer patch (100893-WL) 12-way female connector.
20. Clean an area of the sheet metal inside the vehicle using supplied alcohol wipe place the ECU in this location ensuring good adhesion.  
**Note: Ensure the ECU connector is facing downwards.**
21. Reach in the vehicle and locate the 10- way trailer pre wire connector and connect the trailer patch.

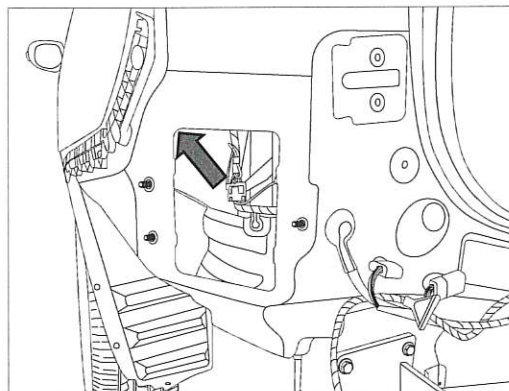

22. Secure the GND ring terminal to vehicle sheet metal using a tek screw (not supplied).
23. Locate the trailer patch harness blue 8-way female connector and mate to the trailer tail 8-way male connector.

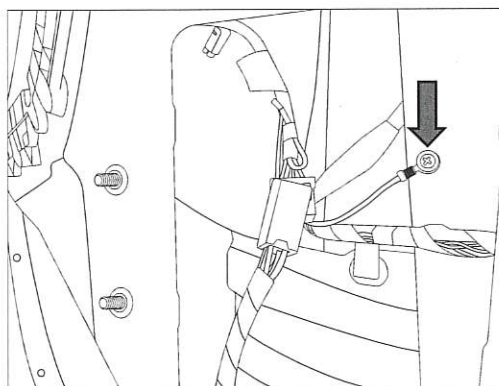

**This step is for PHEV only. For other models go to step 28.**

24. Locate the trailer patch 1-way connector orange wire and remove the blanking plug.
25. In the trailer patch kit retrieve the long power lead and mate with the 1-way to the trailer patch orange lead.

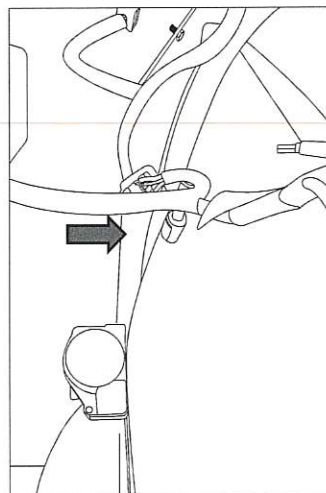

26. Remove the trims in the boot to access the rear battery.
27. Route the power harness ring terminal towards to battery and secure to the positive battery terminal post.

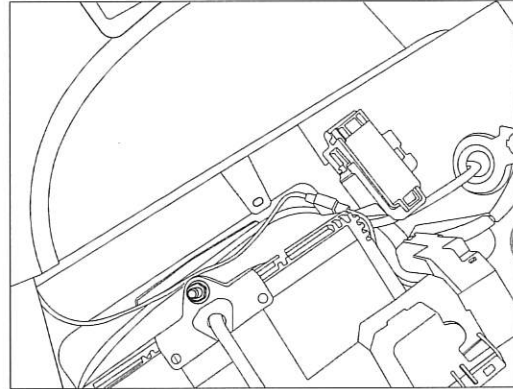

**This step is for non-PHEV only go to step 24.**

28. In the engine bay dislodge the fuse relay holder and move it to the side (this will allow easier access to the power prewire connector).

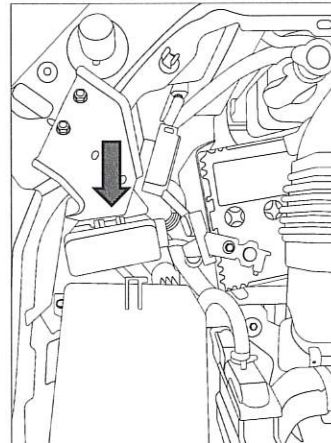

29. Locate and untape the 4 – way power prewire connector and remove the blanking plug.

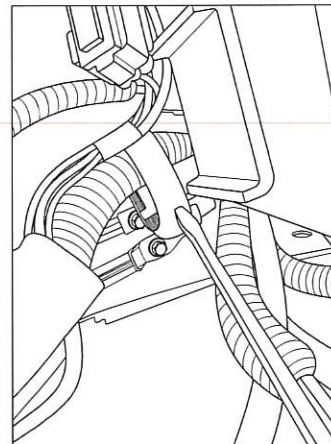

- 
30. Plug in the 4-way power prewire connector and route the ring terminal towards the battery and secure the ring terminal to the positive battery terminal post.

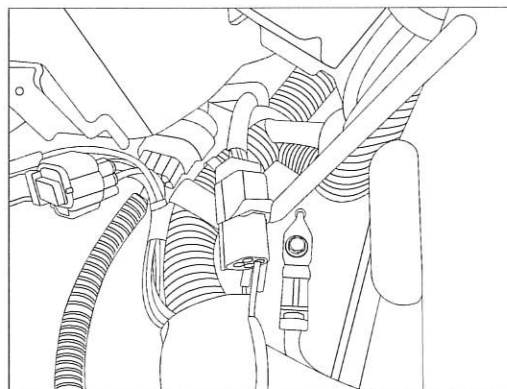

- 
31. Secure all harnesses using cables ties.  
32. Refit all removed parts and secure all fasteners, ensuring no squeaks or rattles.  
33. Test the trailer wiring harness function using a light board or multi meter.  
34. Place fitting instructions in the glovebox after fitment.
-





## CUSTOMER INFORMATION

PLACE THESE INSTRUCTIONS IN THE  
VEHICLE'S GLOVEBOX AFTER INSTALLATION

**THANK YOU FOR PURCHASING TRAILBOSS. WITH CORRECT MAINTENANCE AND CARE THIS PRODUCT WILL PROVIDE A LIFETIME OF TROUBLE-FREE OPERATION.**

### **TOWBAR MAINTENANCE AND CARE:**

1. Trailboss recommend that the towbar LUG or TBM (Trailer Ball Mount) Pull Pin and R-clip are removed and stored when not in use. Removal of LUG or TBM (Trailer Ball Mount) is advisable when not in use to assist with any of the following.
  - Ensure rear number plate is not obscured.
  - Allow maximum available departure angle and prevent any potential interference.
  - Prevent possible interference with vehicles reverse sensors or camera detecting a tow ball mount as an obstruction during reversing.
  - Removes towball mount as an obstruction for when moving around the rear of the vehicle.
2. Trailboss recommends routine inspection of your towbar to ensure trouble free towing.
  - Bolt security and tension should be regularly inspected and checked for correct tension. Replace any worn or defective parts with suitable grade & class fasteners. Inspection should be requested to coincide with vehicle major services.
3. It is the owner's responsibility to ensure towing and down ball weight capacities of the towing vehicle are not exceeded.
  - Towing and down ball weights allowable may differ according to model variations. Please refer to owner's manual or vehicle dealer to confirm exact rating for your vehicle model variant.
  - It is not uncommon for the vehicle tow rating to differ from the towbar rating. When this occurs, the lesser rating must be adhered to.
  - For vehicles fitted with enhanced vehicle functions that may be altered/changed when towing i.e Trailer sway mitigation, blind spot detection, adaptive cruise control etc. Please consult owner's manual to understand changes enabled when towing and after towing.

### **WARRANTY INFORMATION:**

Trailboss Towbars are covered by a Lifetime Warranty.

Our goods come with guarantees that cannot be excluded under the Australian Consumer Law. You are entitled to a replacement or refund for a major failure and for compensation for any other reasonably foreseeable loss or damage. You are also entitled to have the goods repaired or replaced if the goods fail to be of acceptable quality and the failure does not amount to a major failure.

For further details please contact customer service on 1800 812 017.

## PRO SERIES SILENT ANTI-RATTLE HITCH PIN

Your Trailboss towbar is equipped with a Pro Series Silent Anti-Rattle Hitch Pin technology to help reduce towbar tongue rattle in most driving conditions. Please ensure below instructions are understood and routine maintenance is carried out to ensure best towing experience.

Regularly inspect for wear and check the tightness of the Silent Anti-Rattle Hitch Pin. Follow instructions below to re-tighten the nut as necessary when movement and noise in the tow ball mount is noted.

- Before towing, ensure R-Clip is properly installed and hitch pin nut is installed and tensioned. Replacement parts are available from your Pro Series Distributor.

## TOWBALL MOUNT REMOVAL/INSTALLATION

### STEP 1

Insert Trailer Ball Mount (TBM) (a) into towbar hitchbox (b), aligning hole in TBM shank (c) with hole in hitchbox (d) (Fig. 1)

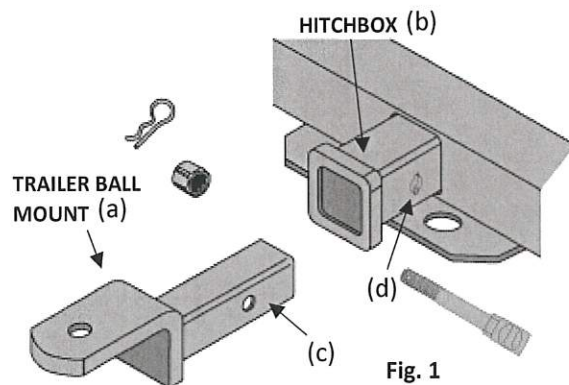

### STEP 2

Insert Silent Anti-Rattle Hitch Pin (e) through hole in hitchbox and hole in TBM shank (g); ensure the locators are inserted into the notches in the hitchbox (Fig. 2)

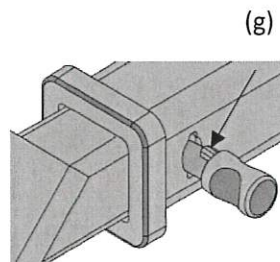

### STEP 3

Screw Silent Anti-Rattle Hitch Pin Nut (f) onto Smart Pin (g); tighten Smart Pin Nut until finger tight, ensuring TBM is restrained from up and down movement.

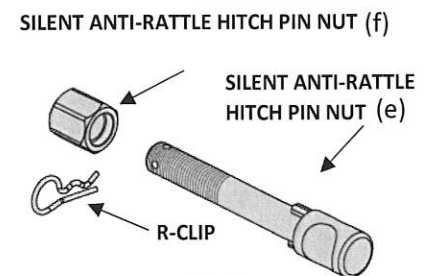

### STEP 4

Tighten Silent Anti-Rattle Hitch Pin Nut by turning nut a further 1/8th of a turn in the clockwise direction using a 24mm spanner (Fig. 4).

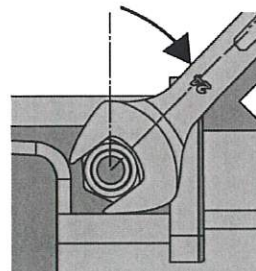

### STEP 5

Install Silent Anti-Rattle Hitch Pin R-Clip through the hole that provides best clearance or easiest access. (Fig. 5)

