



TOWBAR INSTALLATION INSTRUCTIONS

PART NUMBER QTCL661L

MITSUBISHI OUTLANDER 2M CL4

PRODUCT DETAILS:

Part Number:	QTCL661L	Maximum Towing Braked:	1600	kg
ECU Number:	04826	Maximum Towing Unbraked:	750	kg
Tail Harness Length Required:	1200 mm	Maximum Static Ball Load:	160	kg
TBM/Lug Part Number:	21232			

FITTING DETAILS:

Towbar Installation Time:	60 Mins.	RPA Disable/Other:	YES
Total Installation Time:	105 Mins.		
Bumper Cut Required:	Yes		

Note:

- Use Tail 04943 for RPA Disable.

TRAILBOSS RECOMMENDS THAT INSTRUCTIONS ARE READ AND UNDERSTOOD COMPLETELY PRIOR TO FITMENT.

BEFORE YOU START:

Check all hardware items have been included refer to assembly diagram.
Please ensure this towbar is only fitted to vehicle models as per Trailboss application guide.

Bumper Cuts

Vehicle and bumper variations can and do occur during vehicle manufacture after initial towbar design. Fitment of towbar to vehicle and accuracy of bumper cut must be assessed prior to any bumper modifications made. Incorrect bumper cuts are not covered under Trailboss warranty.

NOTE: Bumper cuts need to be approached with care, refer to notes below.

- Bumper centreline – where the centreline of the bumper needs to be determined, the installer must assess centre point by measurement of bumper width or determining two symmetrical reference points to give centreline.
- Bumper edge – To assist with accurate bumper cut measurement, reference to the start of the bumper edge is now being commonly used.
 - Measure from bottom edge along bumper and around corner to the 70 mm point (Figure 1).
 - Do not measure from visible bumper front of corner, upwards (Figure 2).

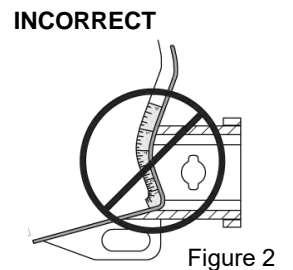
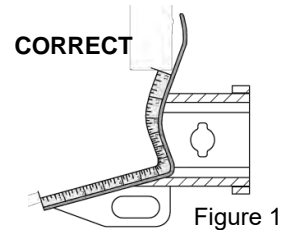

Drilling

- For any required drilling during installation, ensure that the area is clear of fuel, electrical & other components that may be damaged.
- All holes drilled into metal body panels shall have all burrs & swarf removed then coated with a suitable rust preventative paint.

Bolts/Fasteners

- Ensure that all hardware is fastened to correct torque as specified in this fitting instruction.
- All fasteners supplied with this product are used to achieve a specified clamp loading. If replacement is required ensure that fasteners of the same grade and class are used.

NOTE: Achieving correct torque is critical to proper installation and responsibility of the installer. Towbar failures attributed to tension issues from over tightening or under tightening are not covered by Trailboss warranty.

Product Labels

- a. Towbar load rating sticker provided with this product shall be conspicuously located on inside rear end of the driver's door.

WARNING:

Do not, drill, cut, weld or otherwise modify the towbar.

FOR TOWING PURPOSES ONLY - This towbar is designed and tested by Trailboss to adhere to ADR 62/02 which provides only for the expected load demands of towing.

i TOWBAR ASSEMBLY DIAGRAM

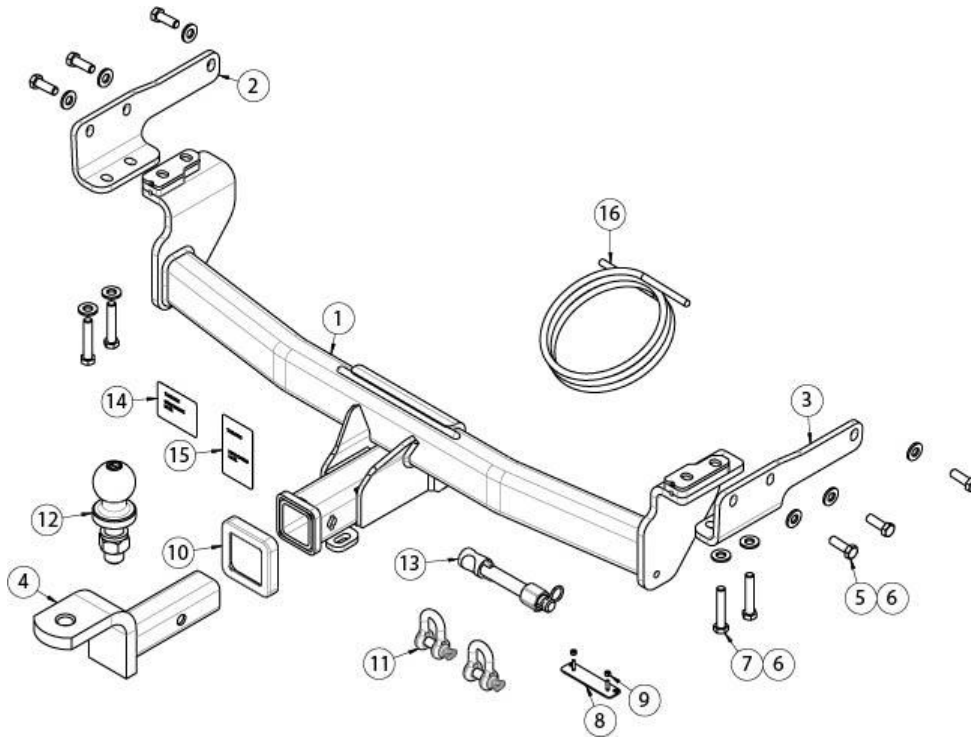

ITEM	DESCRIPTION	QTY
1	OUTLANDER GM/GN WELDED ASSEMBLY	1
2	SIDE ARM, LH	1
3	SIDE ARM, RH	1
4	TRAILER BALL MOUNT	1
5	SET SCREW HEX HD M12x35x1.25P	6
6	WASHER PLAIN 1/2"	10
7	BOLT HEX HD M12x65x1.25P	4
8	PLUG BRACKET	1
9	NUT NYLOC HEX HD M4x0.7P	2
10	HITCH BOX COLLAR COVER	1
11	"D" SHACKLE 10mm	2
12	TOWBALL 50mm	1
13	SMART PIN SILVER	1
14	COMPLIANCE LABEL	1
15	LOAD RATING LABEL	1
16	WIRING LOOM	1

1. Open tailgate and remove the 2 x screws securing each taillight. Pull rearwards to remove the taillight and ensure to disconnect the wiring harness.

Repeat for other side.

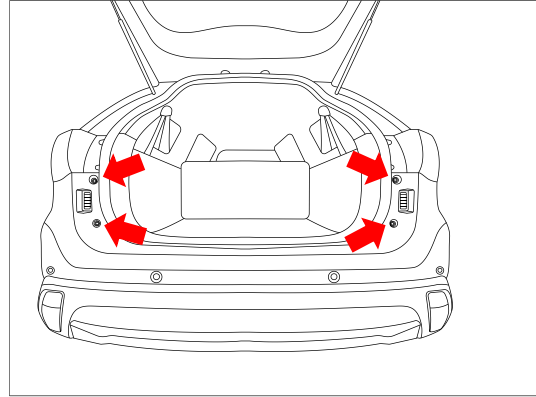

2. In the taillight cavity, remove the exposed 1 x screw. Remove the additional 1 x screw from the bumper.

Repeat for other side.

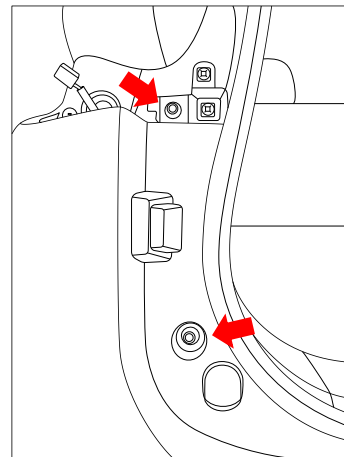

3. Remove the wheel skirting secured with the skirting moulding clips to allow for the removal of the bumper.

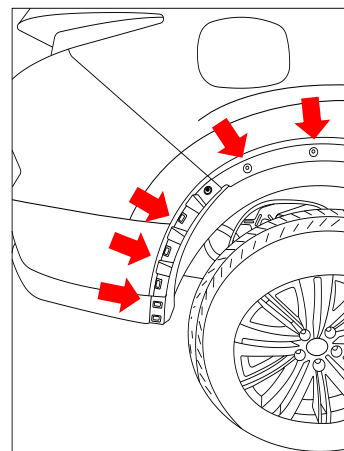

-
4. Remove 1 x screw from the bumper.

Repeat for the other side

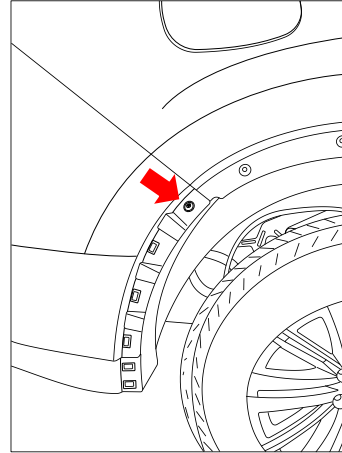

-
5. In wheel arch, remove 1 x scrivet.

Repeat for other side.

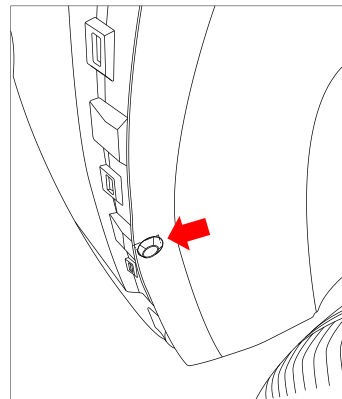

-
6. From under vehicle, remove 2 x scrivets from the wheel arch liner.

Repeat for other side.

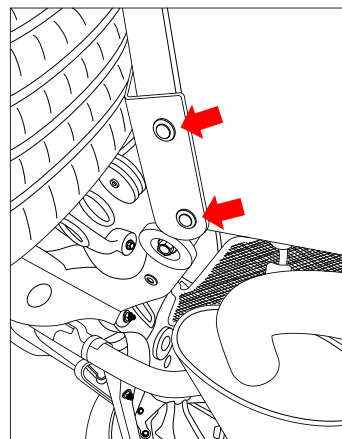

-
7. Peel away the wheel arch liner and remove 1x scrivet from the exposed plastic housing.

Repeat for other side.

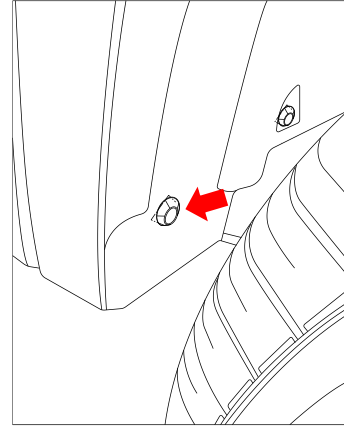

-
8. Remove 2 x scrivets from the underside of the bumper.

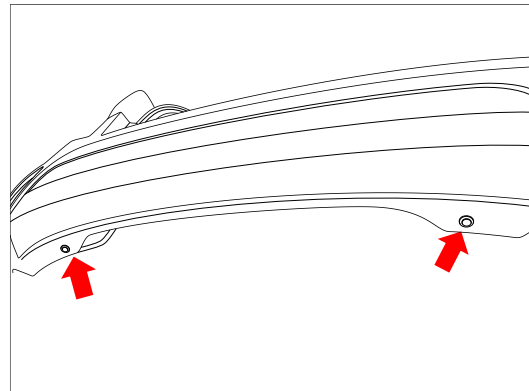

-
9. Peel bumper away from the sides and remove from vehicle, ensuring to disconnect the wiring harness located on the RH side.

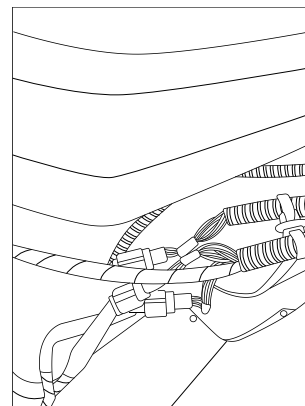

10. Position the LH side arm up to the chassis and loosely secure to the side with 3x M12x35 bolts complete with 1 x washer per bolt.

Repeat for other side.

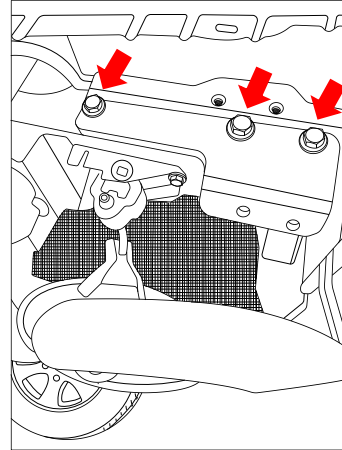

11. Lift the crosstube assembly up to the side arms and position it between the loosely fitted side arms and the chassis. Loosely secure each side from the bottom with 2 x M12x65 bolts complete with 1x washer per bolt.

12. Tighten all fasteners to the following torque:
M12 (Gr10.9) : 125Nm

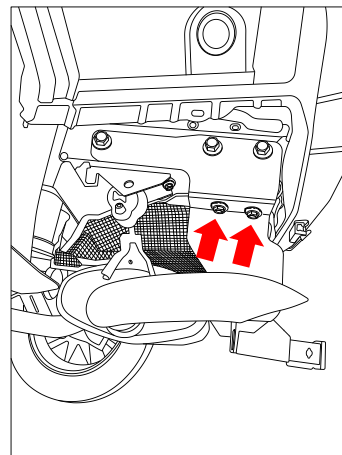

13. For the bumper cut.
Identify the centre line of the bumper.
Measure, mark off and cut a clearance section 50mm up from the bottom edge of the bumper and 90mm wide (45mm either side of the bumper centreline).

NOTE: Ensure you do not cut through any wiring or sensors (footswipe sensors) located on the inside of the bumper.

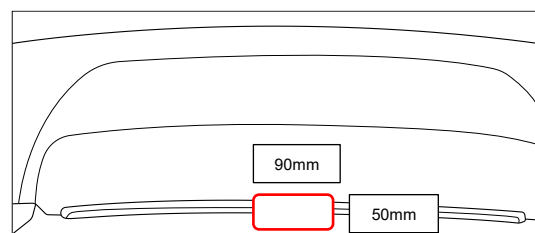

14. Remove all sharp edges or burrs from bumper after cut.

-
15. On the tailpipe cover in the bumper, mark off and remove the section as depicted.

Repeat for the other side.

NOTE: Ensure you do not cut through any wiring or sensors (footswipe sensors) located on the inside of the bumper.

16. Remove all sharp edges or burrs from the cover after cut.

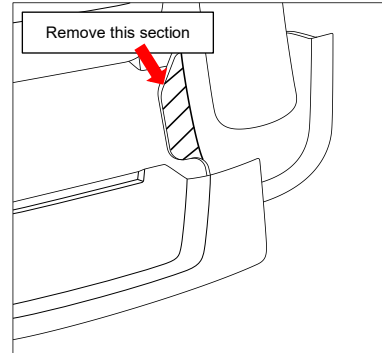

-
17. For the plug bracket.
Find an appropriate position on the bumper,
Mark out and drill 2 x \varnothing 5mm holes 69mm apart
on bumper skin to support plug bracket.

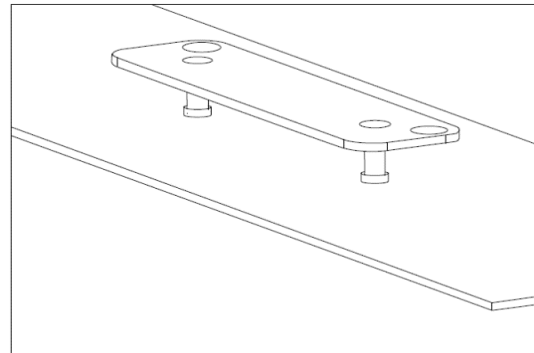

IMPORTANT

Due to possible vehicle variations, always confirm any noted vehicle colour wires with a multi-meter to ensure the correct function is identified before soldering or scotch locking. For vehicle wires denoted with two colours (example; RED/GREEN) the first colour will always be the main wire colour while the second colour is the thinner trace colour on the wire.

18. In the luggage compartment, remove the floor carpet (1).

19. Fold down the rear seats (2).

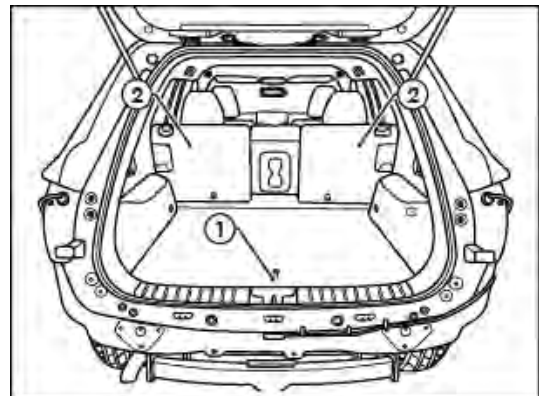

20. Remove the 2 trim clips (1) securing the rear scuff trim (2).

21. Remove the rear scuff trim (2).

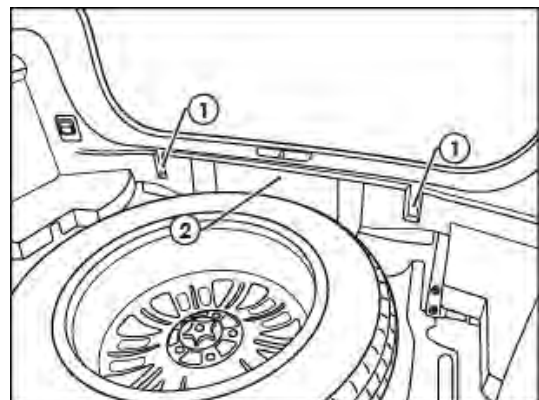

-
22. Dislodge the weather seal (1) around the LHS rear door
23. Remove the LHS rear door sill trim (2).

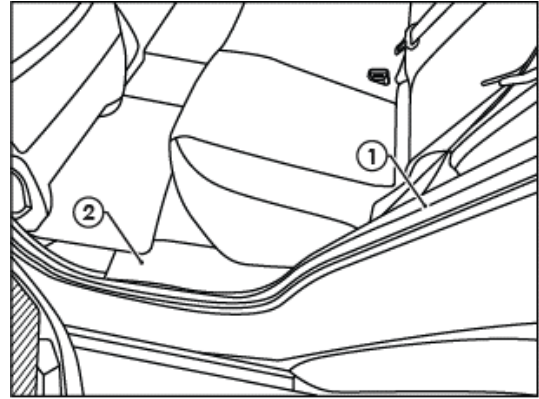

-
24. On the LHS Rear of the vehicle, remove bolts securing the LHS Rear Luggage compartment trim (1).
25. Locate the screw cover (2) behind the Side Release Lever (3). Remove the screw cover (2) and the screw.
26. Dislodge the left rear luggage compartment trim (1) and disconnect any harness connectors from behind the trim.

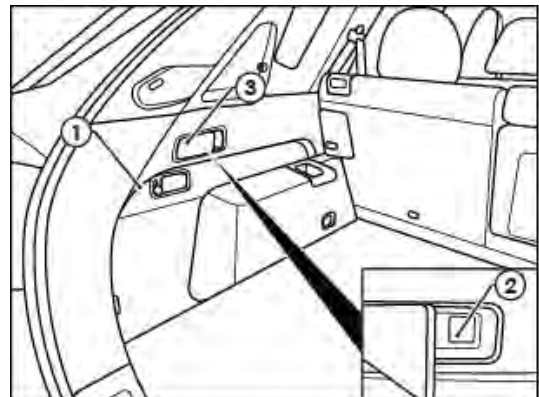

-
27. Locate the Pre-wire connectors (1) behind the Left Rear Compartment trim and remove the tape securing them.

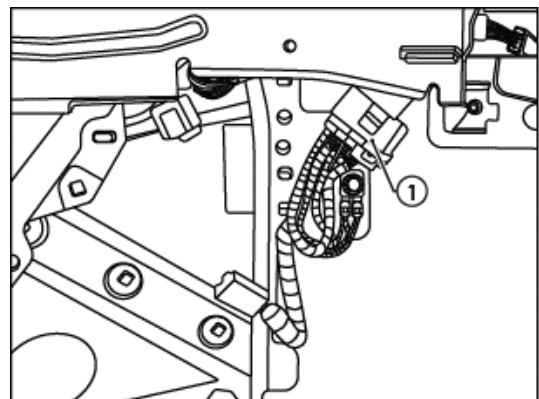

28. Connect the Trailer Wiring Harness Connectors (1) to the Mating Pre-wire Connectors (2).

29. Secure Ring Terminal to the vehicle earthing point (3).

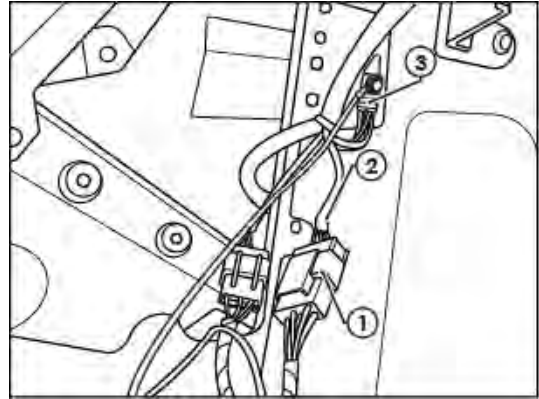

30. Using an alcohol wipe, clean the LHS inner sheet (1) metal area and the underside of the ECU (04826) (2).

31. Connect the trailer patch 12-way connector (3) to the ECU.

32. Apply double sided tape to the ECU (2) and secure it to the vehicle sheet metal.

Note: Mount the ECU, ensuring the connector is orientated downwards.

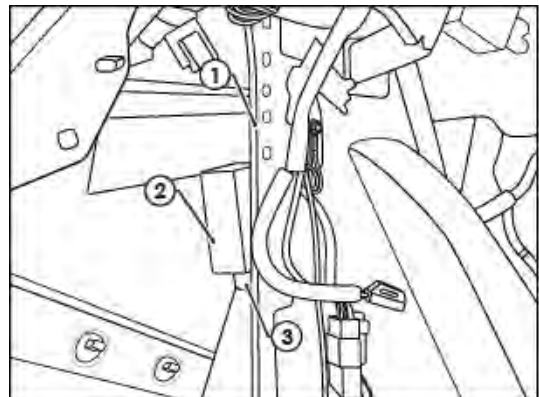

33. Drill a 30mm grommet hole in a location indicated (1) in the image to enable the tail harness to be routed from the towbar to the ECU.

Note: File any rough or sharp edges, spray rust inhibitor

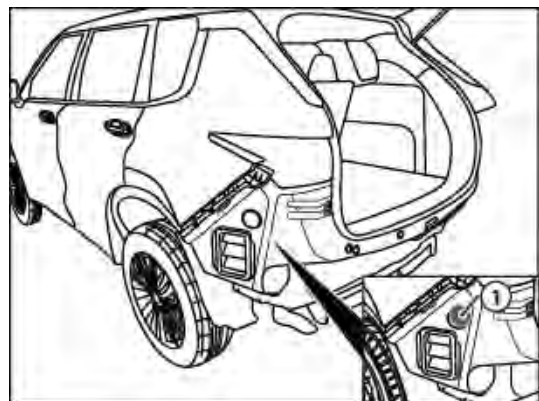

34. With the rear bumper removed, secure tail harness to towbar.
35. Route tail harness up through chassis and previously drilled 30mm hole.
36. Seat grommet in 30mm hole and route to trailer harness blue connector on patch loom.

Note: Keep harness routing clear of all sharp edges, moving parts and places of extreme heat.

Note: Ensure grommet is seated correctly and makes a good seal.

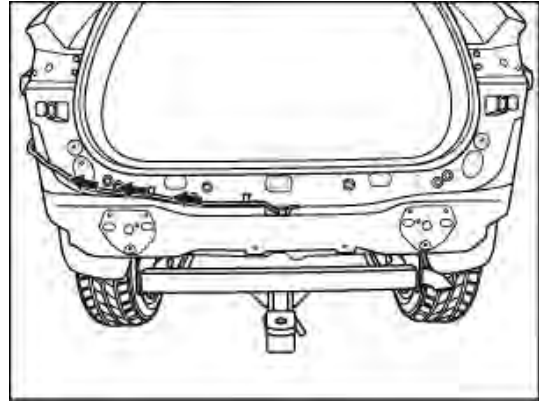

37. Connect the tail harness (tail length 1200mm) 8-way connector (1) to the trailer patch mating 8-way connector (2).
38. Cut-off, crimp the tail harness GREY (3) and GREY/BLACK wires (4) to the trailer patch matching GREY (5) and GREY/BLACK wires (6).
39. Secure all harness using supplied cable ties.
40. Test the trailer patch function using a light board or multimeter.
41. Re-fit all removed parts and secure all fasteners, ensuring there are no squeaks or rattles. From Step 1-10, 19-28 in reverse.
42. Place the fitting instructions in the glove box after fitment.

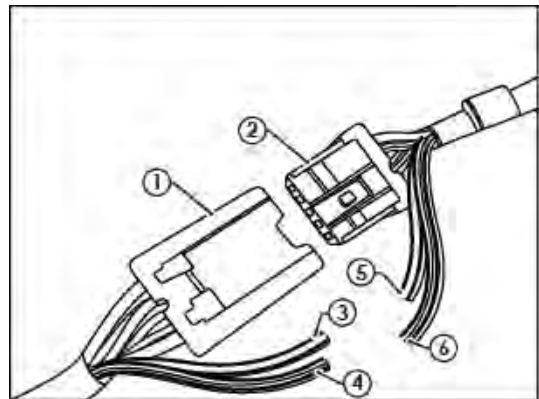



CUSTOMER INFORMATION

PLACE THESE INSTRUCTIONS IN THE VEHICLE'S GLOVEBOX AFTER INSTALLATION

THANK YOU FOR PURCHASING TRAILBOSS. WITH CORRECT MAINTENANCE AND CARE THIS PRODUCT WILL PROVIDE A LIFETIME OF TROUBLE-FREE OPERATION.

TOWBAR MAINTENANCE AND CARE:

1. Trailboss recommend that the towbar LUG or TBM (Trailer Ball Mount) Pull Pin and R-clip are removed and stored when not in use. Removal of LUG or TBM (Trailer Ball Mount) is advisable when not in use to assist with any of the following.
 - Ensure rear number plate is not obscured.
 - Allow maximum available departure angle and prevent any potential interference.
 - Prevent possible interference with vehicles reverse sensors or camera detecting a tow ball mount as an obstruction during reversing.
 - Removes towball mount as an obstruction for when moving around the rear of the vehicle.
2. Trailboss recommends routine inspection of your towbar to ensure trouble free towing.
 - Bolt security and tension should be regularly inspected and checked for correct tension. Replace any worn or defective parts with suitable grade & class fasteners. Inspection should be requested to coincide with vehicle major services.
3. It is the owner's responsibility to ensure towing and down ball weight capacities of the towing vehicle are not exceeded.
 - Towing and down ball weights allowable may differ according to model variations. Please refer to owner's manual or vehicle dealer to confirm exact rating for your vehicle model variant.
 - It is not uncommon for the vehicle tow rating to differ from the towbar rating. When this occurs, the lesser rating must be adhered to.
 - For vehicles fitted with enhanced vehicle functions that may be altered/changed when towing i.e Trailer sway mitigation, blind spot detection, adaptive cruise control etc. Please consult owner's manual to understand changes enabled when towing and after towing.

WARRANTY INFORMATION:

Trailboss Towbars are covered by a Lifetime Warranty.

Our goods come with guarantees that cannot be excluded under the Australian Consumer Law. You are entitled to a replacement or refund for a major failure and for compensation for any other reasonably foreseeable loss or damage. You are also entitled to have the goods repaired or replaced if the goods fail to be of acceptable quality and the failure does not amount to a major failure.

For further details please contact customer service on 1800 812 017.

PRO SERIES SILENT ANTI-RATTLE HITCH PIN

Your Trailboss towbar is equipped with a Pro Series Silent Anti-Rattle Hitch Pin technology to help reduce towbar tongue rattle in most driving conditions. Please ensure below instructions are understood and routine maintenance is carried out to ensure best towing experience.

Regularly inspect for wear and check the tightness of the Silent Anti-Rattle Hitch Pin. Follow instructions below to re-tighten the nut as necessary when movement and noise in the tow ball mount is noted.

- Before towing, ensure R-Clip is properly installed and hitch pin nut is installed and tensioned. Replacement parts are available from your Pro Series Distributor.

TOWBALL MOUNT REMOVAL/INSTALLATION

STEP 1

Insert Trailer Ball Mount (TBM) (a) into towbar hitchbox (b), aligning hole in TBM shank (c) with hole in hitchbox (d) (Fig. 1)

STEP 2

Insert Silent Anti-Rattle Hitch Pin (e) through hole in hitchbox and hole in TBM shank (g); ensure the locators are inserted into the notches in the hitchbox (Fig. 2)

STEP 3

Screw Silent Anti-Rattle Hitch Pin Nut (f) onto Smart Pin (g); tighten Smart Pin Nut until finger tight, ensuring TBM is restrained from up and down movement.

STEP 4

Tighten Silent Anti-Rattle Hitch Pin Nut by turning nut a further 1/8th of a turn in the clockwise direction using a 24mm spanner (Fig. 4).

STEP 5

Install Silent Anti-Rattle Hitch Pin R-Clip through the hole that provides best clearance or easiest access. (Fig. 5)

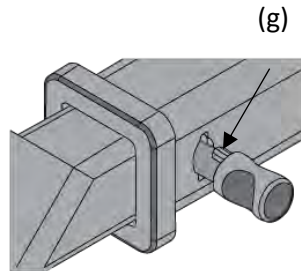
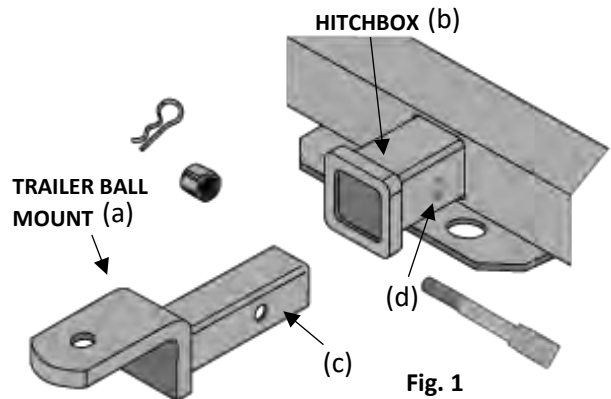

Fig. 2

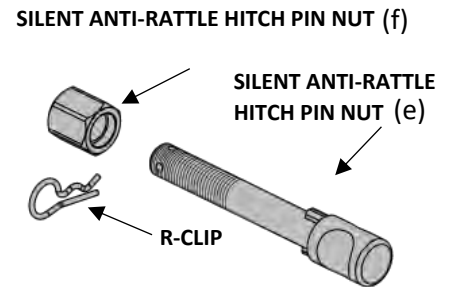

Fig. 3

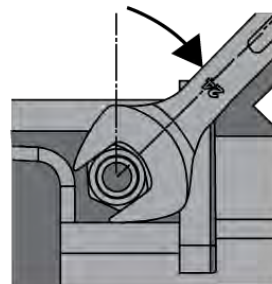

Fig. 4

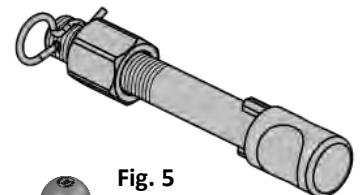

Fig. 5

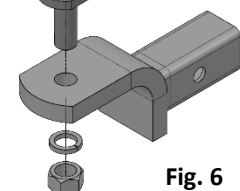

Fig. 6