



Towbar Fitting Instructions
To Suit Nissan Navara D40 Dual Cab with no bumper step 2010-on
Part Number QTDS845L
Rating 3000 kg

WARNING:

1. Do not, drill, cut, weld or otherwise modify the tow bar.
2. If you are using electric welding on a motor vehicle, **always** check that the vehicle is not equipped with electronic engine or instrument management equipment. Failure to do so could **destroy** any onboard computers. If in doubt, check with the vehicle's manufacturer.

- 1 Ensure all hardware items have been included.
- 2 Offer tow bar to rear of vehicle so to align slots in side plates with captive nuts on the underside of the chassis rails see fig 1.
- 3 Then fasten with M12 x 1.25 pitch bolts, flat & spring washers supplied as per diagram on the next page.
- 4 Fit all hardware as per diagram on the next page.
- 5 Tighten all nuts & bolts to torque listing below.

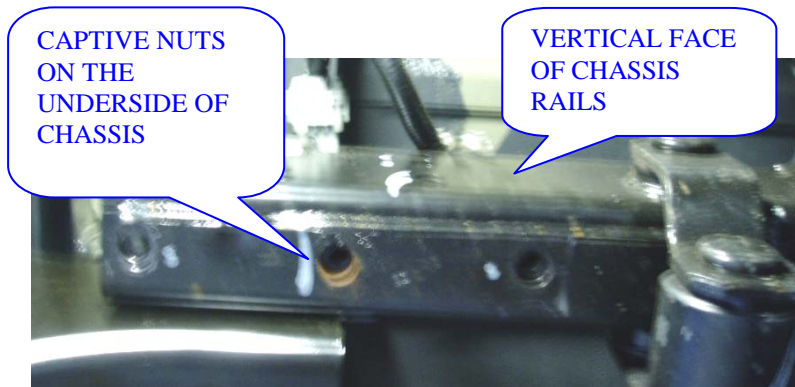

FIG 1

NOTE: Trailboss recommends that you check your towball to ensure it complies with the Australian standard AS 4177.2.

RECOMMENDED ASSEMBLY TORQUE LISTING

Diameter Grade 8.8 Bolt

	Nm;
M6	9.5
M8	21.7
M10	43.4
M12	77.3
M16	189.8

FOR TOWING PURPOSES ONLY
For towing capacity details please refer to vehicle owner's manual or to the manufacturer. Overloading can void your warranties.

TRAILBOSS

Towbar Fitting Instructions To Suit Nissan Navara D40 Dual Cab with no bumper step 2010-on Part Number QTDS845L Rating 3000 kg

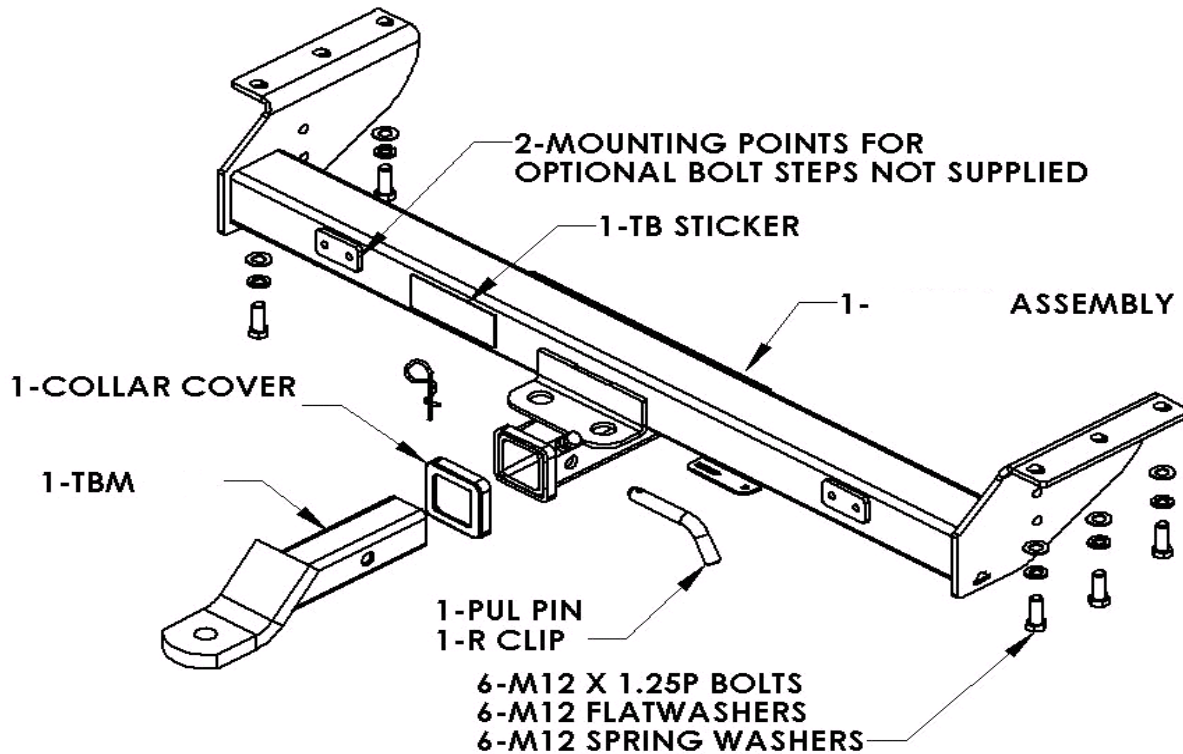

TOWBALL WEIGHT NOTES:

As per motor vehicle manufactures specification the towing capacity is subject to tow bar/towball capacity. The permitted download is directly related to the laden mass of vehicle. The maximum towball download is 300kg.

2WD Model

Towball download	Vehicle mass
70kg	GVM (all variants)
100kg	Reduced loaded vehicle mass below GVM by 40kg
150kg	Reduced loaded vehicle mass below GVM by 110kg
200kg	Reduced loaded vehicle mass below GVM by 180kg

4WD Model

Towball download	Vehicle mass
150kg	GVM (All variants)
200kg	Reduced loaded vehicle mass below GVM by 60kg
250kg	Reduced loaded vehicle mass below GVM by 130kg
300kg	Reduced loaded vehicle mass below GVM by 200kg

If the loaded vehicle mass is reduced as shown in the table, the towball download can be increased correspondingly. Accordingly, if the laden mass is 180kg less than the GVM, a towball download of 200kg is approved (2WD).

Different trailer types and different trailer manufacturers have varying towball downloads. The customer will need to contact the trailer manufacturer for information as to the download.

GVM includes the driver, 4 passengers, full fuel tank and luggage.

CAPACITY	4x2 ST-X Petrol	4x4 RX Petrol	4x4 RX Diesel	4x4 ST-X Petrol	4x4 ST-X Diesel
	2000/200	3000/300	3000/300	3000/300	3000/300



Wiring Loom Fitting Instructions
To Suit Nissan Navara D40
Part Number 100474-WL
January 2010 Onwards

Wiring Loom Installation Instructions

Nissan Navara D40
January 2010 Onwards
Part No: 100474-WL

Tail Harness Length Required: 1200mm
RPA Override Switch Part No: 04848 (If Fitted)

Wiring Loom Installation Time: Approx 10 Mins



Wiring Loom Fitting Instructions
To Suit Nissan Navara D40
Part Number 100474-WL
January 2010 Onwards

1. At the rear LHS of the vehicle underneath the tray, disconnect the tail light connectors and patch the trailer patch harness (P/No: 100474-WL) connectors in between.
2. On the tail harness (Tail length 1200mm) and mating connector, apply electrical grease or silicon on to the back of the connectors to make them water proof. Connect the tail harness and trailer patch harness connectors together.
3. Route the tail harness along the main body harness towards the trailer socket mounting bracket. Secure the tail socket onto the mounting bracket using M4 fasteners (not supplied).
4. Secure all harnesses to the vehicle using cable ties (not supplied).
5. Test the Trailer Harness function using trailer light board or multimeter.
6. Refit all removed parts and secure all fasteners.
7. Please place the fitting instructions in the glove box after installation.