

TRAILBOSS

Towbar Fitting Instructions

To Suit **NISSAN JUKE F15 SERIES - 2WD VARIANT ONLY**

Part Number **QTDS857L**

Rating **1250/125 kg**

PLACE THESE INSTRUCTIONS IN THE VEHICLE'S GLOVEBOX AFTER INSTALLATION IS COMPLETED

WARNING:

1. Do not, drill, cut, weld or otherwise modify the tow bar.
2. If you are using electric welding on a motor vehicle, **always** check that the vehicle is not equipped with electronic engine or instrument management equipment. Failure to do so could **destroy** any onboard computers. If in doubt, check with the vehicle's manufacturer.
3. The high tensile fasteners supplied with this product were used to achieve the specified rating. If replacement is required ensure that fasteners of the same rating & quality are used. Contact an authorised **Trailboss** dealer if further information is required.
4. If TBM is used in inverted position tow ball may make contact with rear tailgate when lowered, which could cause damage.

General:

1. Ensure all hardware items have been included refer to assembly diagram.
2. It is recommended that the instructions are read through and completely understood before making any attempt to fit this product.
3. Be wary of any changes to vehicle designs or other accessories that may conflict with the installation of this product.
4. Before drilling ensure that the area is clear of fuel, electrical & other components.
5. All holes drilled into the body panels shall have all burrs & swarf removed then coated with a suitable rust preventative paint.
6. For vehicles that require the bumper to be cut. Ensure cut out area is in correct position on the vehicle prior to cutting the bumper.
7. The high tensile fasteners supplied with this product were used to achieve the specified rating. If replacement is required ensure that fasteners of the same rating & quality are used. Contact an authorized **Trailboss** dealer if further information is required.
8. Ensure that all hardware is fastened to torque list below check fasteners on regular basis.
9. Tow bar load rating sticker provided with this product shall be conspicuously located on inside rear end of the driver's door. **(See diagram below).**
10. Trailboss recommends that you check your tow ball to ensure that it complies with the Australian standards **AS 4177.2**.
11. **PLEASE NOTE:** It is advised to remove your lug or tbn when not actually towing so as to produce a clear view of the vehicles registration plate if obscured, and to also provide maximum available departure angle
12. Pull Pin must be fit in down position.

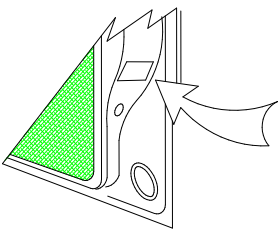

Place load rating sticker
inside driver's door here

FOR TRAILER TOWING PURPOSES ONLY
For towing capacity details please refer to vehicle owner's manual or to the manufacturer. Overloading can void your warranties.

RECOMMENDED ASSEMBLY TORQUE LISTING

Diameter	Grade 8.8 Bolt
M6	9.5 Nm
M8	21.7 Nm
M10	43.4 Nm
M12	77.3Nm
M14	146 Nm
M16	189.8 Nm

Tow bar Maintenance and Care.

Trailboss recommends that bolt torque's, as listed below, are routinely and regularly inspected and checked for correct tension. Replace any worn or defective parts.

We recommended to remove Tow Ball Mounts (TBM's, tongues or lugs) when not being used for any considerable length of time.

So as to avoid injury, when not towing it is suggested that the tongue, Pull Pin and R-clip are removed then stored in a safe, clean and dry place, away from excessive moisture.

Hitch Pull Pins and spring "R" clips are regularly checked for proper installation. Replace any worn or defective parts.

TRAILBOSS

Towbar Fitting Instructions

To Suit **NISSAN JUKE F15 SERIES - 2WD VARIANT ONLY**

Part Number **QTDS857L**

Rating **1250/125 kg**

PLACE THESE INSTRUCTIONS IN THE VEHICLE'S GLOVEBOX AFTER INSTALLATION IS COMPLETED

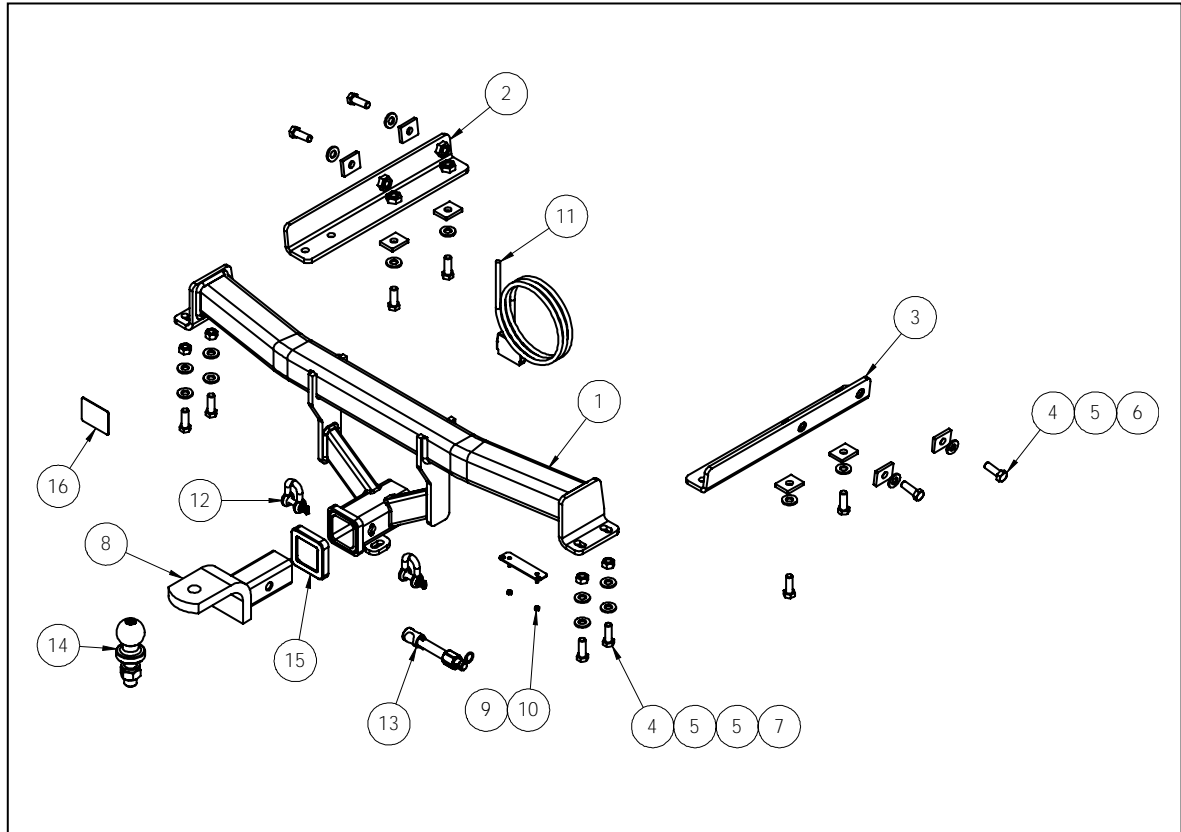

QTY.	DESCRIPTION	ITEM NO.
1	NISSAN JUKE 2WD WELDED ASSY	1
1	CHASSIS NISERT LHS	2
1	CHASSIS INSERT RHS	3
12	SET SCREW M12-1.25x35	4
16	WASHER FLAT 1/2"x1 1/8"x1/8"	5
8	LOOSE PLATE 32x6x40 Ø13	6
4	HEX NUT M12x1.25 PC8	7
1	TBM ASSY	8
1	PLUG BRACKET	9
2	NUT NYLOC M4-0.7 Z/P	10
1	WIRING LOOM	11
2	10mm "D" SHACKLE	12
1	SILENT HITCH PIN-SILVER	13
1	50mm TOWBALL	14
1	HITCH BOX COLLAR COVER	15
1	ACRYLIC COMPLIANCE PLATE	16



Towbar Fitting Instructions
To Suit **NISSAN JUKE F15 SERIES - 2WD VARIANT ONLY**
Part Number **QTDS857L**
Rating **1250/125 kg**

PLACE THESE INSTRUCTIONS IN THE VEHICLE'S GLOVEBOX AFTER INSTALLATION IS COMPLETED

INSTRUCTION:

1. Release the rear tail gate to expose the boot.
2. Remove 4 x Set Screws; two are located on the tail light and additional two on the bumper below the tail light. Keep in a safe place for re-assembly. Perform for Passenger and Driver side.
3. Carefully remove and disconnect the tail light. Keep in a safe place for re-assembly. Perform for Passenger and Driver side.
4. On the inside of the guard liner, remove 3 x Push Clips. Remove bottom guard liner. Perform for Passenger and Driver side.
5. Carefully remove the outer guard moulding, by releasing the internal tab and peeling the moulding away.
Remove 1 x Screw securing the bumper to the rear quarter panel. Perform for Passenger and Driver side.
6. Remove 6 x Push Rivets located on the bottom lip of the bumper.
Carefully remove the bumper by peeling away at each side. Disconnect the centre reflector plug and any factory fitted reverse parking sensors. Keep the bumper in a safe place for re-assembly.
7. Remove and discard, foam reinforcement, impact beam and lower plastic infill panel.
Impact Beam: Remove 6 x Set Screws securing it to the back panel of the vehicle. Re-install Set Screws after discarding impact beam. Bottom Plastic Infill Panel: Remove 3 x Push Rivets.
8. Open up chassis rail cavities on the rear panel to allow chassis inserts to slide in freely. Cut back each corner to chassis rail face, fold back and cut flanges off. Apply rust inhibitor to any raw surface from cutting.
9. Using a step drill or equivalent, expand mounting point holes to 14mm for suitable clearance.
Notch inner guard seam obstructing the most forward horizontal mounting point, to allow for a 18mm socket head.
10. Insert respective side arms into chassis rails. Loosely secure side arms using 4 x M12x35 x 1.25P Set screws, complete with 4 x Washer Plates and 4 x Flat Washers.
11. With the side arms in place, prop the centre section of the Towbar on top of the side arms. Centre the Towbar and loosely secure using 4 x M12 x 35 x 1.25P Set Screws, complete with 8 x Flat Washers and 4 x M12 x 1.25P Nuts.
Torque all fasteners to the following specifications:
M12 x 35 x 1.5P : 90Nm
12. Using the centre fog light as a reference, locate the centre of the bumper. Carefully cut 230mm wide (115mm either side of the centre) and 30mm up from the edge of the bumper.

Then cut an additional 90mm wide (45mm either side of the centre) and 30mm up from the edge of the previous cut.



Towbar Fitting Instructions

To Suit **NISSAN JUKE F15 SERIES - 2WD VARIANT ONLY**

Part Number **QTDS857L**

Rating **1250/125 kg**

PLACE THESE INSTRUCTIONS IN THE VEHICLE'S GLOVEBOX AFTER INSTALLATION IS COMPLETED

13. Mark out and drill 2 x 5mm holes 69mm apart onto bumper skin to support plug bracket. Feed bracket threads through drilled holes prior to reinstalling bumper.
14. Re-Install bumper by following steps 1-6 in reverse order.



Wiring Loom Fitting Instructions
To Suit Nissan Juke Series 2 MY15
Part Number 100937-WL

Wiring Loom Installation Instructions

Nissan Juke Series 2 MY15
Part No: 100937-WL

Tail Length Required: 1200mm

Wiring Loom Installation Time: Approx 30 Mins



Wiring Loom Fitting Instructions
To Suit Nissan Juke Series 2 MY15
Part Number 100937-WL

1. In the luggage compartment, remove the floor cover carpet and fold the rear seats forward.
2. Remove the rear compartment trim.
3. Fold down the rear seats.
4. On the RHS luggage compartment, remove the fastener and then dislodge the trim. Repeat for the LHS.
5. Disconnect the LHS tail light connectors and patch the trailer patch (P/No: 100937-WL) in between.
6. Route the trailer patch harness RHS branch along the rear of the luggage compartment towards the RHS tail light connectors.
7. Disconnect the RHS tail light connectors and patch the trailer patch (P/No: 100937-WL) in between.
8. Secure the trailer patch ground ring terminal to a suitable location on the vehicle using a tek screw (not supplied).
9. At the vehicle RHS rear quarter, locate a suitable location on the sheet metal floor and drill a Ø30mm hole. File down any rough or sharp edges and spray with rust inhibitor (not supplied).
10. At the rear exterior of the vehicle, mount the tail harness socket to the towbar mounting bracket using M4 fasteners (not supplied).
11. Route the tail harness (tail length: 1200mm) across the RHS and into the drilled out grommet hole. Adjust the trailer patch harness grommet so that it is seated correctly and cable tie (not supplied) in place.
12. Inside the vehicle, connect the tail harness 8-way connector to the trailer patch 8-way mating connector.
13. Test the body harness using a light board or multi-meter.
14. Secure all harnesses using cables ties (not supplied).
15. Re-fit all removed parts and secure all fasteners.
16. Place instructions in glove box after fitment.



FITTING INSTRUCTIONS

Silent Anti-Rattle Hitch Pin (PR0001)

• These fitting instructions are supplied to ensure understanding of how the HITCH PIN should be fitted and used correctly.

• Once installed, we recommend **ALL** instructions are kept and placed in the vehicle glove box.

NOTE: Routine maintenance and inspection of the towbar & HITCH PIN is required. Regularly inspect for wear and check the tightness of the Hitch Pin. Follow instructions below to retighten the nut when necessary.

***Do not tow with your vehicle if the R CLIP or the HITCH PIN is loose or missing. Replacement parts are available from your Pro Series Distributor.**

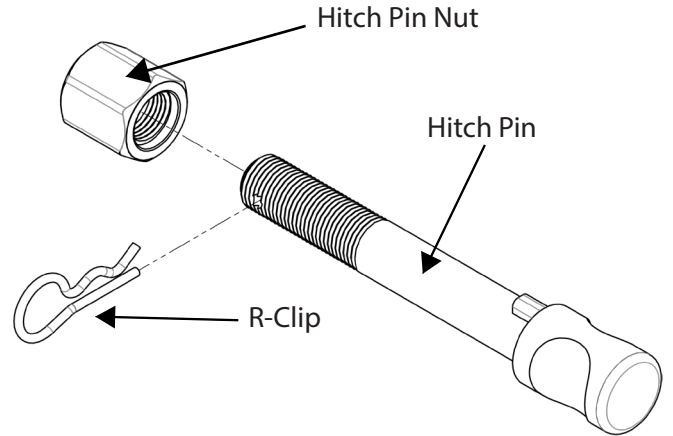

Fig 1. Silent Anti-Rattle Hitch Pin assembly

STEP 1

Insert Trailer Ball Mount (TBM) into towbar HITCHBOX, aligning hole in TBM SHANK with hole in HITCHBOX (Fig 2).

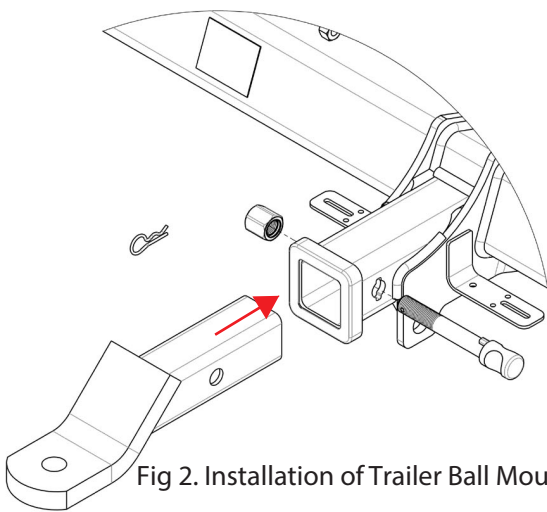

Fig 2. Installation of Trailer Ball Mount

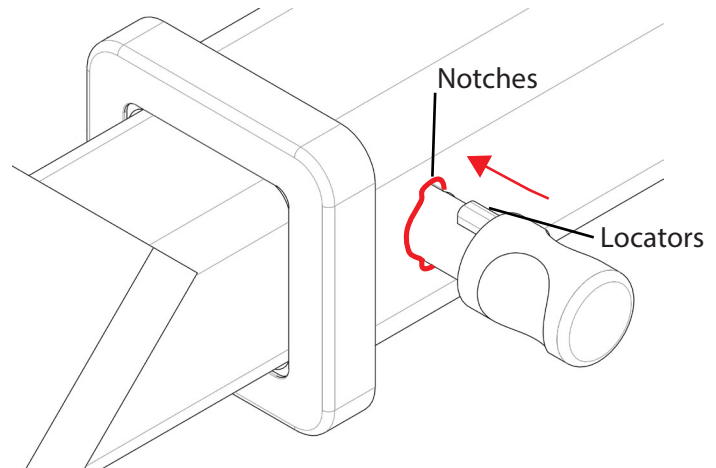

Fig 3. Silent Anti-Rattle Hitch Pin orientation

STEP 2

Insert HITCH PIN through hole in HITCHBOX and hole in TBM SHANK; ensure the LOCATORS are inserted into the NOTCHES in the HITCHBOX (Fig. 3).

STEP 3

Screw HITCH PIN NUT onto HITCH PIN; tighten HITCH PIN NUT until finger tight, ensuring TBM is restrained from movement.

STEP 4

Tighten HITCH PIN NUT by turning nut a further 1/8th of a turn in the clockwise direction using a 24mm spanner (Fig. 4).

STEP 5

Install HITCH PIN R CLIP through the hole on the HITCH PIN (Fig. 1).

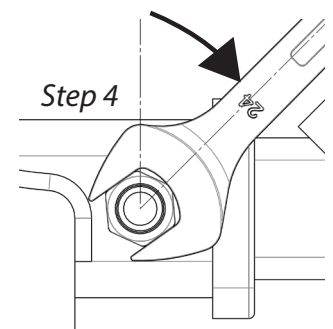

Fig 4. Tightening of Silent Anti-Rattle Hitch Pin Nut