

TRAILBOSS

Towbar Fitting Instructions To Suit Ford Territory TX 04/2004 On Part Number QTFD1600L Rating 2700Kg

WARNING:

FORD MOTOR COMPANY RECOMMENDS THE USE OF A LOAD LEVELING KIT TO ACHIEVE THE MAXIMUM TOWING CAPACITY

Do not, drill, cut, weld or otherwise modify the towbar.

If you are using electric welding on a motor vehicle, **always** check that the vehicle is not equipped with electronic engine or instrument management equipment. Failure to do so could **destroy** any onboard computers. If in doubt, check with the vehicle's manufacturer.

- 1 Ensure all hardware items have been included.
- 2 Remove tail lights, via removal of the following items:
 - a) 6-torx head screws 3 each tail light or Phillips head screws
 - b) Unplug tail light connection for each light
 - c) 2-10mm nuts behind lights
 - d) Removal of tail lights for **FORD TERRITORY SZ 2011 On** models, refer to diagrams below.



Remove screw from light assembly. Grip light assy and pull towards you, allowing clip to pop off housing. Remove tail light from vehicle.



Clip housing button

- 3 Remove bumper bar, via removal of the following items:
 - a) 2-plastic trim plugs and 2 screws on underside of each wheel arch
 - b) If mudguards are fitted, screws replace trim buttons
 - c) 7-plastic trim buttons on underside of bumper bar
 - d) If reverse sensors are fitted, disconnect
 - e) Flex out bumper bar from sides and pull rear ward
- 4 Cut rear panel as per diagram with tin snips, and then fold section of panel up and flat. (see Figures 1 & 2)
- 5 Lift bar into position, so holes in side plates of towbar align with holes in sub frame. Support the bar with jack stands or jack and drive through taptite bolts in six places using suitable rattle gun. (see page 2 for more information)
- 6 Make sure that all six mounting points in sub frame have been accounted for.
- 7 Tighten all bolts on impact beam to specified torque.
- 8 Fit loose mounting arms to towbar. The longer of the two to the passenger side and the shorter to driver's side, making sure that the spacer tubes are fitted between the bar and the loose arms.
- 9 Tighten bolts semi tight, making sure that the arms are square and straight to sub frame.
- 10 Using holes in loose arms as a guide drill 13mm on underside of chassis rails in three places on passenger side, and two places on driver's side.
- 11 Feed support chassis brackets through holes in chassis rails, then align with the holes drilled in step 10.

TRAILBOSS

Towbar Fitting Instructions To Suit Ford Territory TX 04/2004 On Part Number QTFD1600L Rating 2700Kg

- 12 Fit bolts and washers as per diagram.
- 13 Tighten all bolts to torque listing below then cut excess wire from nuts and bolts.
- 14 Fit plastic inserts into access holes as per fitting diagram.
- 15 Cut bumper as per figure 3 and fit pinch weld.
- 16 Remove and discard screws in 2 places, and trim off plastic tabs.
- 17 Refit bumper by following step 3, then step 2.

RECOMMENDED ASSEMBLY TORQUE LISTING

Diameter Grade 8.8 Bolt

	Nm
M8	21.7
M10	43.4
M12	77.3
M16	189.8

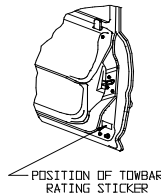

FOR TOWING PURPOSES ONLY

For towing capacity details please refer to vehicle owner's manual or to the manufacturer. Overloading can void your warranties.

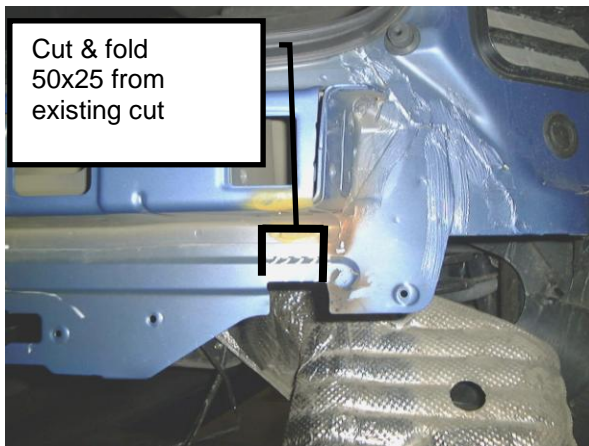

FIG 1 DRIVERS SIDE

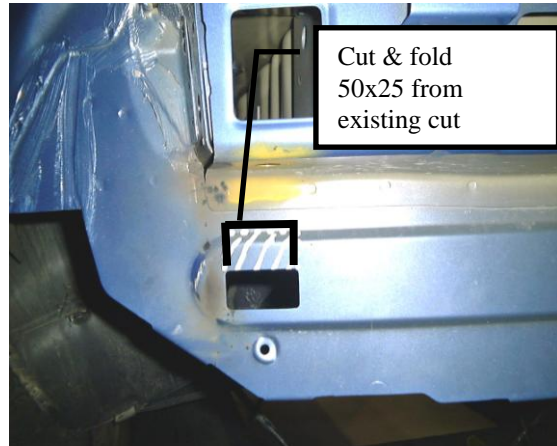
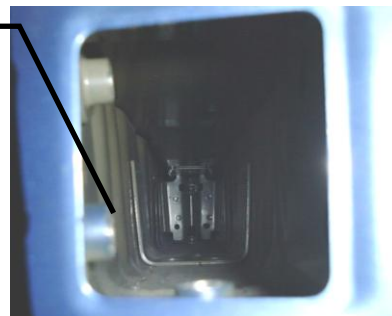

FIG 2 PASSENGER SIDE

FITTING TAPTITE BOLTS

Captive bushes,
Three each side.

- Lift bar into position so holes in sub frame line up with holes in side arms.
- Support tow bar with suitable jack or jack stands, as per step 5.
- Drive tap tite bolts supplied into captive bushes in three places, two located at each end of sub frame and one underneath each side, with suitable rattle gun.
- Loosen tap tite bolts so that the bar can be manipulated into the correct position.



TRAILBOSS

Towbar Fitting Instructions
 To Suit Ford Territory TX 04/2004 On
 Part Number QTFD1600L
 Rating 2700Kg

FIG 3 BUMPER CUT

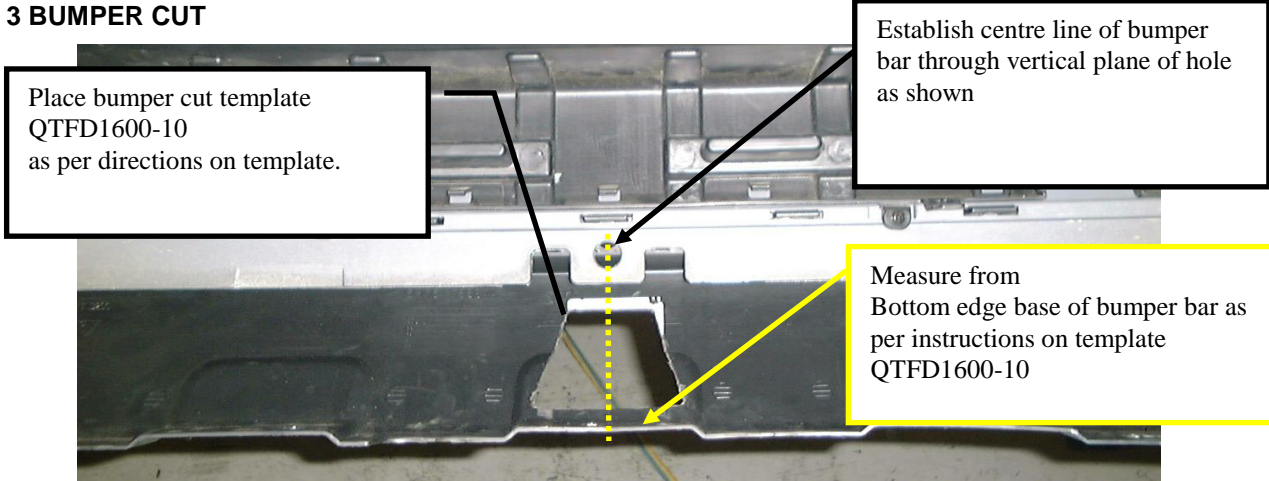

PLEASE NOTE: You must remove the lug unless you are actually towing if it obscures your number plate. Failure to do so may result in a fine.

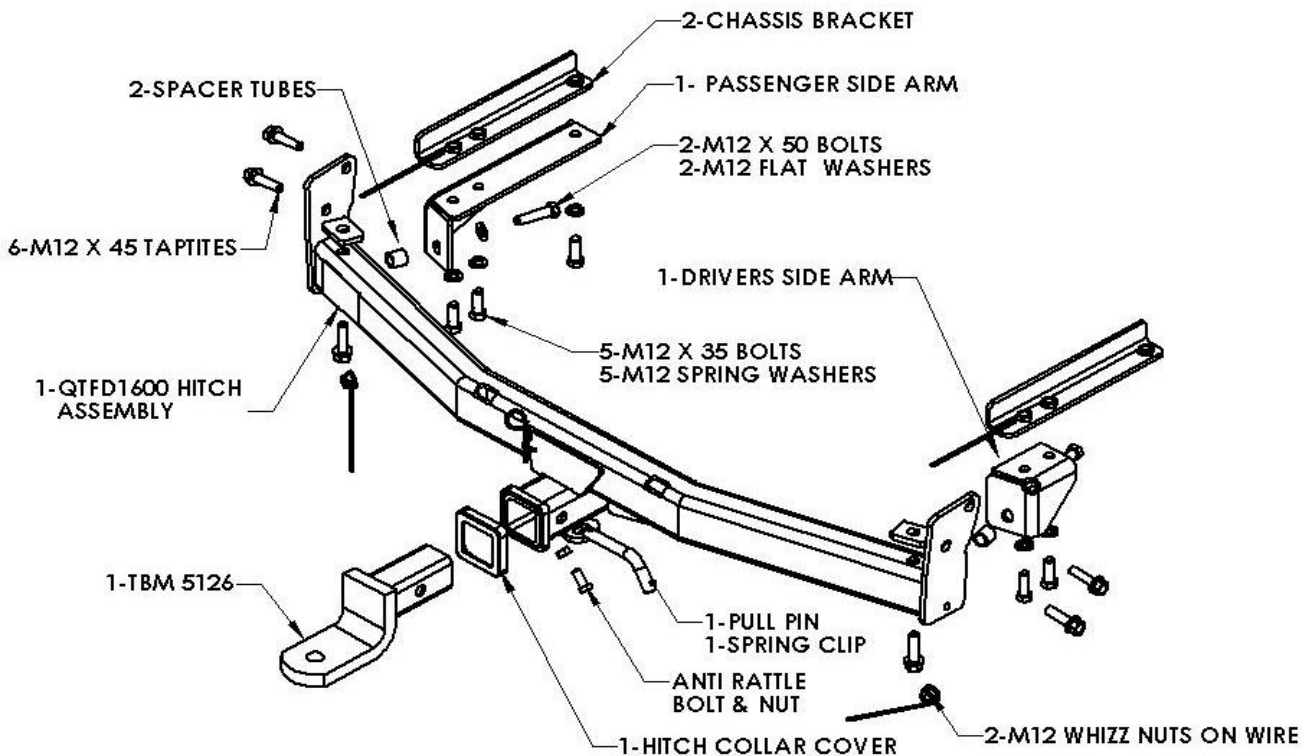

ESTABLISH CENTRE LINE OF BUMPER AS PER FIG 3 FROM INSTALLATION INSTRUCTIONS QTFD1600

NOTE:
PLEASE ENSURE TEMPLATE IS TO SCALE BEFORE CUTTING BUMPER.

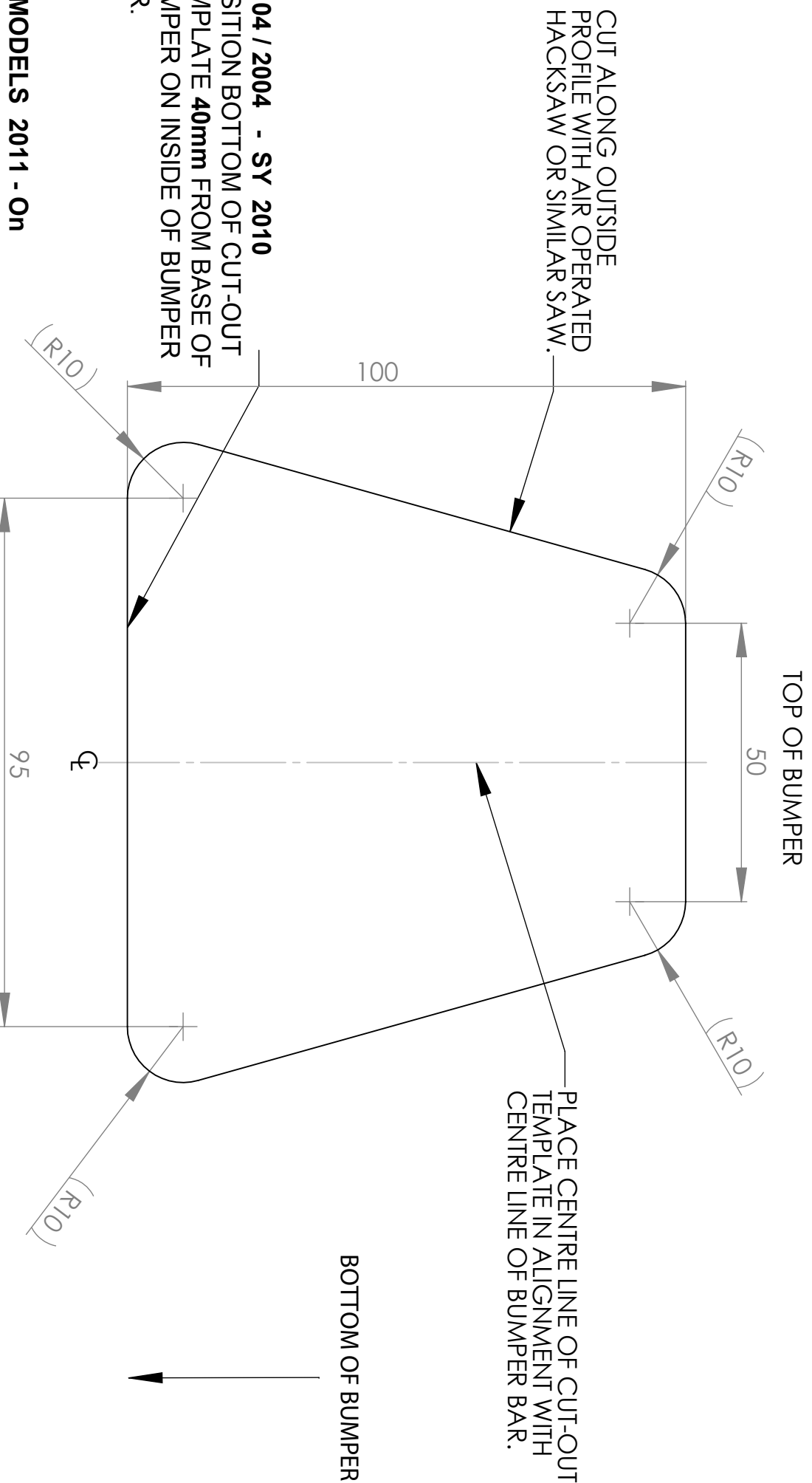

TX 04 / 2004 - SY 2010
POSITION BOTTOM OF CUT-OUT
TEMPLATE **40mm** FROM BASE OF
BUMPER ON INSIDE OF BUMPER
BAR.

SZ MODELS 2011 - On
POSITION BOTTOM OF CUT-OUT
TEMPLATE **45mm** FROM BASE OF
BUMPER ON INSIDE OF BUMPER
BAR.

DRILL THROUGH 20mm IN EACH CORNER TO ACHIEVE
10mm RADIUS. OUTSIDE OF DRILL BIT SHOULD BE CONCENTRIC
WITH CORNER PROFILE.



Wiring Loom Fitting Instructions
To Suit Ford
BA/BF Falcon Sedan
Wagon AU123 BA (Sept onwards)
Falcon AU Sedan (Sept 1998 to Aug 2002)
BA/BF/XR6/Xr8 Sedan
AU Falcon Sedan (Sept 1998 to Sept 2002)
Territory
Part Number 100001-WL

Wiring Loom Installation Instructions

Ford
Part No: 100001-WL

Tail Harness Length Required: 1200mm
RPA Override Switch Part No: 04848 (If Fitted)

Wiring Loom Installation Time: Approx 10 - 40 Mins depending on
vehicle model.



Wiring Loom Fitting Instructions
To Suit Ford
BA/BF Falcon Sedan
Wagon AU123 BA (Sept onwards)
Falcon AU Sedan (Sept 1998 to Aug 2002)
BA/BF/XR6/Xr8 Sedan
AU Falcon Sedan (Sept 1998 to Sept 2002)
Territory
Part Number 100001-WL

Sedan Steps:

1. In the luggage compartment, remove the necessary trims to gain access to the RHS tail lights.
2. Connect the Trailer Patch Harness (P/No: 100001-WL) connector to the vehicle break out connector.

BA/BF Sedan models only:

3. At the RHS rear quarter of the vehicle, remove the vehicle grommet.
4. From outside of the vehicle, route in the Tail Harness (length 1200mm) through the grommet hole and connect it to the Trailer Patch Harness connector. **Note: If vehicle is fitted with an RPA kit, drill a Ø30mm access hole near the existing grommet for Tail Harness routing.**
5. Route the Tail Harness socket towards the towbar mounting bracket.
6. Secure the Tail Harness socket onto the towbar mounting bracket using M4 fasteners.

AU Sedan models only:

7. Locate the RHS grommet near the spare wheel well.
8. Mount the Trailer Socket to the towbar using M4 Fasteners then route the Tail Harness (length 1200mm) over to the grommet hole then feed it into the vehicle.
9. From underneath the vehicle, route the Tail Harness (tail length 1800mm) into the vehicle. Slide the grommet to the desired position and then cable tie inside the vehicle. Press the grommet in place, ensuring a good seal is obtained. Then secure the grommet in place with a cable tie (not supplied).
10. In the luggage compartment, connect the Tail Harness to the Trailer Harness Patch.

Test the Tail Harness socket using a light board or multimeter.

11. Secure all harnesses using cables ties.
12. Refit all removed parts and secure all fasteners ensuring there are no squeaks or rattles.
13. Place instructions in glove box after fitment.

Wagon models only:

14. On the RHS trim remove the Jack Access panel and locate the 8-way trailer breakout connector.



Wiring Loom Fitting Instructions
To Suit Ford
BA/BF Falcon Sedan
Wagon AU123 BA (Sept onwards)
Falcon AU Sedan (Sept 1998 to Aug 2002)
BA/BF/XR6/Xr8 Sedan
AU Falcon Sedan (Sept 1998 to Sept 2002)
Territory
Part Number 100001-WL

15. Plug the Trailer Harness Patch (P/N 100001-WL) to the 8-way trailer breakout connector.
 16. In the jack access cavity area, remove the grommet blanking plug from the RHS rear quarter.
 17. Outside, at the rear of the vehicle, mount the Trailer Socket to the towbar using M4 fasteners.
 18. From underneath the vehicle, route the Tail Harness (length 1200mm) over to the grommet hole then feed it through the grommet hole and into the vehicle. **Note: The grommet must be moved along the harness to the desired location.**
 19. Press the grommet in place, ensuring a good seal is obtained. Then secure the grommet in place with a cable tie (not supplied).
 20. Inside the vehicle, connect the Tail Harness connector to the trailer patch. Cable Tie back any excess length.
 21. Test the Trailer socket using a light board or multi-meter.
 22. Secure the all harnesses using cables ties.
 23. Refit all removed parts and secure all fasteners.
 24. Place instructions in glove box after fitment.
- Territory models only:**
25. Remove the necessary trims to gain access to the RHS vehicle 8-way break out connector then connect the Trailer Patch harness (P/No: 100001-WL) to the break-out connector.
 26. On the RHS rear, below the tail light, remove the grommet and feed the Tail Harness (Length 1200mm) through the hole until it comes through the inner cavity.
 27. Connect the Trailer Patch Harness to the Tail Harness.
 28. On the outside rear of the vehicle, secure the trailer socket onto towbar mounting plate using M4 fasteners.
 29. Test the Trailer socket using a light board or multi-meter.
 30. Secure the all harnesses using cables ties.
 31. Refit all removed parts and secure all fasteners.
 32. Place instructions in glove box after fitment.