

TRAILBOSS

Towbar Fitting Instructions
To Suit **FORD TRANSIT VAN SERIES 11/2000-02/2014**
Part Number **QTFD1919L**
Rating **3000/300 kg**

PLACE THESE INSTRUCTIONS IN THE VEHICLE'S GLOVEBOX AFTER INSTALLATION IS COMPLETED

WARNING:

1. Do not, drill, cut, weld or otherwise modify the tow bar.
2. If you are using electric welding on a motor vehicle, **always** check that the vehicle is not equipped with electronic engine or instrument management equipment. Failure to do so could **destroy** any onboard computers. If in doubt, check with the vehicle's manufacturer.
3. The high tensile fasteners supplied with this product were used to achieve the specified rating. If replacement is required ensure that fasteners of the same rating & quality are used. Contact an authorised **Trailboss** dealer if further information is required.

General:

1. Ensure all hardware items have been included refer to assembly diagram.
2. It is recommended that the instructions are read through and completely understood before making any attempt to fit this product.
3. Be wary of any changes to vehicle designs or other accessories that may conflict with the installation of this product.
4. Before drilling ensure that the area is clear of fuel, electrical & other components.
5. All holes drilled into the body panels shall have all burrs & swarf removed then coated with a suitable rust preventative paint.
6. For vehicles that require the bumper to be cut. Ensure cut out area is in correct position on the vehicle prior to cutting the bumper.
7. The high tensile fasteners supplied with this product were used to achieve the specified rating. If replacement is required ensure that fasteners of the same rating & quality are used. Contact an authorized **Trailboss** dealer if further information is required.
8. Ensure that all hardware is fastened to torque list below check fasteners on regular basis.
9. Tow bar load rating sticker provided with this product shall be conspicuously located on inside rear end of the driver's door. **(See diagram below).**
10. Trailboss recommends that you check your tow ball to ensure that it complies with the Australian standards **AS 4177.2.**
11. **PLEASE NOTE:** It is advised to remove your lug or tbm when not actually towing so as to produce a clear view of the vehicles registration plate if obscured, and to also provide maximum available departure angle
12. Pull Pin must be fit in down position.

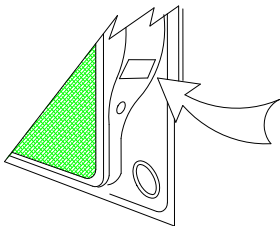

Place load rating sticker
inside driver's door here

FOR TRAILER TOWING PURPOSES ONLY
For towing capacity details please refer to vehicle owner's manual or to the manufacturer. Overloading can void your warranties.

RECOMMENDED ASSEMBLY TORQUE LISTING

<u>Diameter</u>	<u>Grade 8.8 Bolt</u>
M6	9.5 Nm
M8	21.7 Nm
M10	43.4 Nm
M12	77.3Nm
M14	146 Nm
M16	189.8 Nm

Tow bar Maintenance and Care.

Trailboss recommends that bolt torque's, as listed below, are routinely and regularly inspected and checked for correct tension. Replace any worn or defective parts.

We recommended to remove Tow Ball Mounts (TBM's, tongues or lugs) when not being used for any considerable length of time.

So as to avoid injury, when not towing it is suggested that the tongue, Pull Pin and R-clip are removed then stored in a safe, clean and dry place, away from excessive moisture.

Hitch Pull Pins and spring "R" clips are regularly checked for proper installation. Replace any worn or defective parts.

TRAILBOSS

Towbar Fitting Instructions
 To Suit **FORD TRANSIT VAN SERIES 11/2000-02/2014**
 Part Number **QTFD1919L**
 Rating **3000/300 kg**

PLACE THESE INSTRUCTIONS IN THE VEHICLE'S GLOVEBOX AFTER INSTALLATION IS COMPLETED

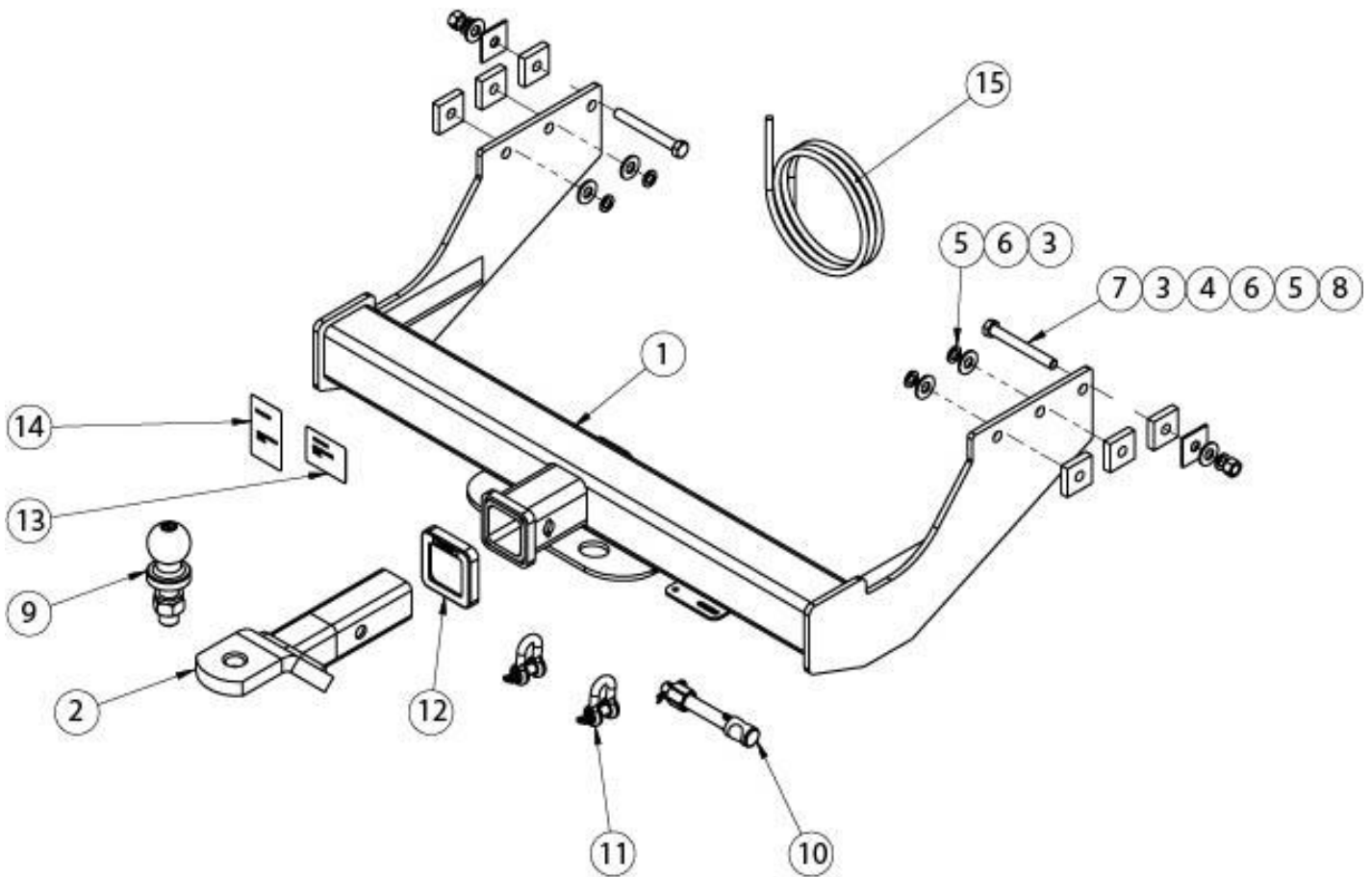

ITEM	DESCRIPTION	QTY
1	WELDED ASSEMBLY	1
2	TRAILER BALL MOUNT	1
3	LOOSE PLATE	6
4	LOOSE PLATE	2
5	WASHER SPRING M12x4.0x2.5	6
6	WASHER FLAT M12	6
7	BOLT HEX HD M12x100x1.75P	2
8	NUT HEX HD M12x1.75P	2
9	TOWBALL 50mm	1
10	SMART PIN SILVER	1
11	"D" SHACKLE 10mm	2
12	HITCH BOX COLLAR COVER	1
13	COMPLIANCE LABEL	1
14	LOAD RATING LABEL	1
15	WIRING LOOM	1



Towbar Fitting Instructions
To Suit **FORD TRANSIT VAN SERIES 11/2000-02/2014**
Part Number **QTFD1919L**
Rating **3000/300 kg**

PLACE THESE INSTRUCTIONS IN THE VEHICLE'S GLOVEBOX AFTER INSTALLATION IS COMPLETED

INSTRUCTION:

1. Lower the Spare Wheel.
2. Remove four Bumper iron Bolts.
3. Lift Towbar up into position, aligning most rearward holes in Towbar side arms with most rearward holes of Chassis and refit four Bumper iron Bolts, with Packers in between the rails and the Towbar.
4. Loosely fit Nuts and Spring Washers to Bumper iron Bolts.
5. Fit two M12 x 100 Bolt, Spring Washer, Nut and (packer) loose plates in between Chassis and Towbar Side Arms, to most forward holes loosely.
6. Tighten bolts to torque listed in Page 1.
7. Refit the spare wheel.



Wiring Loom Fitting Instructions
To Suit Ford Transit Van, Ford Transit Custom Van VN
Part Number 100053-WL

Wiring Loom Installation Instructions

Ford Transit Van, Ford Transit Custom Van VN
Part No: 100053-WL

ECU Required Part No: 04829
Tail Length Required: 1200mm

RPA Over-ride Switch Part No: 04848
(If fitted and only applicable to Transit Van models.
Transit Custom models can disable RPA via dash switch)

Wiring Loom Installation Time: Approx 20 Mins



Wiring Loom Fitting Instructions
To Suit Ford Transit Van, Ford Transit Custom Van VN
Part Number 100053-WL

For Transit Custom Vans start on Page 4, otherwise for Ford Transit Vans, continue:

1. Inside the cargo area, remove the RHS tail light fasteners.
2. Dislodge the RHS tail light
3. Repeat steps for LHS.
4. Disconnect the RHS tail light connector from the RHS tail light assembly.
5. Repeat step for LHS.
6. From underneath the rear quarters of the vehicle remove the LHS & RHS grommets.
7. In the RHS tail light cavity, using the supplied ezy tap and following the table below connect the vehicle red power wire then connect the trailer harness (P:No 100053-WL) terminal to the corresponding wire.

Function	Trailer Patch	Vehicle Wire
12v POWER	RED	ORANGE

8. In the RHS tail light cavity, following the table below, connect the ezy taps to the vehicle tail light connector wire and then connect the trailer harness terminals to the corresponding wires.

Function	Trailer Patch	Vehicle Wire
R.IND	GREEN / BLACK	GREEN / RED
REVERSE	BLACK / WHITE	GREEN / BLACK
TAILS	BROWN / BLACK	YELLOW / BLACK
BRAKES	RED / BLACK	PURPLE / WHITE

9. In the RHS tail light cavity connect the trailer harness ground ring terminal to the vehicle grounding point. **Note: If no grounding points available, tek screw (not supplied) to a suitable grounding location on the vehicle sheet metal area.**
10. Route the trailer harness down through the RHS tail light cavity and out the vehicle grommet hole.
11. Route the trailer harness across rear of the vehicle towards the LHS and up through the LHS tail light cavity.
12. Ensure the trailer harness grommets are seated correctly and secured in place using cable ties (not supplied).



Wiring Loom Fitting Instructions
To Suit Ford Transit Van, Ford Transit Custom Van VN
Part Number 100053-WL

13. Following the table below, connect the ezy tap to the vehicle tail light connector wire then connect the trailer harness terminal to the corresponding wire.

Function	Trailer Patch	Vehicle Wire
L.IND	GREY / RED	YELLOW / BLACK

14. Mount the tail harness (tail length 1200mm) socket to the towbar mounting bracket using M4 fasteners (not supplied).

15. Route the tail harness underneath the rear bumper fascia, along the towbar towards the RHS. Secure with cable ties (not supplied).

16. Waterproof the trailer harness 8-way female connector and the tail harness 8-way male connector using silicone or electrical grease.

17. Connect the trailer harness 8-way female connector to the tail harness 8-way male connector. **Note: Seal the grommet with the silicone and tape.**

18. Connect the trailer harness 12-way connector to the ECU. Apply double sided tape to the ECU and adhere to the area just below the RHS tail light cavity.

Note: Ensure the ECU connector is facing downwards. Ensure the vehicle sheet metal is cleaned using the supplied alcohol wipes before mounting ECU.

19. Test the Trailer socket using a light board or multi-meter.

20. Secure all harnesses using cables ties (not supplied).

21. Refit all removed parts and secure all fasteners.

22. Place instructions in glove box after fitment.



Wiring Loom Fitting Instructions
To Suit Ford Transit Van, Ford Transit Custom Van VN
Part Number 100053-WL

The following Steps for Transit Custom Vans only:

1. Inside the cargo area, remove the rear RHS lower panel by removing all the clips.
2. Underneath the vehicle bumper RHS rear quarter area, locate the two vehicle grommets (round and rectangular). Drill out a Ø30mm hole on the sheet metal in between these two grommets. Apply rust inhibitor after drilling (not supplied).
3. At the RHS side panel cavity, locate the RHS vehicle harness and expose the wires (located below the factory ECU).
4. Following the table below, connect the trailer patch harness (P/No:100053-WL) ezy-taps to the corresponding vehicle wires, then connect the trailer patch terminals to the ezy-taps.

Function	Trailer Patch	Vehicle Connector
R.IND	GREEN / BLACK	GREEN / ORANGE
BRAKES	RED / BLACK	LT. PURPLE / PURPLE
TAILS	BROWN / BLACK	WHITE / ORANGE
REVERSE	BLACK / WHITE	GREEN / BROWN
12V+	ORANGE	LT. PURPLE / YELLOW

5. Secure the trailer patch ground ring terminal to the vehicle grounding point using the existing vehicle fastener.
6. Connect the trailer harness 12-way connector to the ECU. Apply double sided tape to the ECU and adhere to the RHS cargo hold sheet metal cavity. **Note: Ensure the ECU connector is facing downwards. Ensure the vehicle sheet metal is cleaned using the supplied alcohol wipes before mounting ECU.**
7. Underneath the vehicle, pierce a small hole into the RHS rectangular grommet and route the trailer patch L.IND terminal branch through.
8. Continue to route the trailer patch terminal branch across the rear bumper interior towards the LHS rectangular grommet. **Keep routing clear of any moving parts, sharp objects or areas of extreme heat.**
9. Following the table below, connect the trailer patch harness L.IND wire ezy-tap to the corresponding vehicle wire and then connect the trailer patch terminal to the ezy-tap.

Function	Trailer Patch	Vehicle Connector
L.IND	YELLOW / BLACK	GREY / RED

10. Seal the pierced grommets with silicone.
11. At the rear exterior of the vehicle, mount the tail harness socket to the towbar mounting bracket using M4 fasteners (not supplied).
12. Route the tail harness (tail length: 1200mm) across the RHS and up into the drilled out hole. Adjust the trailer patch harness grommet so that it is seated correctly and cable tie (not supplied) in place.



Wiring Loom Fitting Instructions
To Suit Ford Transit Van, Ford Transit Custom Van VN
Part Number 100053-WL

13. Connect the tail harness 8-way connector to the trailer patch 8-way mating connector.
14. Test the Trailer socket using a light board or multi-meter.
15. Secure all harnesses using cables ties (not supplied).
16. Refit all removed parts and secure all fasteners.
17. Place instructions in glove box after fitment.
18. RPA function can be disabled via the RPA switch on the dash.



FITTING INSTRUCTIONS

Silent Anti-Rattle Hitch Pin (PR0001)

• These fitting instructions are supplied to ensure understanding of how the HITCH PIN should be fitted and used correctly.

• Once installed, we recommend **ALL** instructions are kept and placed in the vehicle glove box.

NOTE: Routine maintenance and inspection of the towbar & HITCH PIN is required. Regularly inspect for wear and check the tightness of the Hitch Pin. Follow instructions below to retighten the nut when necessary.

***Do not tow with your vehicle if the R CLIP or the HITCH PIN is loose or missing. Replacement parts are available from your Pro Series Distributor.**

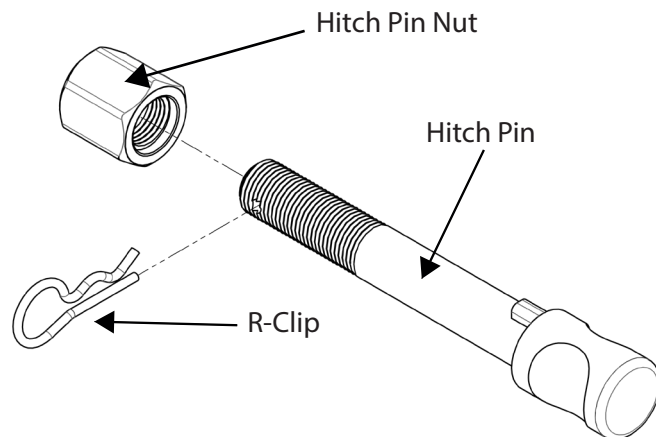

Fig 1. Silent Anti-Rattle Hitch Pin assembly

STEP 1

Insert Trailer Ball Mount (TBM) into towbar HITCHBOX, aligning hole in TBM SHANK with hole in HITCHBOX (Fig 2).

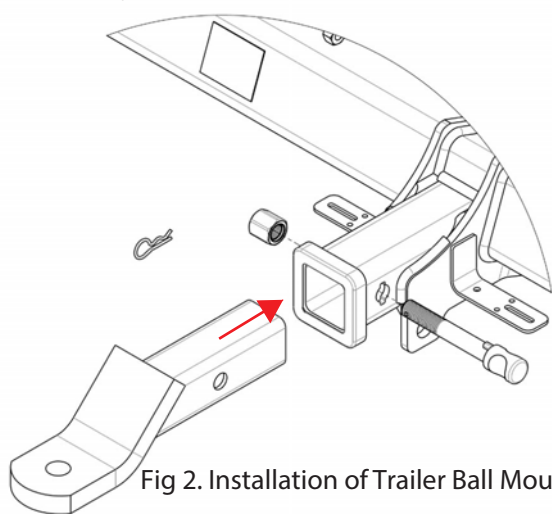

Fig 2. Installation of Trailer Ball Mount

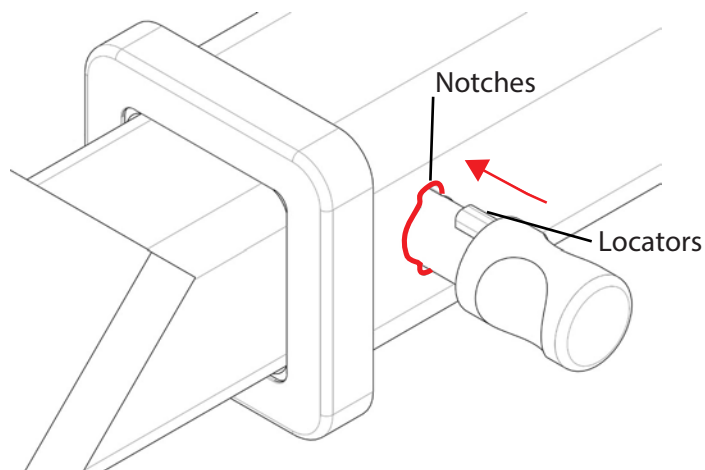

Fig 3. Silent Anti-Rattle Hitch Pin orientation

STEP 2

Insert HITCH PIN through hole in HITCHBOX and hole in TBM SHANK; ensure the LOCATORS are inserted into the NOTCHES in the HITCHBOX (Fig. 3).

STEP 3

Screw HITCH PIN NUT onto HITCH PIN ; tighten HITCH PIN NUT until finger tight, ensuring TBM is restrained from movement.

STEP 4

Tighten HITCH PIN NUT by turning nut a further 1/8th of a turn in the clockwise direction using a 24mm spanner (Fig. 4).

STEP 5

Install HITCH PIN R CLIP through the hole on the HITCH PIN (Fig. 1).

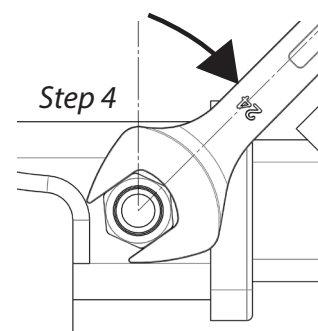

Fig 4. Tightening of Silent Anti-Rattle Hitch Pin Nut