



TOWBAR INSTALLATION INSTRUCTIONS

PART NUMBER QTFD1920L

FORD RANGER CL4 UTE MY22

PRODUCT DETAILS:

Part Number:	QTFD1920L	Maximum Towing Braked:	3500	kg
ECU Number:	WLE70003	Maximum Towing Unbraked:	750	kg
Tail Harness Length Required:	1200 mm	Maximum Static Ball Load:	350	kg
TBM/Lug Part Number:	21161			

FITTING DETAILS:

Towbar Installation Time:	60 Mins.	RPA Disable/Other:	NO
Total Installation Time:	90 Mins.		
Bumper Cut Required:	Yes		

TRAILBOSS RECOMMENDS THAT INSTRUCTIONS ARE READ AND UNDERSTOOD COMPLETELY PRIOR TO FITMENT.

BEFORE YOU START:

Check all hardware items have been included refer to assembly diagram.
Please ensure this towbar is only fitted to vehicle models as per Trailboss application guide.

Bumper Cuts

Vehicle and bumper variations can and do occur during vehicle manufacture after initial towbar design. Fitment of towbar to vehicle and accuracy of bumper cut must be assessed prior to any bumper modifications made. Incorrect bumper cuts are not covered under Trailboss warranty.

NOTE: Bumper cuts need to be approached with care, refer to notes below.

- Bumper centreline – where the centreline of the bumper needs to be determined, the installer must assess centre point by measurement of bumper width or determining two symmetrical reference points to give centreline.
- Bumper edge – To assist with accurate bumper cut measurement, reference to the start of the bumper edge is now being commonly used.
 - Measure from bottom edge along bumper and around corner to the 70 mm point (Figure 1).
 - Do not measure from visible bumper front of corner, upwards (Figure 2).

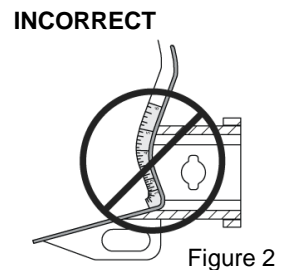
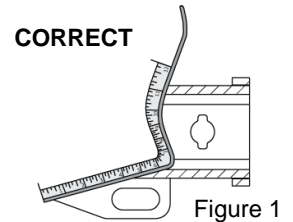

Drilling

- For any required drilling during installation, ensure that the area is clear of fuel, electrical & other components that may be damaged.
- All holes drilled into metal body panels shall have all burrs & swarf removed then coated with a suitable rust preventative paint.

Bolts/Fasteners

- Ensure that all hardware is fastened to correct torque as specified in this fitting instruction.
- All fasteners supplied with this product are used to achieve a specified clamp loading. If replacement is required ensure that fasteners of the same grade and class are used.

NOTE: Achieving correct torque is critical to proper installation and responsibility of the installer. Towbar failures attributed to tension issues from over tightening or under tightening are not covered by Trailboss warranty.

Product Labels

- a. Towbar load rating sticker provided with this product shall be conspicuously located on inside rear end of the driver's door.

WARNING:

Do not, drill, cut, weld or otherwise modify the towbar.

FOR TOWING PURPOSES ONLY - This towbar is designed and tested by Trailboss to adhere to ADR 62/02 which provides only for the expected load demands of towing.

i TOWBAR ASSEMBLY DIAGRAM

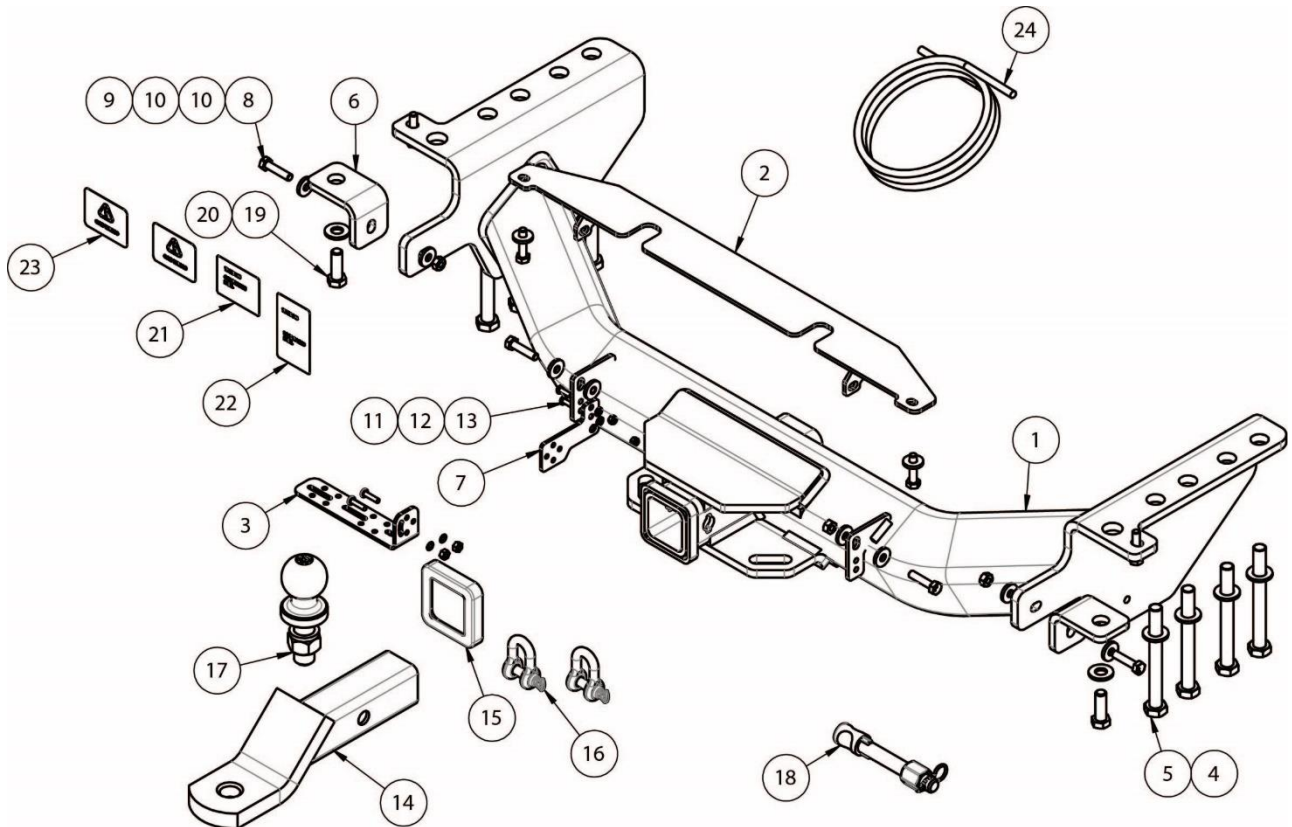

ITEM	DESCRIPTION	QTY
1	FORD RANGER WELDED ASSEMBLY	1
2	STEP WELDED ASSEMBLY	1
3	LARGE UNIVERSAL PLUG BRKT KIT	1
4	WASHER PLAIN M14x28x3.0	8
5	BOLT HEX HD M14x130x2.0P	8
6	BRACKET - STEP	2
7	PLUG BRACKET 2	1
8	BOLT HEX HD M8x35x1.25P	4
9	NUT HEX HD M8x1.25P	4
10	WASHER PLAIN M8x22x3	8
11	NUT NYLOC INS HEX HD M5x0.8P	2
12	WASHER PLAIN M5x10x1	2

ITEM	DESCRIPTION	QTY
13	SCREW PAN XR M5x16x0.8P	2
14	TRAILER BALL MOUNT	1
15	HITCH BOX COLLAR COVER	1
16	10mm "D" SHACKLE	2
17	TOWBALL 50mm	1
18	SMART PIN SILVER	1
19	BOLT HEX HD M12x35x1.75P	2
20	WASHER PLAIN 1/2"	2
21	ACRYLIC LOAD RATING LABEL	1
22	LOAD RATING LABEL	2
23	CAN MODULE WARNING LABEL	2
24	WIRING LOOM	1

1. On the LHS of the chassis, locate the vehicle rear step 16-way wiring connector and disconnect.

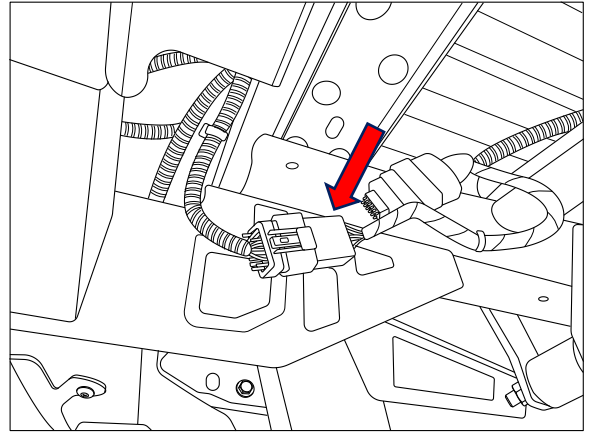

2. On the RHS of the under carriage remove the following fasteners:
2x M8
1x M12

Repeat for the other side.

Pull the rear step and store in a safe place.

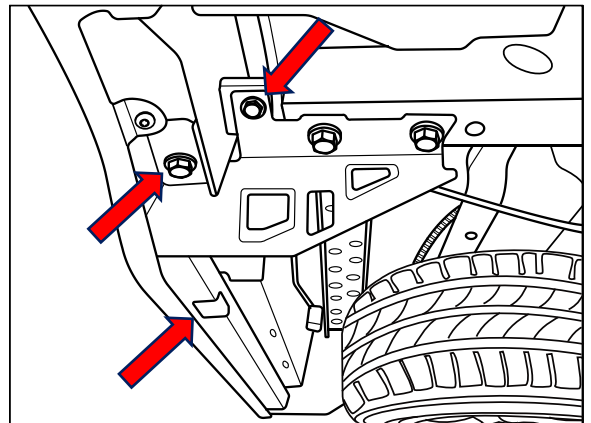

3. Remove 4x M14 bolts that secure the rear step support bracket and discard both bracket and fasteners.

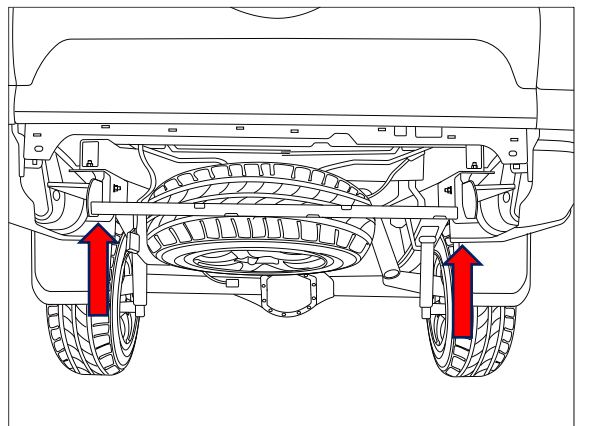

4. Loosely assemble the components to the towbar as shown, using fastener identified on Page 3.

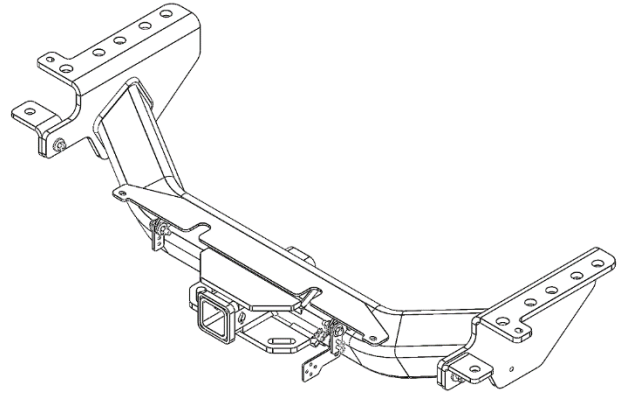

5. Place the tow bar to chassis and loosely secure with 4x M14 bolts and 4x washer

Repeat for the other side

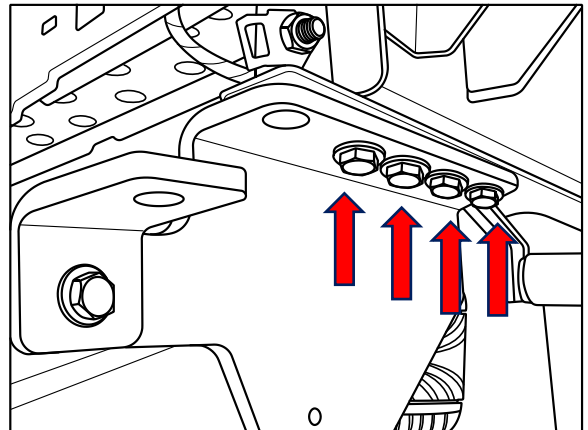

6. Determine the centre light of the garnish, mask of as per image mark a line 20mm down from the feature line.
7. Cut out a section 85mm wide.

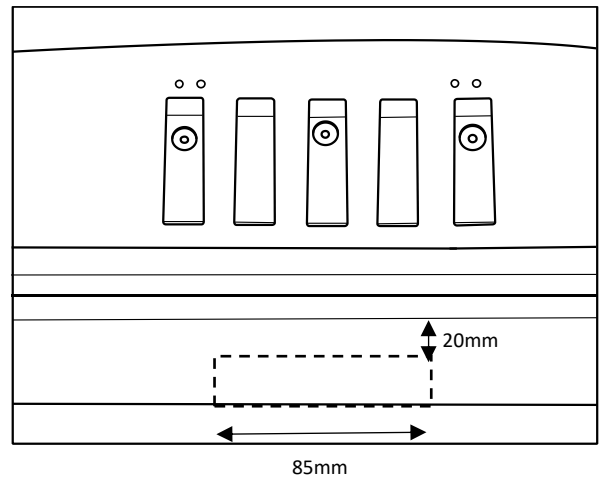

8. Refit the rear step to vehicle align and secure the step brackets M8 and M12 bolts.
9. Reconnect the rear step connector.

Torque fasteners as follows:

M14 x 2.0P = 170 Nm

M12 x 1.75P = 109 Nm

M8 x 1.25P = 22Nm

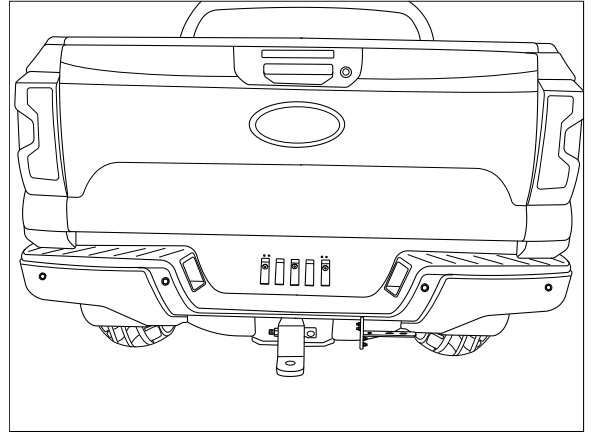

10. On the LHS under carriage, locate and disconnect the blanking connector from the 16-way trailer output Pre-Wire connector.

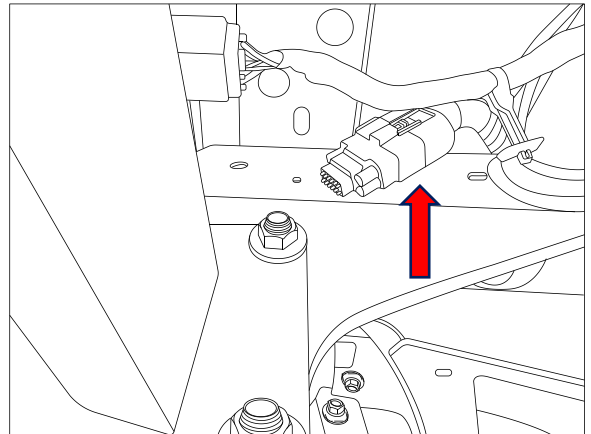

11. Connect the trailer patch (WLL90003) to the vehicle mating connector.
12. Mount the trailer plug to plug bracket, route the tail blue connector towards trailer patch mating connector.
13. **Connect and waterproof the blue connector using electrical grease or silicon.**

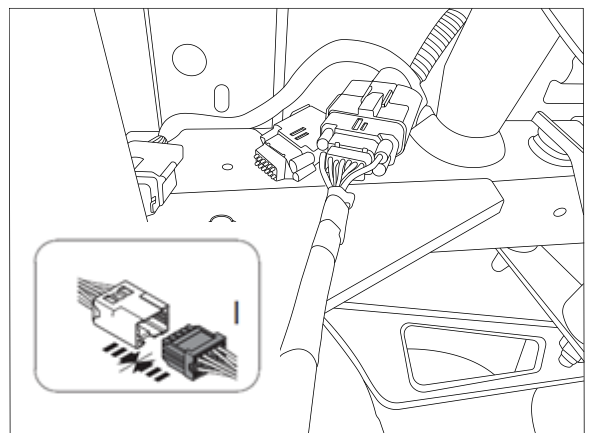

14. From inside the LHS of vehicle remove the following interior trims.

- Dislodge the door seal.
- Remove and detach the glove box. **(When open pull in the side stoppers).**
- Remove the end dash trim.
- Remove the fastener that's secures the front fascia trim, unclip the trim.

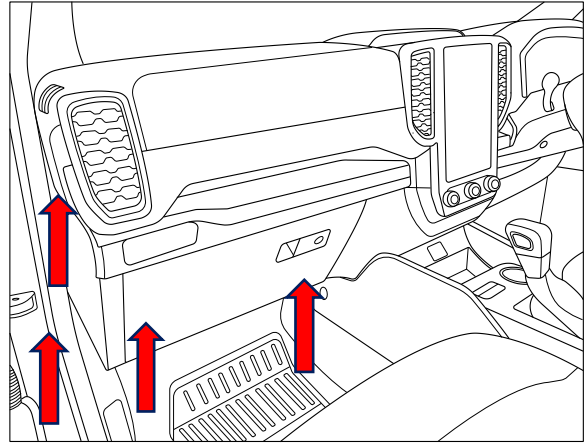

15. Remove the Gateway module 3x fasteners.
16. Move the module enough to gain access the trailer Pre-wire connectors.

Note: Care must be taken when moving the module.

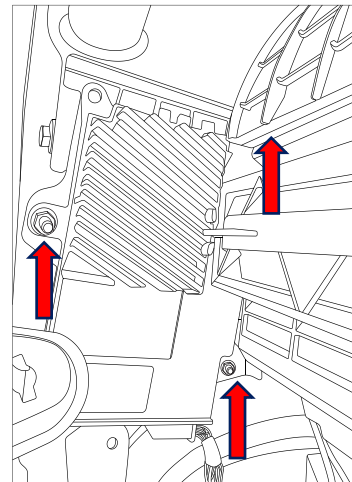

17. Using a flat blade screwdriver release the connector tabs for the 3x trailer prewire connectors.

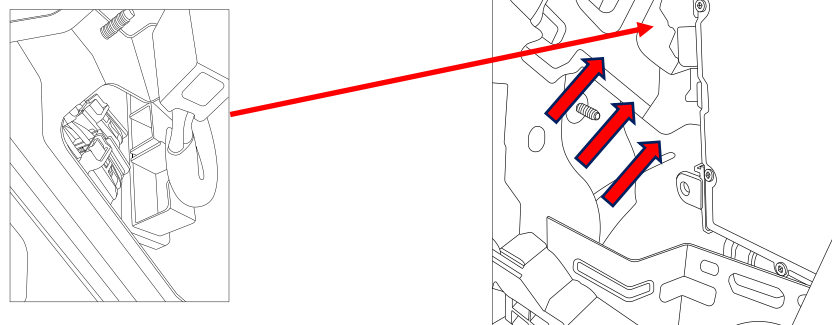

18. From underneath the LHS footwell pull down the released connectors.

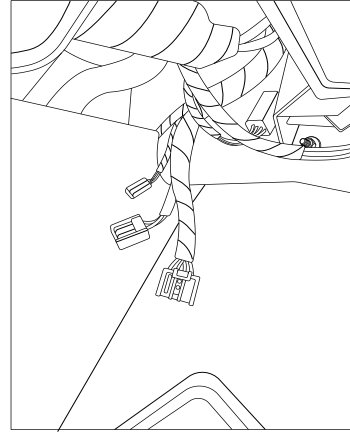

19. Connect the trailer patch (WLL90003) interior harness to mating connectors.

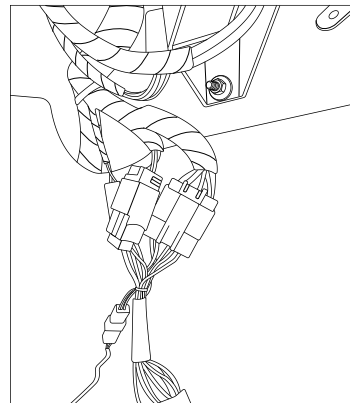

20. Connect the trailer patch connector to the ECU (WLE70003).

21. Attach the supplied Velcro tape to ECU secure the module in behind the LHS footwell.

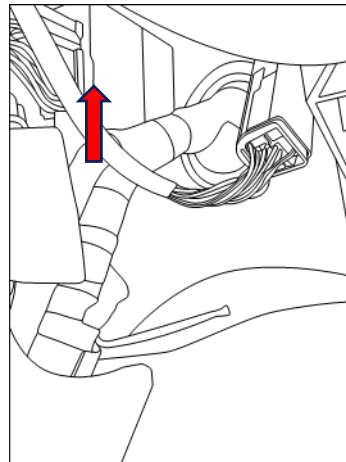

-
22. Refit all removed parts from steps 14-16 in reverse.
 23. Test the functionality of trailer module ensuring all lights work using a trailer test board.
 24. Place fitting instructions in glovebox when finished.
-



CUSTOMER INFORMATION

PLACE THESE INSTRUCTIONS IN THE
VEHICLE'S GLOVEBOX AFTER INSTALLATION

**THANK YOU FOR PURCHASING TRAILBOSS. WITH CORRECT MAINTENANCE AND CARE
THIS PRODUCT WILL PROVIDE A LIFETIME OF TROUBLE-FREE OPERATION.**

TOWBAR MAINTENANCE AND CARE:

1. Trailboss recommend that the towbar LUG or TBM (Trailer Ball Mount) Pull Pin and R-clip are removed and stored when not in use. Removal of LUG or TBM (Trailer Ball Mount) is advisable when not in use to assist with any of the following.
 - Ensure rear number plate is not obscured.
 - Allow maximum available departure angle and prevent any potential interference.
 - Prevent possible interference with vehicles reverse sensors or camera detecting a tow ball mount as an obstruction during reversing.
 - Removes towball mount as an obstruction for when moving around the rear of the vehicle.
2. Trailboss recommends routine inspection of your towbar to ensure trouble free towing.
 - Bolt security and tension should be regularly inspected and checked for correct tension. Replace any worn or defective parts with suitable grade & class fasteners. Inspection should be requested to coincide with vehicle major services.
3. It is the owner's responsibility to ensure towing and down ball weight capacities of the towing vehicle are not exceeded.
 - Towing and down ball weights allowable may differ according to model variations. Please refer to owner's manual or vehicle dealer to confirm exact rating for your vehicle model variant.
 - It is not uncommon for the vehicle tow rating to differ from the towbar rating. When this occurs, the lesser rating must be adhered to.
 - For vehicles fitted with enhanced vehicle functions that may be altered/changed when towing i.e Trailer sway mitigation, blind spot detection, adaptive cruise control etc. Please consult owner's manual to understand changes enabled when towing and after towing.

WARRANTY INFORMATION:

Trailboss Towbars are covered by a Lifetime Warranty.

Our goods come with guarantees that cannot be excluded under the Australian Consumer Law. You are entitled to a replacement or refund for a major failure and for compensation for any other reasonably foreseeable loss or damage. You are also entitled to have the goods repaired or replaced if the goods fail to be of acceptable quality and the failure does not amount to a major failure.

For further details please contact customer service on 1800 812 017.

PRO SERIES SILENT ANTI-RATTLE HITCH PIN

Your Trailboss towbar is equipped with a Pro Series Silent Anti-Rattle Hitch Pin technology to help reduce towbar tongue rattle in most driving conditions. Please ensure below instructions are understood and routine maintenance is carried out to ensure best towing experience.

Regularly inspect for wear and check the tightness of the Silent Anti-Rattle Hitch Pin. Follow instructions below to re-tighten the nut as necessary when movement and noise in the tow ball mount is noted.

- Before towing, ensure R-Clip is properly installed and hitch pin nut is installed and tensioned. Replacement parts are available from your Pro Series Distributor.

TOWBALL MOUNT REMOVAL/INSTALLATION

STEP 1

Insert Trailer Ball Mount (TBM) (a) into towbar hitchbox (b), aligning hole in TBM shank (c) with hole in hitchbox (d) (Fig. 1)

STEP 2

Insert Silent Anti-Rattle Hitch Pin (e) through hole in hitchbox and hole in TBM shank (g); ensure the locators are inserted into the notches in the hitchbox (Fig. 2)

STEP 3

Screw Silent Anti-Rattle Hitch Pin Nut (f) onto Smart Pin (g); tighten Smart Pin Nut until finger tight, ensuring TBM is restrained from up and down movement.

STEP 4

Tighten Silent Anti-Rattle Hitch Pin Nut by turning nut a further 1/8th of a turn in the clockwise direction using a 24mm spanner (Fig. 4).

STEP 5

Install Silent Anti-Rattle Hitch Pin R-Clip through the hole that provides best clearance or easiest access. (Fig. 5)

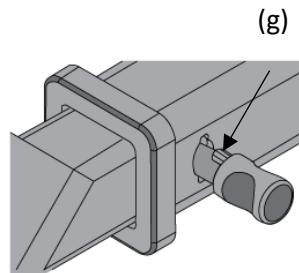
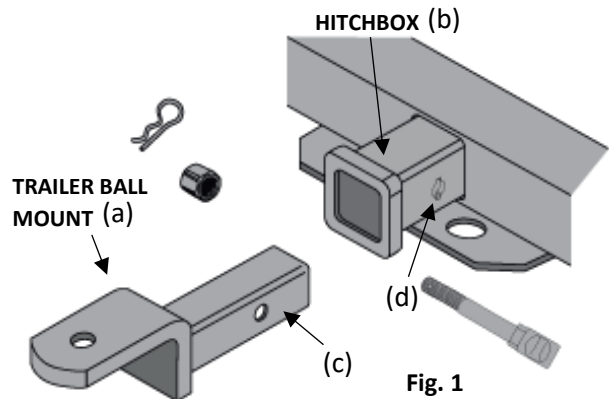

Fig. 2

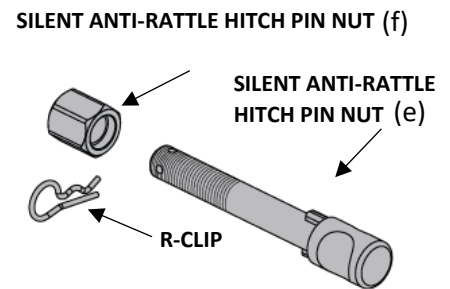

Fig. 3

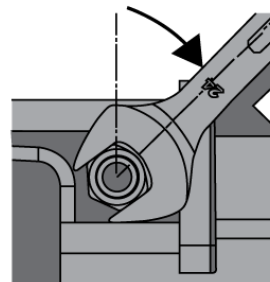

Fig. 4

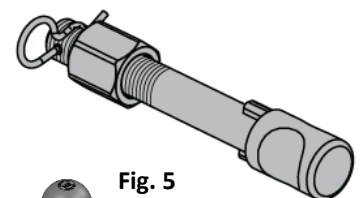

Fig. 5

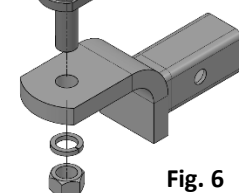

Fig. 6