



Towbar Fitting Instructions
To Suit Ford BA & BF XR6/8 Sedan 10/02-on
Part Number QTFD996L
Rating 2300kg

WARNING:

1. Do not, drill, cut, weld or otherwise modify the tow bar.
2. If you are using electric welding on a motor vehicle, **always** check that the vehicle is not equipped with electronic engine or instrument management equipment. Failure to do so could **destroy** any onboard computers. If in doubt, check with the vehicle's manufacturer.

1. Ensure all hardware items have been included
2. Remove bumper via.
 - (a) Remove 3 plastic trim buttons and 1 self-taping screw from each wheel arch.
 - (b) Remove 3 plastic trim buttons from spear wheel well.
 - (c) Remove plastic trim buttons from rear ¼ trim and fold forward.
 - (d) Remove 4 x 5mm nuts from below tail light assemblies.
 - (e) Remove bumper.
3. Remove two rear most pop rivets from heat shield to gain access to side of sub frame.
4. Cut rear panel & impact beam as per Figs 1 & 3 and coat with anti rust paint.
5. Mark then drill driver side chassis rail as per fig 2 with 11mm drill bit.
6. Temporarily fit tow bar using one taptite bolt per side.
7. Mark and drill 11mm hole forward end of slot on passenger side arm.
8. Mark and drill 11mm hole for vertical holes in cross tube on passenger side.
9. Mark and drill two horizontal 12.5mm holes through driver side arm.
10. Using loose plate with Ø14 holes align with holes drilled in step 5 & 7 and hold in place with masking tape or similar making sure that passenger side loose plate is between side arm & sub frame.
11. Fit remaining bolts, nuts flat & spring washers with bolt on chassis plate to the inside of the chassis rail then tighten to torque listing below.
12. Refit bumper in reverse of step 2 E to A.
13. Refit exhaust heat shield with pop rivets supplied.
14. Note electrical trailer plug to be mounted on under side of bumper or a hang out of boot type.
- 15.

RECOMMENDED ASSEMBLY TORQUE LISTING

Diameter Grade 8.8 Bolt

	Nm;
M6	9.5
M8	21.7
M10	43.4
M12	77.3
M16	189.8

FOR TOWING PURPOSES ONLY
For towing capacity details please refer to vehicle owner's manual or to the manufacturer. Overloading can void your warranties.

TRAILBOSS

Towbar Fitting Instructions
 To Suit Ford BA & BF XR6/8 Sedan 10/02-on
 Part Number QTFD996L
 Rating 2300kg

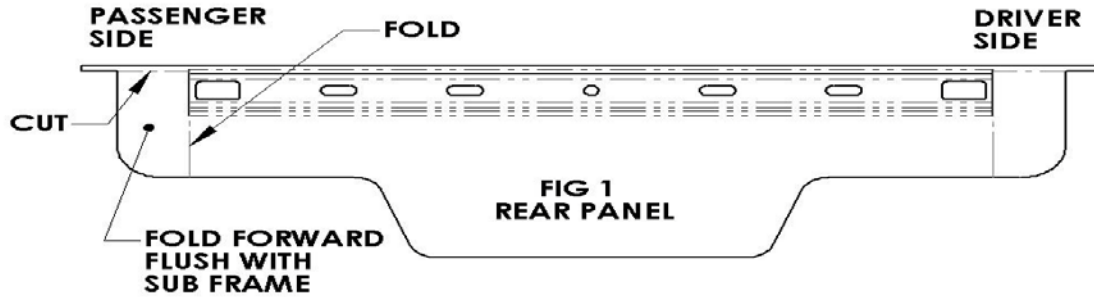

Fig 2

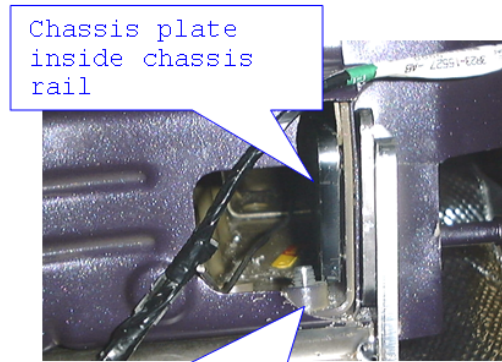
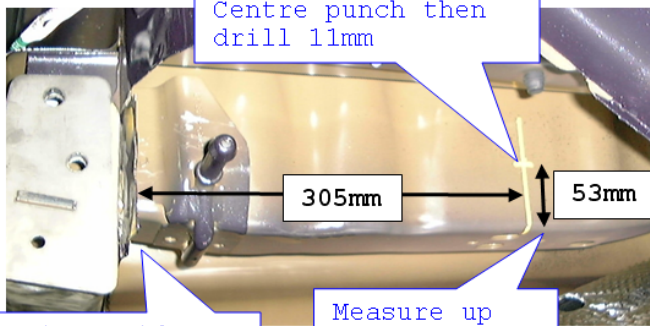
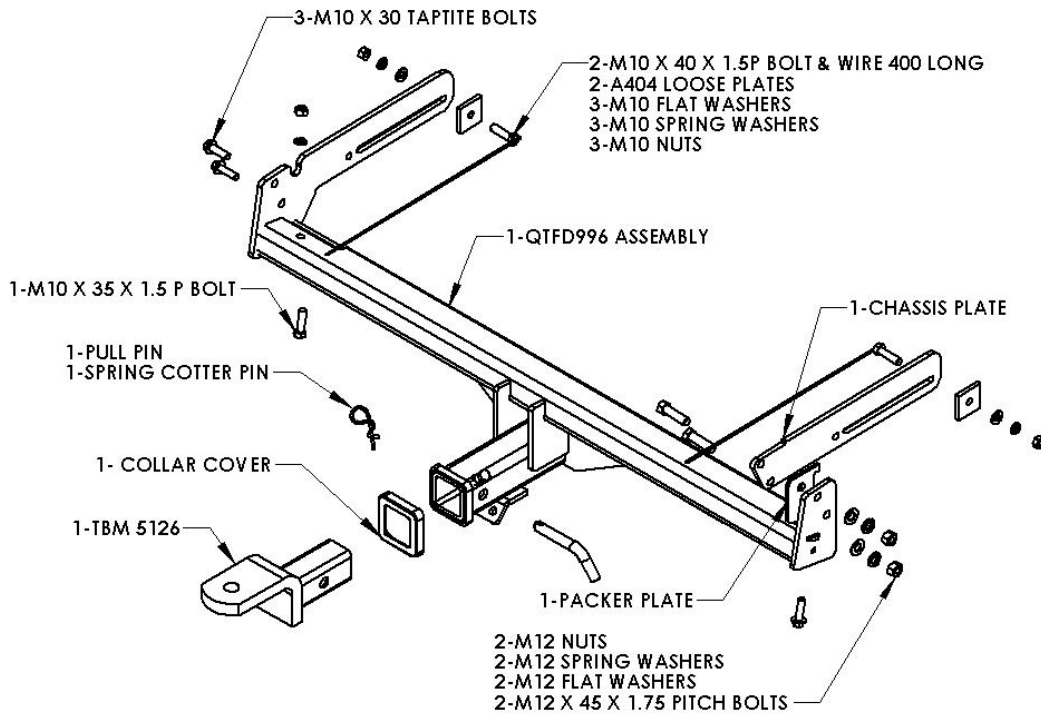

Fig 3

Cut rear panel on driver side only as shown top & bottom to allow chassis plate to fit inside & up chassis rail





Wiring Loom Fitting Instructions
To Suit Ford
BA/BF Falcon Sedan
Wagon AU123 BA (Sept onwards)
Falcon AU Sedan (Sept 1998 to Aug 2002)
BA/BF/XR6/Xr8 Sedan
AU Falcon Sedan (Sept 1998 to Sept 2002)
Part Number 100001-WL

Wiring Loom Installation Instructions

Ford
Part No: 100001-WL

Tail Harness Length Required: 1200mm
RPA Override Switch Part No: 04848 (If Fitted)

Wiring Loom Installation Time: Approx 10 - 40 Mins depending on
vehicle model.



Wiring Loom Fitting Instructions
To Suit Ford
BA/BF Falcon Sedan
Wagon AU123 BA (Sept onwards)
Falcon AU Sedan (Sept 1998 to Aug 2002)
BA/BF/XR6/Xr8 Sedan
AU Falcon Sedan (Sept 1998 to Sept 2002)
Part Number 100001-WL

Sedan Steps:

1. In the luggage compartment, remove the necessary trims to gain access to the RHS tail lights.
2. Connect the Trailer Patch Harness (P/No: 100001-WL) connector to the vehicle break out connector.

BA/BF Sedan models only:

3. At the RHS rear quarter of the vehicle, remove the vehicle grommet.
4. From outside of the vehicle, route in the Tail Harness (length 1200mm) through the grommet hole and connect it to the Trailer Patch Harness connector. **Note: If vehicle is fitted with an RPA kit, drill a Ø30mm access hole near the existing grommet for Tail Harness routing.**
5. Route the Tail Harness socket towards the towbar mounting bracket.
6. Secure the Tail Harness socket onto the towbar mounting bracket using M4 fasteners.

AU Sedan models only:

7. Locate the RHS grommet near the spare wheel well.
8. Mount the Trailer Socket to the towbar using M4 Fasteners then route the Tail Harness (length 1200mm) over to the grommet hole then feed it into the vehicle.
9. From underneath the vehicle, route the Tail Harness (tail length 1800mm) into the vehicle. Slide the grommet to the desired position and then cable tie inside the vehicle. Press the grommet in place, ensuring a good seal is obtained. Then secure the grommet in place with a cable tie (not supplied).
10. In the luggage compartment, connect the Tail Harness to the Trailer Harness Patch.

Test the Tail Harness socket using a light board or multimeter.

11. Secure all harnesses using cables ties.
12. Refit all removed parts and secure all fasteners ensuring there are no squeaks or rattles.
13. Place instructions in glove box after fitment.

Wagon models only:

14. On the RHS trim remove the Jack Access panel and locate the 8-way trailer breakout connector.
15. Plug the Trailer Harness Patch (P/N 100001-WL) to the 8-way trailer breakout connector.



Wiring Loom Fitting Instructions
To Suit Ford
BA/BF Falcon Sedan
Wagon AU123 BA (Sept onwards)
Falcon AU Sedan (Sept 1998 to Aug 2002)
BA/BF/XR6/Xr8 Sedan
AU Falcon Sedan (Sept 1998 to Sept 2002)
Part Number 100001-WL

16. In the jack access cavity area, remove the grommet blanking plug from the RHS rear quarter.
 17. Outside, at the rear of the vehicle, mount the Trailer Socket to the towbar using M4 fasteners.
 18. From underneath the vehicle, route the Tail Harness (length 1200mm) over to the grommet hole then feed it through the grommet hole and into the vehicle. **Note: The grommet must be moved along the harness to the desired location.**
 19. Press the grommet in place, ensuring a good seal is obtained. Then secure the grommet in place with a cable tie (not supplied).
 20. Inside the vehicle, connect the Tail Harness connector to the trailer patch. Cable Tie back any excess length.
 21. Test the Trailer socket using a light board or multi-meter.
 22. Secure the all harnesses using cables ties.
 23. Refit all removed parts and secure all fasteners.
 24. Place instructions in glove box after fitment.
- Territory models only:**
25. Remove the necessary trims to gain access to the RHS vehicle 8-way break out connector then connect the Trailer Patch harness (P/No: 100001-WL) to the break-out connector.
 26. On the RHS rear, below the tail light, remove the grommet and feed the Tail Harness (Length 1200mm) through the hole until it comes through the inner cavity.
 27. Connect the Trailer Patch Harness to the Tail Harness.
 28. On the outside rear of the vehicle, secure the trailer socket onto towbar mounting plate using M4 fasteners.
 29. Test the Trailer socket using a light board or multi-meter.
 30. Secure the all harnesses using cables ties.
 31. Refit all removed parts and secure all fasteners.
 32. Place instructions in glove box after fitment.