

**PRODUCT DETAILS:**

---

<b>Part Number:</b>	QTGW008L	<b>Maximum Towing Braked:</b>	3000	kg
<b>ECU Number:</b>	04835	<b>Maximum Towing Unbraked:</b>	750	kg
<b>Tail Harness Length Required:</b>	1800 mm.	<b>Maximum Static Ball Load:</b>	300	kg
<b>TBM/Lug Part Number:</b>	21385			

---

**FITTING DETAILS:**

---

<b>Towbar Installation Time:</b>	60 Mins.	<b>RPA Disable/Other:</b>	YES
<b>Total Installation Time:</b>	100 Mins.		
<b>Bumper Cut Required:</b>	No		

---

**Note:**

- Use 04936 to disable RPA where equipped.
- 22mm drill required.

### TRAILBOSS RECOMMENDS THAT INSTRUCTIONS ARE READ AND UNDERSTOOD COMPLETELY PRIOR TO FITMENT.

#### BEFORE YOU START:

Check all hardware items have been included refer to assembly diagram.  
Please ensure this towbar is only fitted to vehicle models as per Trailboss application guide.

#### Bumper Cuts

Vehicle and bumper variations can and do occur during vehicle manufacture after initial towbar design. Fitment of towbar to vehicle and accuracy of bumper cut must be assessed prior to any bumper modifications made. Incorrect bumper cuts are not covered under Trailboss warranty.

**NOTE: Bumper cuts need to be approached with care, refer to notes below.**

- Bumper centreline – where the centreline of the bumper needs to be determined, the installer must assess centre point by measurement of bumper width or determining two symmetrical reference points to give centreline.
- Bumper edge – To assist with accurate bumper cut measurement, reference to the start of the bumper edge is now being commonly used.
  - Measure from bottom edge along bumper and around corner to the 70 mm point (Figure 1).
  - Do not measure from visible bumper front of corner, upwards (Figure 2).

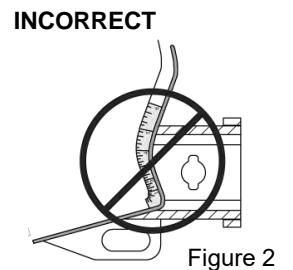
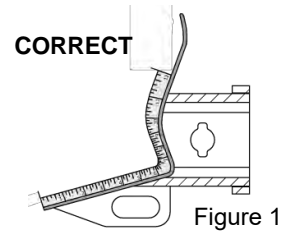

#### Drilling

- For any required drilling during installation, ensure that the area is clear of fuel, electrical & other components that may be damaged.
- All holes drilled into metal body panels shall have all burrs & swarf removed then coated with a suitable rust preventative paint.

#### Bolts/Fasteners

- Ensure that all hardware is fastened to correct torque as specified in this fitting instruction.
- All fasteners supplied with this product are used to achieve a specified clamp loading. If replacement is required ensure that fasteners of the same grade and class are used.

**NOTE: Achieving correct torque is critical to proper installation and responsibility of the installer. Towbar failures attributed to tension issues from over tightening or under tightening are not covered by Trailboss warranty.**

#### Product Labels

- a. Towbar load rating sticker provided with this product shall be conspicuously located on inside rear end of the driver's door.

#### WARNING:

**Do not, drill, cut, weld or otherwise modify the towbar.**

**FOR TOWING PURPOSES ONLY - This towbar is designed and tested by Trailboss to adhere to ADR 62/02 which provides only for the expected load demands of towing.**

### **i** TOWBAR ASSEMBLY DIAGRAM

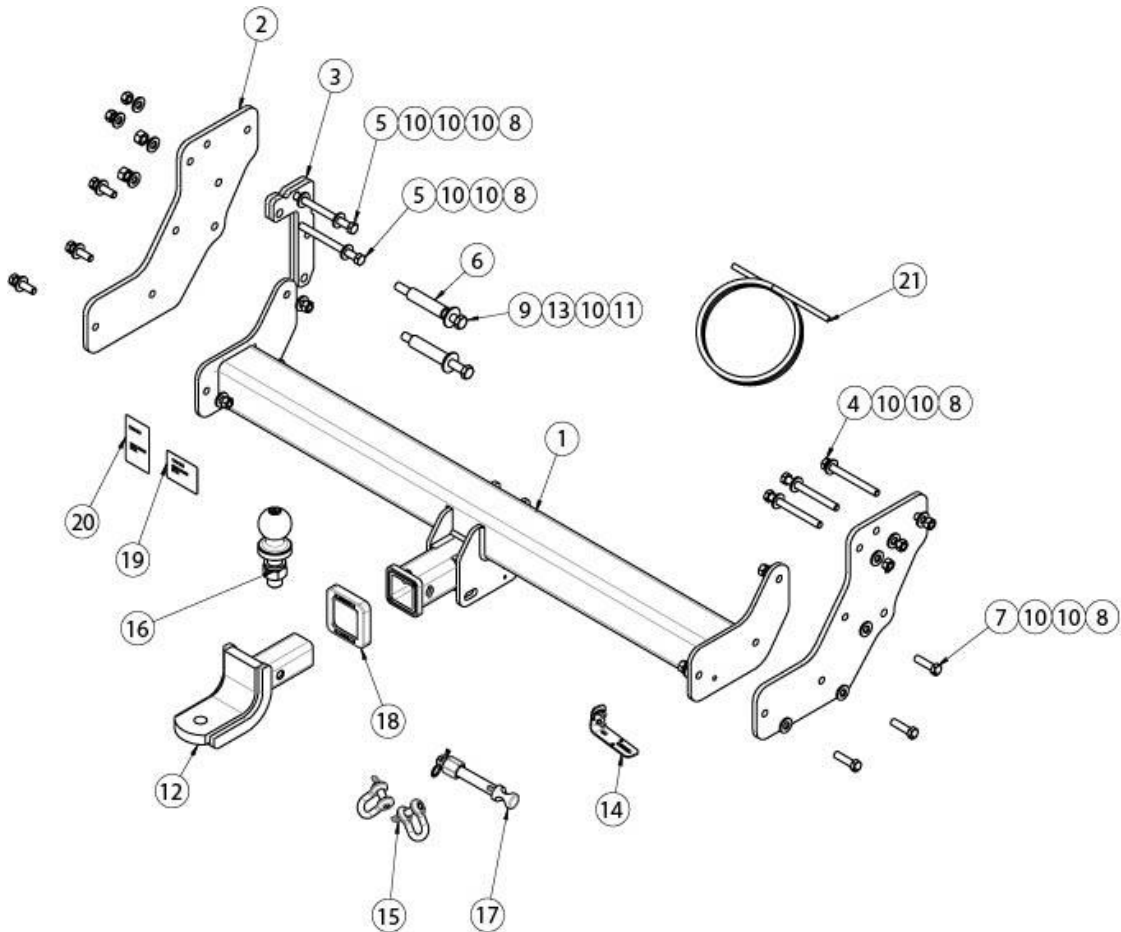

ITEM	DESCRIPTION	QTY
1	GWM CANNON WELD ASSY	1
2	SIDE ARM	2
3	SPACER PLATE	2
4	BOLT HEX HD M12x120x1.25P	3
5	BOLT HEX HD M12x140x1.25P	2
6	CRUSH TUBE	2
7	SET SCREW HEX HD M12x45x1.25P	6
8	NUT HEX HD M12x1.25P	11
9	BOLT HEX HD M14x150x2.0P	2
10	WASHER PLAIN 1/2"	25
11	NUT HEX M14x2.0P	2

ITEM	DESCRIPTION	QTY
12	TRAILER BALL MOUNT	1
13	WASHER PLAIN M12x37x3	2
14	UNIVERSAL PLUG BRACKET KIT	1
15	"D" SHACKLE 10mm	2
16	TOWBALL 50mm	1
17	SMART PIN SILVER	1
18	HITCH BOX COLLAR COVER	1
19	COMPLIANCE LABEL	1
20	DOOR RATING LABEL	1
21	WIRE LOOM	1

1. Lower spare wheel and remove for easier access.

On the LHS chassis rail.

Open 2x the exist hole on the inner face of the recovery hook to Ø22mm then apply primer surfaces.

Remove and discard 2x bolts and 2 x nuts from the chassis.

Note: The bumper will remain bolted in the vehicle throughout the fitment.

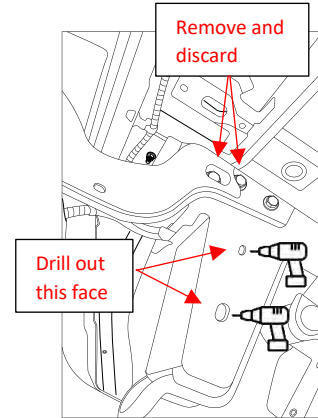

2. On the LHS.  
Fit the 1x washer, 2x spacer and a side arm to the chassis rail. Loosely secure with 2x M12 bolts, 4x washer and 2x nuts.

Insert 2x crush tube in the drilled holes.  
Loosely secure with 2x M14 bolts, 4x washer and 2x nuts.

Note: The larger washers are fitted on the crush tube side.

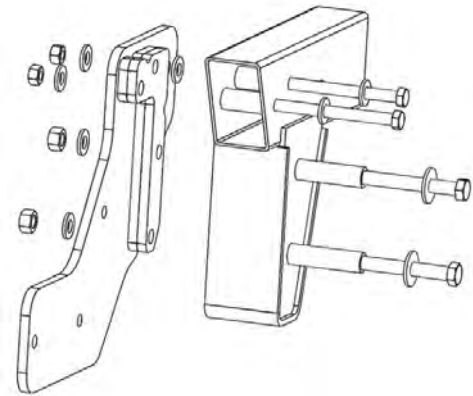

3. On the RHS.  
Remove and discard 3x bolts and 3x Nuts.  
Fit the side arm to the chassis and loosely secure to 3x M12 bolts, 6x washers and 3x nuts.

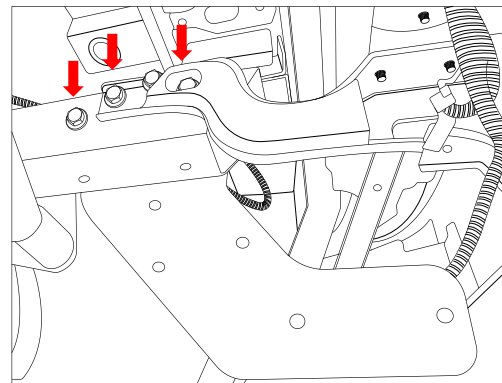

- 
4. Fit the cross tube between the side arms and loosely fit 3x M12 bolts, 6x washers and 3x nuts on each side arm.

Torque fasteners as follows:

M12 x 1.25P = 125 Nm

M14 x 2.0P = 175 Nm

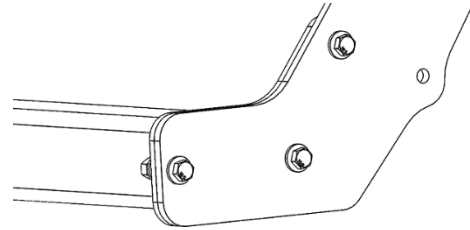

- 
5. Fit plug bracket to the dropper and tighten the 2x screws, 4x washers and 2x nuts.

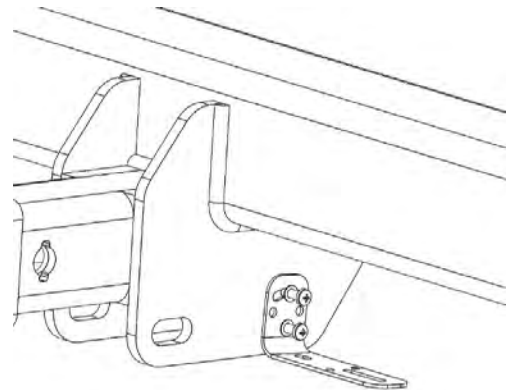

---

### IMPORTANT

Due to possible vehicle variations, always confirm any noted vehicle colour wires with a multi-meter to ensure the correct function is identified before soldering or scotch locking. For vehicle wires denoted with two colours (example; RED/GREEN) the first colour will always be the main wire colour while the second colour is the thinner trace colour on the wire.

- 
6. In the Engine Bay, disconnect the vehicle battery negative terminal.
  7. At the rear of the vehicle, with the rear tray down, remove the two tail lamps (1) by removing the 10mm bolts (2).

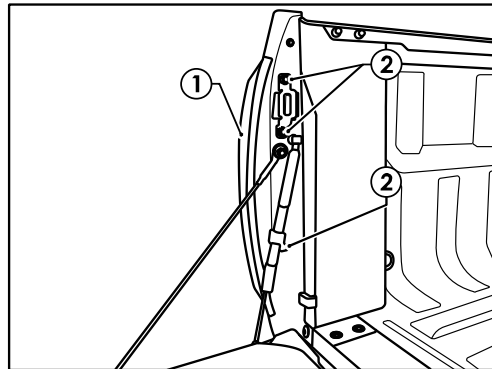

- 
8. From under the vehicle, route the RHS branch on the trailer patch (102643-WL) up into the tail lamp cavity and patch in between the tail lamp (1) and the vehicle wiring (2).
  9. Route the rest of the trailer patch wiring across to the LHS of the vehicle.

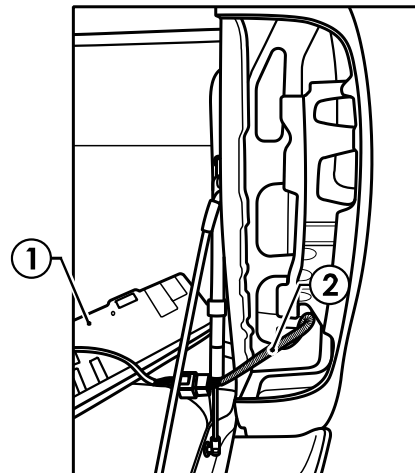

- 
10. From under the vehicle, route the LHS branch up into the tail lamp cavity and patch in between the tail lamp (1) and the vehicle wiring (2).

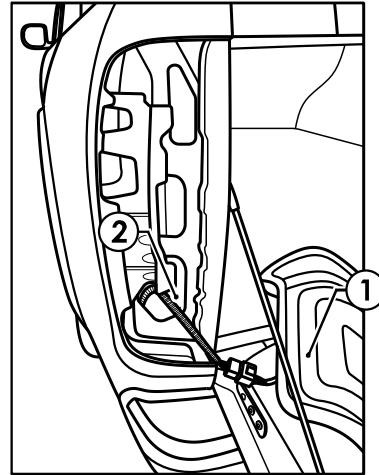

- 
11. Connect the Waterproof ECU (04835) to the trailer patch.  
12. Route the ECU connector branch to above the chassis rail (2) and secure using 2 cable ties.

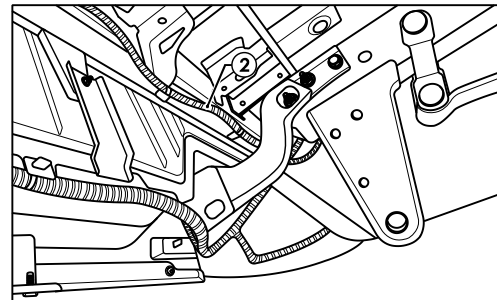

- 
13. Route the orange power wire and white ground wire down the LHS towards the front of the vehicle.

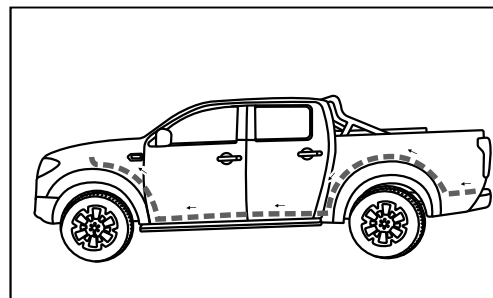

14. Connect the orange wire ring terminal to the vehicle battery positive (1).
15. Connect the white wire ring terminal to the vehicle earthing point (2) near the washer bottle.

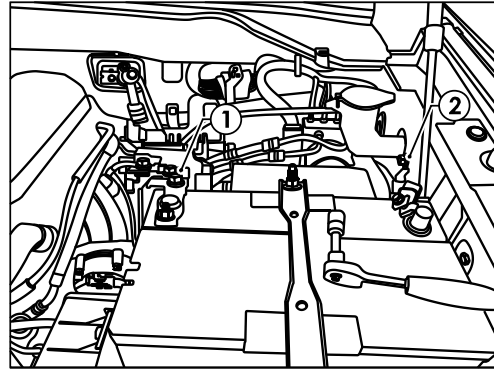

16. Connect the tail harness (tail length 1200mm) 8-way connector (1) to the trailer patch mating 8-way connector (2).
17. Use silicone grease to seal the blue connectors.

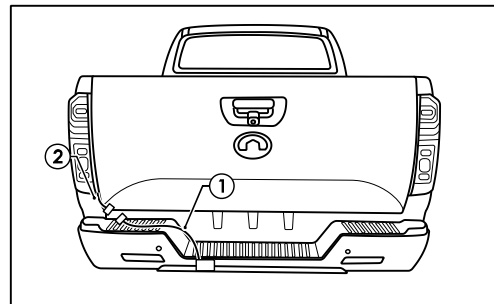

**Note: Keep harness routing clear of all sharp edges, moving parts and places of extreme heat.**

18. For automatic RPA disable use tail harness part number 04936.
19. Cut the Red/Yellow wire (1) at the vehicle bumper connector.
20. Strip, crimp and seal the tail harness GREY and GREY/BLACK wires to either side of the vehicle Red/Yellow wire at the vehicle bumper connector (Pin 1 marked on the connector).
21. Secure all harness using supplied cable ties.
22. Test the trailer patch function using a light board or multi-meter.
23. Re-fit all removed parts and secure all fasteners, ensuring there are no squeaks or rattles.
24. Place the fitting instructions in the glove box after fitment.

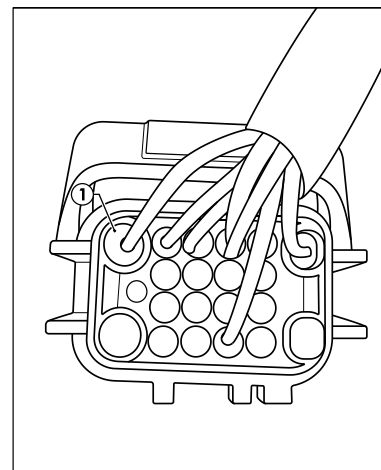





## CUSTOMER INFORMATION

PLACE THESE INSTRUCTIONS IN THE VEHICLE'S GLOVEBOX AFTER INSTALLATION

**THANK YOU FOR PURCHASING TRAILBOSS. WITH CORRECT MAINTENANCE AND CARE THIS PRODUCT WILL PROVIDE A LIFETIME OF TROUBLE-FREE OPERATION.**

### **TOWBAR MAINTENANCE AND CARE:**

1. Trailboss recommend that the towbar LUG or TBM (Trailer Ball Mount) Pull Pin and R-clip are removed and stored when not in use. Removal of LUG or TBM (Trailer Ball Mount) is advisable when not in use to assist with any of the following.
  - Ensure rear number plate is not obscured.
  - Allow maximum available departure angle and prevent any potential interference.
  - Prevent possible interference with vehicles reverse sensors or camera detecting a tow ball mount as an obstruction during reversing.
  - Removes towball mount as an obstruction for when moving around the rear of the vehicle.
2. Trailboss recommends routine inspection of your towbar to ensure trouble free towing.
  - Bolt security and tension should be regularly inspected and checked for correct tension. Replace any worn or defective parts with suitable grade & class fasteners. Inspection should be requested to coincide with vehicle major services.
3. It is the owner's responsibility to ensure towing and down ball weight capacities of the towing vehicle are not exceeded.
  - Towing and down ball weights allowable may differ according to model variations. Please refer to owner's manual or vehicle dealer to confirm exact rating for your vehicle model variant.
  - It is not uncommon for the vehicle tow rating to differ from the towbar rating. When this occurs, the lesser rating must be adhered to.
  - For vehicles fitted with enhanced vehicle functions that may be altered/changed when towing i.e Trailer sway mitigation, blind spot detection, adaptive cruise control etc. Please consult owner's manual to understand changes enabled when towing and after towing.

### **WARRANTY INFORMATION:**

Trailboss Towbars are covered by a Lifetime Warranty.

Our goods come with guarantees that cannot be excluded under the Australian Consumer Law. You are entitled to a replacement or refund for a major failure and for compensation for any other reasonably foreseeable loss or damage. You are also entitled to have the goods repaired or replaced if the goods fail to be of acceptable quality and the failure does not amount to a major failure. For further details please contact customer service on 1800 812 017.

## PRO SERIES SILENT ANTI-RATTLE HITCH PIN

Your Trailboss towbar is equipped with a Pro Series Silent Anti-Rattle Hitch Pin technology to help reduce towbar tongue rattle in most driving conditions. Please ensure below instructions are understood and routine maintenance is carried out to ensure best towing experience.

Regularly inspect for wear and check the tightness of the Silent Anti-Rattle Hitch Pin. Follow instructions below to re-tighten the nut as necessary when movement and noise in the tow ball mount is noted.

- Before towing, ensure R-Clip is properly installed and hitch pin nut is installed and tensioned. Replacement parts are available from your Pro Series Distributor.

## TOWBALL MOUNT REMOVAL/INSTALLATION

### STEP 1

Insert Trailer Ball Mount (TBM) (a) into towbar hitchbox (b), aligning hole in TBM shank (c) with hole in hitchbox (d) (Fig. 1)

### STEP 2

Insert Silent Anti-Rattle Hitch Pin (e) through hole in hitchbox and hole in TBM shank (g); ensure the locators are inserted into the notches in the hitchbox (Fig. 2)

### STEP 3

Screw Silent Anti-Rattle Hitch Pin Nut (f) onto Smart Pin (g); tighten Smart Pin Nut until finger tight, ensuring TBM is restrained from up and down movement.

### STEP 4

Tighten Silent Anti-Rattle Hitch Pin Nut by turning nut a further 1/8th of a turn in the clockwise direction using a 24mm spanner (Fig. 4).

### STEP 5

Install Silent Anti-Rattle Hitch Pin R-Clip through the hole that provides best clearance or easiest access. (Fig. 5)

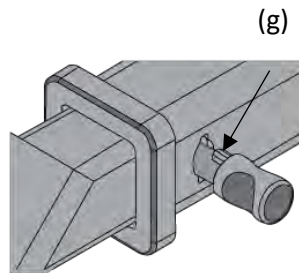
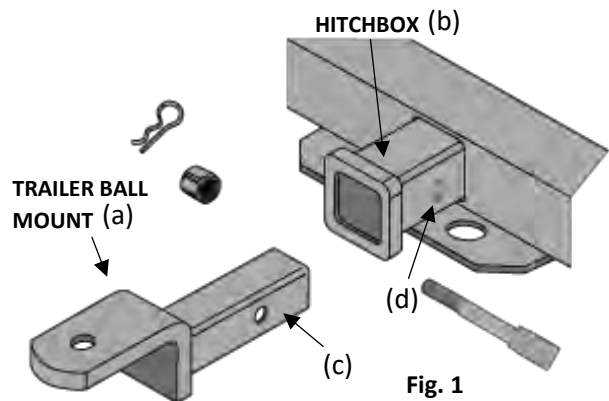

Fig. 2

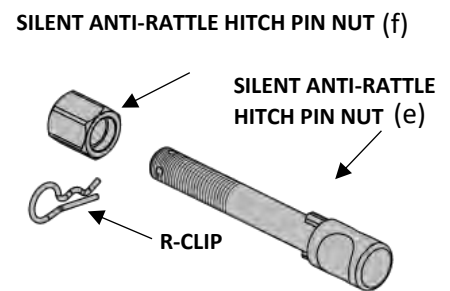

Fig. 3

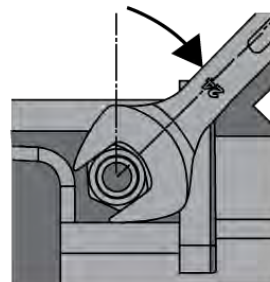

Fig. 4

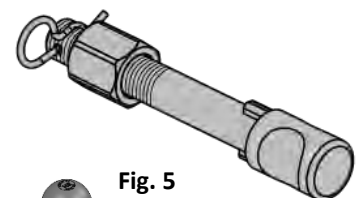

Fig. 5

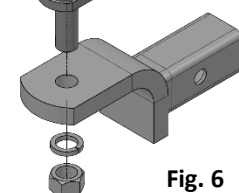

Fig. 6