

PRODUCT DETAILS:

Part Number:	QTHY276L	Maximum Towing Braked:	2500	kg
ECU Number:	04826	Maximum Towing Unbraked:	750	kg
Tail Harness Length Required:	1800 mm	Maximum Static Ball Load:	250	kg
TBM/Lug Part Number:	21161			

FITTING DETAILS:

Towbar Installation Time:	90 Mins.	RPA Disable/Other:	NO
Total Installation Time:	130 Mins.		
Bumper Cut Required:	Yes		

Note:

- RPA disable via switch near transmission lever on vehicle equipped.
- 22 or 7/8 drill bit required for installation.

TRAILBOSS RECOMMENDS THAT INSTRUCTIONS ARE READ AND UNDERSTOOD COMPLETELY PRIOR TO FITMENT.

BEFORE YOU START:

Check all hardware items have been included refer to assembly diagram.
Please ensure this towbar is only fitted to vehicle models as per Trailboss application guide.

Bumper Cuts

Vehicle and bumper variations can and do occur during vehicle manufacture after initial towbar design. Fitment of towbar to vehicle and accuracy of bumper cut must be assessed prior to any bumper modifications made. Incorrect bumper cuts are not covered under Trailboss warranty.

NOTE: Bumper cuts need to be approached with care, refer to notes below.

- Bumper centreline – where the centreline of the bumper needs to be determined, the installer must assess centre point by measurement of bumper width or determining two symmetrical reference points to give centreline.
- Bumper edge – To assist with accurate bumper cut measurement, reference to the start of the bumper edge is now being commonly used.
 - Measure from bottom edge along bumper and around corner to the 70 mm point (Figure 1).
 - Do not measure from visible bumper front of corner, upwards (Figure 2).

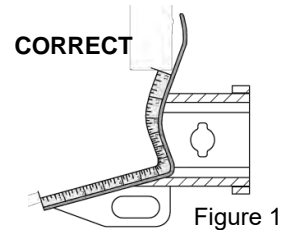

Figure 1

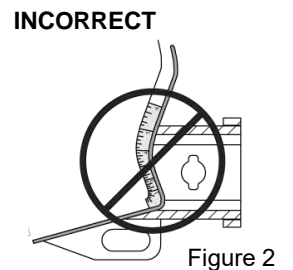

Figure 2

Drilling

- For any required drilling during installation, ensure that the area is clear of fuel, electrical & other components that may be damaged.
- All holes drilled into metal body panels shall have all burrs & swarf removed then coated with a suitable rust preventative paint.

Bolts/Fasteners

- Ensure that all hardware is fastened to correct torque as specified in this fitting instruction.
- All fasteners supplied with this product are used to achieve a specified clamp loading. If replacement is required ensure that fasteners of the same grade and class are used.

NOTE: Achieving correct torque is critical to proper installation and responsibility of the installer. Towbar failures attributed to tension issues from over tightening or under tightening are not covered by Trailboss warranty.

Product Labels

- a. Towbar load rating sticker provided with this product shall be conspicuously located on inside rear end of the driver's door.

WARNING:

Do not, drill, cut, weld or otherwise modify the towbar.

FOR TOWING PURPOSES ONLY - This towbar is designed and tested by Trailboss to adhere to ADR 62/02 which provides only for the expected load demands of towing.

i TOWBAR ASSEMBLY DIAGRAM

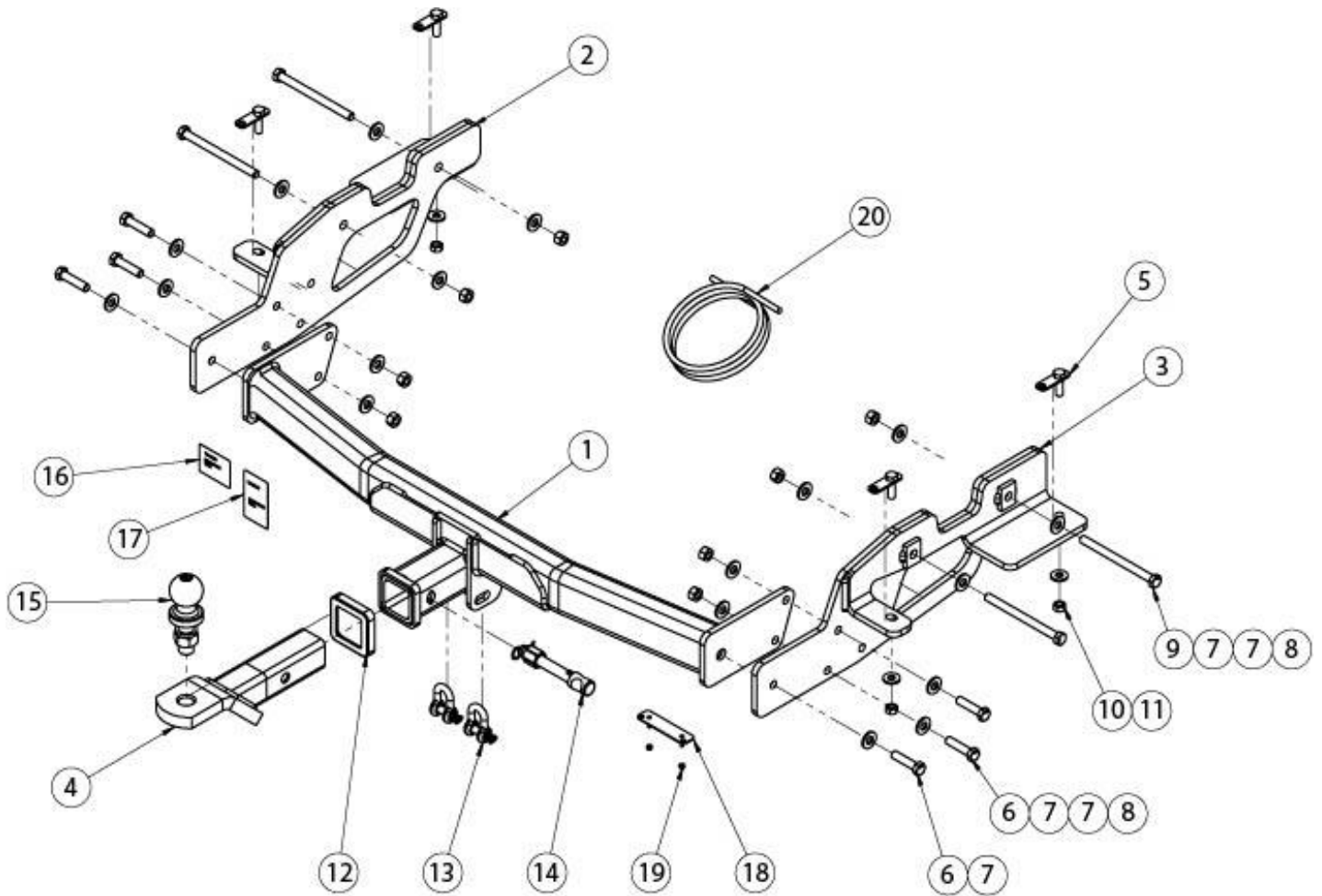

ITEM	DESCRIPTION	QTY
1	HYUNDAI STARIA WELDED ASSEMBLY	1
2	SIDE ARM LHS ASSY	1
3	SIDE ARM RHS ASSY	1
4	TRAILER BALL MOUNT	1
5	T BOLT ASSEMBLY	4
6	BOLT HEX HD M12x50x 1.75P	6
7	WASHER PLAIN 1/2"	18
8	NUT HEX HD M12x1.75P	8
9	BOLT HEX HD M12x150x1.75P	4
10	NUT HEX HD M10x1.5P	4

ITEM	DESCRIPTION	QTY
11	WASHER PLAIN M10x25x3	4
12	HITCH BOX COLLAR COVER	1
13	"D" SHACKLE 10mm	2
14	SMART PIN GOLD	1
15	TOWBALL 50mm	1
16	COMPLIANCE LABEL	1
17	LOAD RATING LABEL	1
18	PLUG BRACKET	1
19	NUT NYLOC HEX HD M4x0.7P	2
20	WIRING LOOM	1

1. Remove 3x Screws from taillight

Repeat for the other side

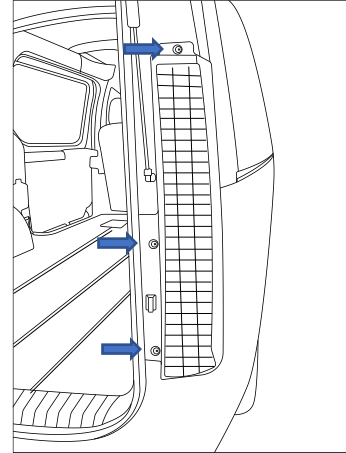

2. Pull the taillight rear ward and disconnect wiring.

Repeat for the other side

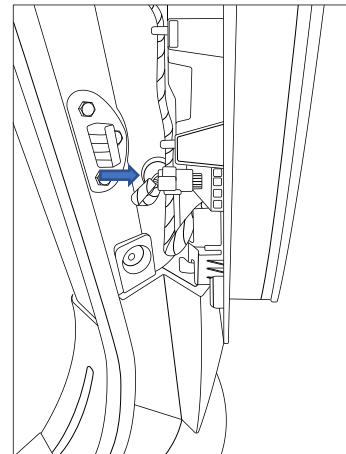

3. Remove 3 x Scrivet Clips connecting the rear bumper.

Repeat for the other side

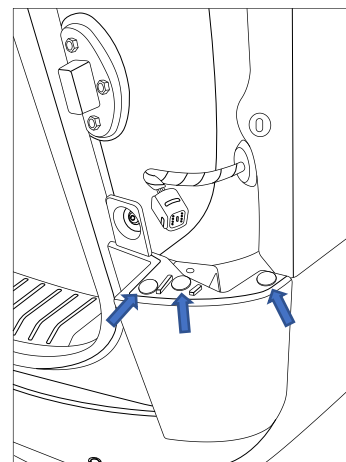

-
4. Remove 1x screws and 2x scrivet clips connecting wheel arch liner to the rear bumper.

Repeat for other side.

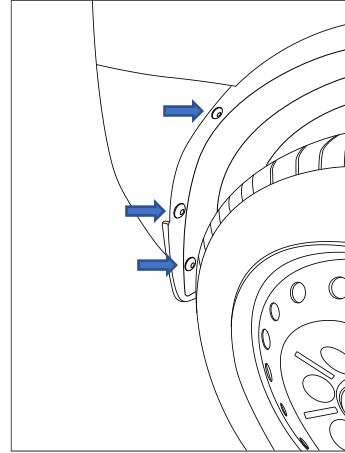

-
5. Remove 3x scrivet clips connecting the connecting wheel arch liner to the rear bumper.

Repeat for other side

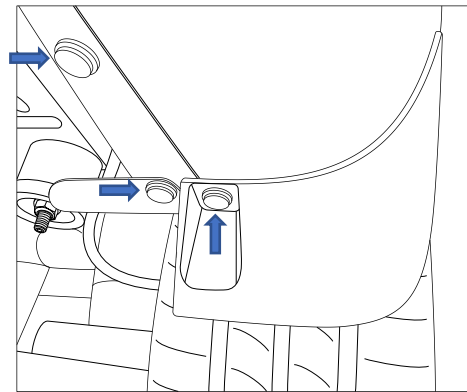

-
6. Remove 2 x Bolts connecting the rear impact beam to the vehicle.

Repeat for other side

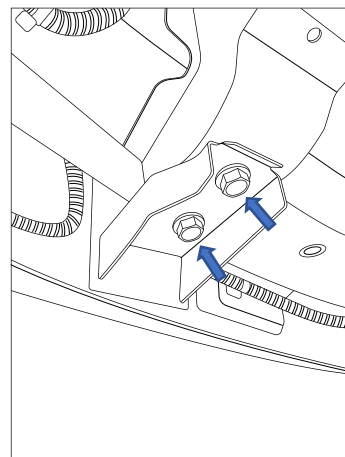

-
7. Disconnect the wiring harness located on the LHS of the rear bumper.

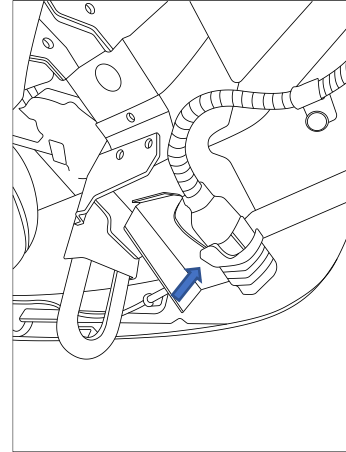

-
8. Unclip the rear bumper.
Repeat for the other side

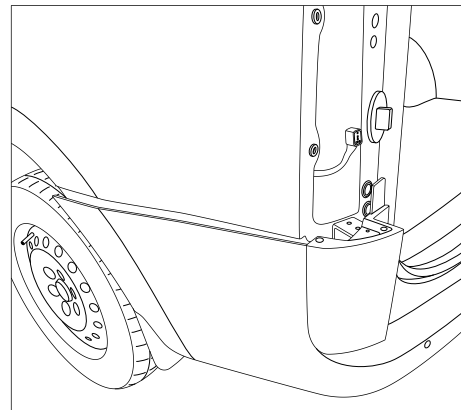

-
9. Remove the rear bumper,
Store safely to avoid damage to the rear bumper.

-
10. Lower the tyre out of the cradle using the factory tool kit and remove the spare wheel from the vehicle.

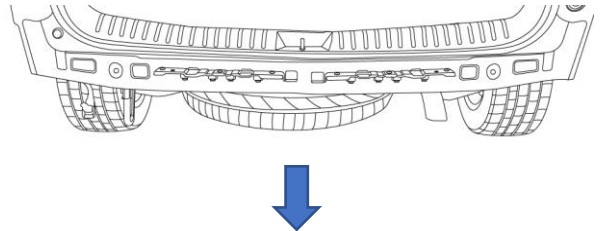

-
11. Remove Exhaust from hanger.

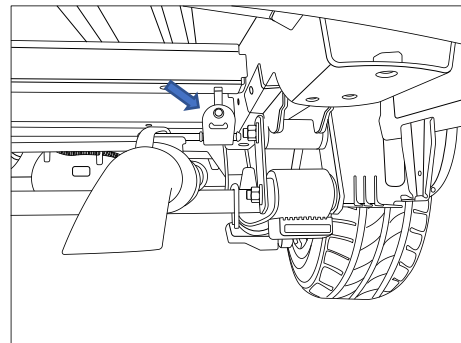

-
12. Remove the Grommet covering the hole under the chassis rail. Insert T-Bolt through the uncovered hole.

Repeat for the other side

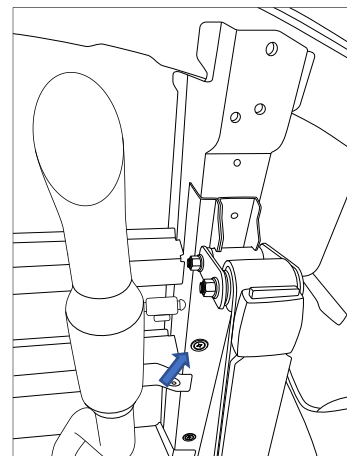

-
13. Attach the RH Sidearm to by inserting the 2 x M12 x 150 Bolts, ensuring the T-Bolt is sticking through – Using 1x M10 Washer and 1 X M10 Nut, and 2 x M12 Washers and 2 X M12 Nuts, and tighten the Side Arm to the chasis rail.

Repeat for the other side

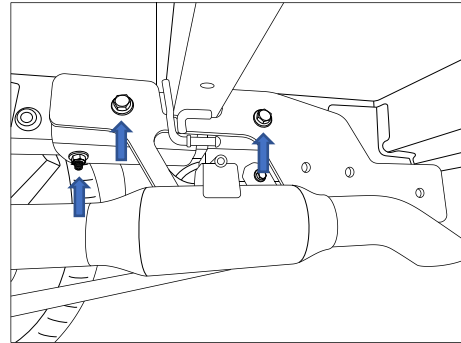

-
14. Mark out the inside of the front slot on the Chasis rail. Using a 5mm dill bit, drill a pilot hole.

Remove the side arm and drill a 23mm hole using the pilot hole as the center guide, (Gradually increase the drill bit size)

Note: Ensure that the bare metal surfaces is coated in bare metal primer and touch up pint or suitable automotive rust inhibitor.

Repeat for the other side

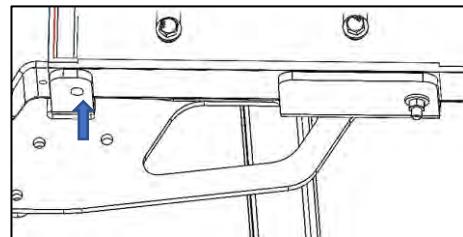

-
15. Insert the additional T-Bolt into the drilled hole

Repeat of the other side

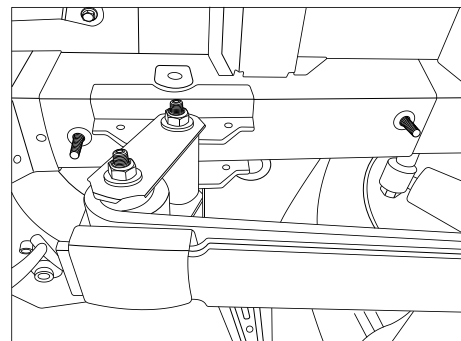

-
16. Refit the Sidearm to the chassis rail by inserting the 2 x M12 x 150 Bolts, ensuring the T-Bolts are sticking through – Loosely secure to the Chassis Rail using 2x M10 Washer and 2 X M10 Nut, and 2 x M12 Washers and 2 X M12 Nuts.

Repeat for the other side

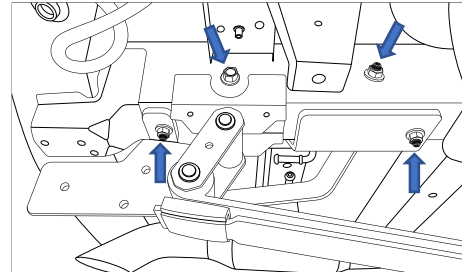

-
17. Fit the towbar to the side arms and loosely secure using 3 x M12 x 50 Bolts, 5 x M12 Washers and 2 x M12 Nuts

Repeat for the other side

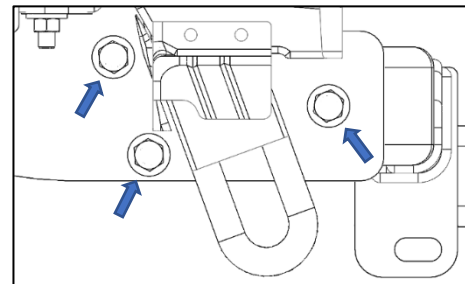

-
18. Torque all fasteners as assembled in steps 16 & 17 on both sides as follows
M12 x 1.75P = 109Nm
M10 x 1.5P = 44Nm

19. On the rear bumper, If present, remove 2 x screws holding the key sensor antenna.

Remove 2 x bumper scrivenets and unscrew the 1x screw connecting to the support beam.

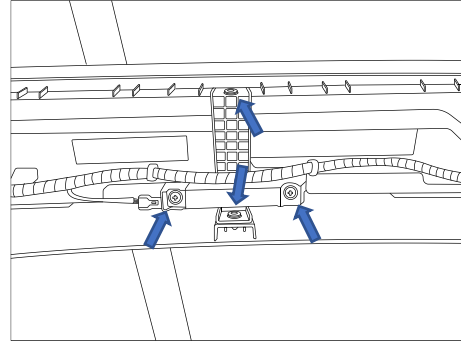

20. Remove material from the hard plastic support on the rear bumper interior as shown a depth of 12mm.

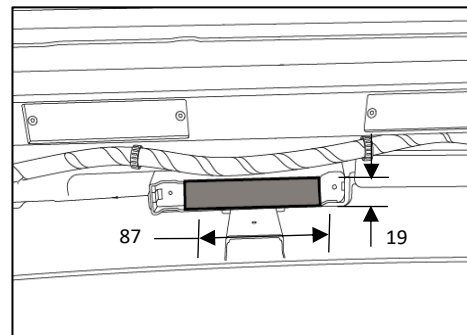

21. Place masking tape on the bumper outer skin, Mark and cut out an area as show to clear the hitch box.

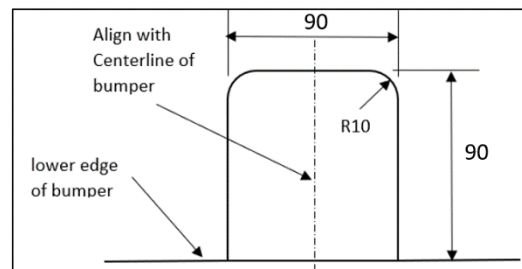

-
22. Cable Tie the key sensor antenna out of the way of the towbar opening as shown

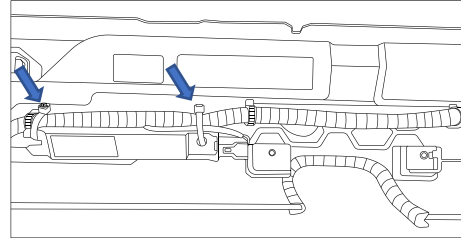

The following Steps are for the Staria Load 2P and 5P. Proceed to Step 10 for the 8 seat Staria People Mover.

23. From inside the vehicle, remove 12 scrivets (1) from the RHS luggage compartment trim (2).
24. Remove the RHS luggage compartment trim (2).

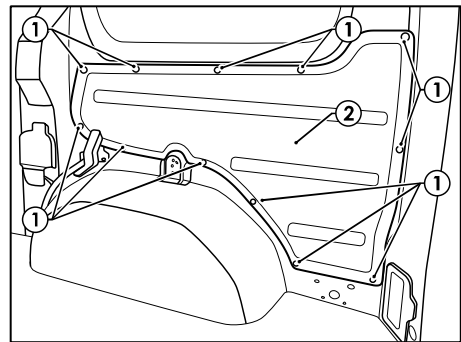

-
25. Secure the white M6 ground wire ring terminal to the vehicle earthing point (1) on the luggage compartment RHS.
26. Route the Trailer Wiring Harness following the existing factory vehicle harness (2).

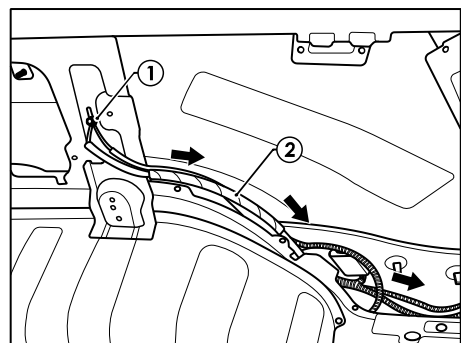

27. Clean ECU mounting location (1) shown and base of ECU (2) using supplied cleaning pad.
28. Connect the Trail Harness 12-Way Connector (3) to ECU (2) and mount in the location shown using the supplied Double-Sided Tape.
29. Secure Trailer Harness (4) to existing Vehicle Harness using supplied 200mm Cable ties.

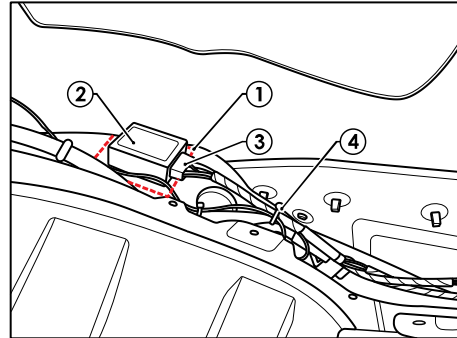

30. Remove the tape covering the 13-way male connector (1) from the vehicle harness.
31. Remove and discard the 13-way blanking plug if present.
32. Connect the Trailer Wiring Harness 13-way female connector (2) to the vehicle harness 13-way male connector (1).

Proceed to step 51.

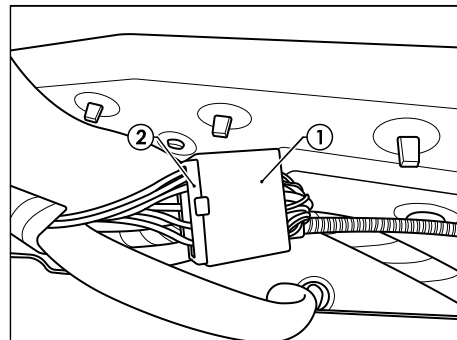

The following Steps are for the 8 seat Staria People Mover.

33. At the Rear RHS of the vehicle, Undo the upper bolt holding the RHS third row seat belt and dislodge the seat belt.
34. Open the RHS third-row glass window and remove the D Pillar inner trim.

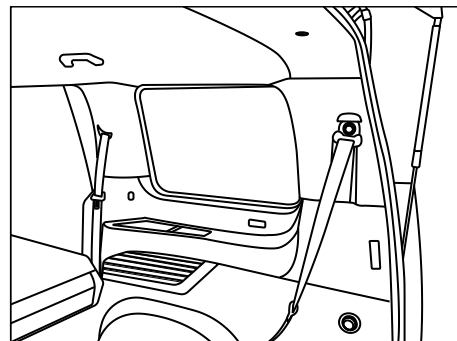

-
35. Remove the RHS C Pillar air bag trim cap (1) and 10mm bolt underneath it.
 36. Dislodge and remove the RHS C Pillar trim (2).

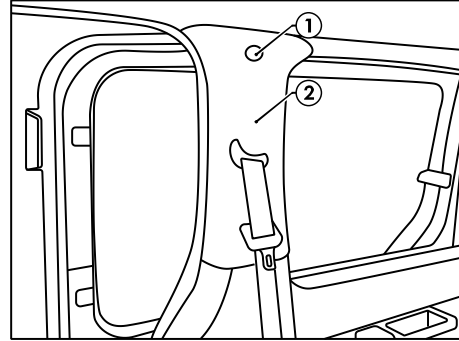

-
37. Remove RHS Second row seat belt bolt cover (1) and 14mm bolt.

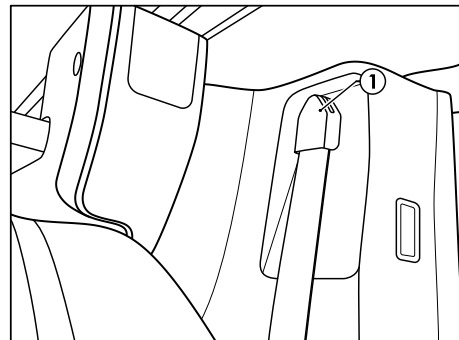

-
38. Lay the second and third row seats down and move them forwards.
 39. Remove the RHS third row seat belt bolt cover.
 40. Remove the plastic bolt cover.
 41. Remove four M6 bolts.
 42. Remove the rear scuff trim.
 43. Dislodge and remove the rear compartment trim.

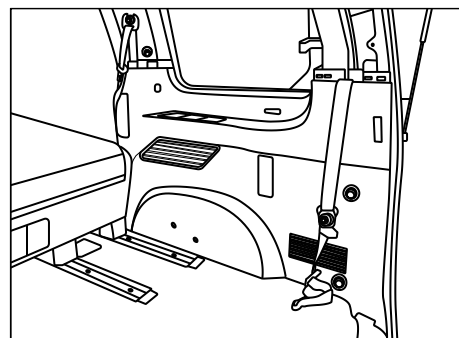

44. Locate the 13-way male vehicle connector (1) and remove 13-way blanking plug.
45. Connect the 13-way female connector on the trailer wiring harness to the 13-way on the vehicle harness.
46. Route the trailer wiring harness towards the front of the vehicle and secure the M6 ground wire ring terminal to the vehicle earthing point.

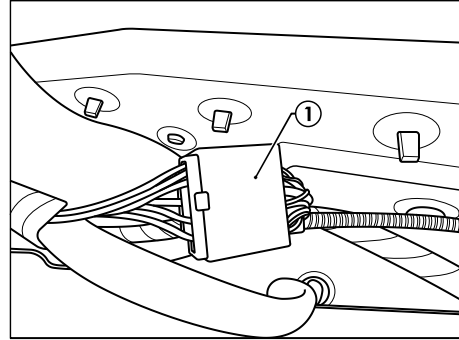

47. Clean ECU mounting location (1) shown and base of ECU (2) using supplied cleaning pad.
48. Connect the Trail Harness 12-Way Connector (3) to ECU (2) and mount in the location shown using the supplied Double-Sided Tape.

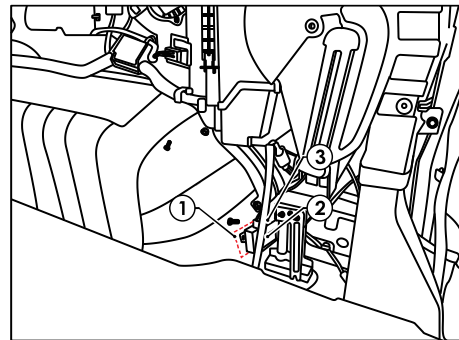

49. At the RHS rear of the vehicle, remove the existing grommet (1) and drill out the hole to 30mm.

Note: Remove sharp edges and spray rust inhibitor.

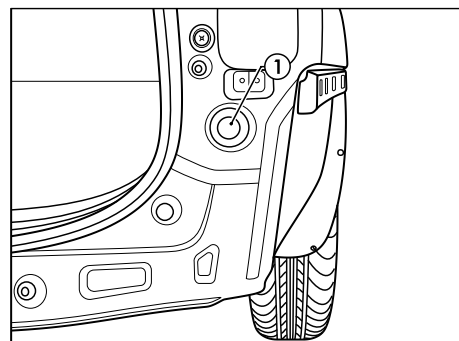

-
50. With the rear bumper removed, secure tail harness to towbar.
 51. Route tail harness up through chassis and previously drilled 30mm hole.
 52. Seat grommet in 30mm hole and route to trailer harness blue connector on patch loom.
Note: Keep harness routing clear of all sharp edges, moving parts and places of extreme heat.
Note: Ensure grommet is seated correctly and makes a good seal.

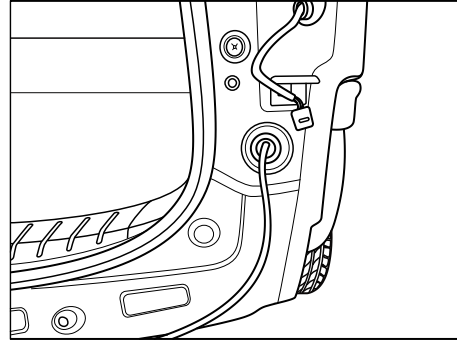

-
53. Connect the tail harness (tail length 1800mm) 8-way connector (1) to the trailer patch mating 8-way connector (2).
 54. Secure all harness using supplied cable ties.
 55. Refit all removed parts and secure all fasteners, ensuring there are no squeaks or rattles following steps 1-8, 23 (2P-5P), 33-43 (8 seat people mover) in reverse.
 56. Refit the spare wheel ensuring the spare wheel is pushed forward slightly to pass the towbar.
Note: The spare wheel will sit snug up behind the towbar.
 57. Test the trailer patch function using a light board or multimeter.
 58. Place the fitting instructions in the glove box after fitment.

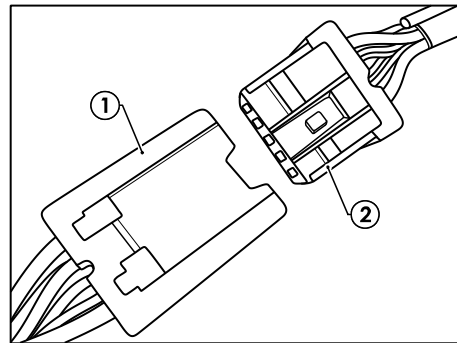



CUSTOMER INFORMATION

PLACE THESE INSTRUCTIONS IN THE
VEHICLE'S GLOVEBOX AFTER INSTALLATION

**THANK YOU FOR PURCHASING TRAILBOSS. WITH CORRECT MAINTENANCE AND CARE
THIS PRODUCT WILL PROVIDE A LIFETIME OF TROUBLE-FREE OPERATION.**

TOWBAR MAINTENANCE AND CARE:

1. Trailboss recommend that the towbar LUG or TBM (Trailer Ball Mount) Pull Pin and R-clip are removed and stored when not in use. Removal of LUG or TBM (Trailer Ball Mount) is advisable when not in use to assist with any of the following.
 - Ensure rear number plate is not obscured.
 - Allow maximum available departure angle and prevent any potential interference.
 - Prevent possible interference with vehicles reverse sensors or camera detecting a tow ball mount as an obstruction during reversing.
 - Removes towball mount as an obstruction for when moving around the rear of the vehicle.
2. Trailboss recommends routine inspection of your towbar to ensure trouble free towing.
 - Bolt security and tension should be regularly inspected and checked for correct tension. Replace any worn or defective parts with suitable grade & class fasteners. Inspection should be requested to coincide with vehicle major services.
3. It is the owner's responsibility to ensure towing and down ball weight capacities of the towing vehicle are not exceeded.
 - Towing and down ball weights allowable may differ according to model variations. Please refer to owner's manual or vehicle dealer to confirm exact rating for your vehicle model variant.
 - It is not uncommon for the vehicle tow rating to differ from the towbar rating. When this occurs, the lesser rating must be adhered to.
 - For vehicles fitted with enhanced vehicle functions that may be altered/changed when towing i.e Trailer sway mitigation, blind spot detection, adaptive cruise control etc. Please consult owner's manual to understand changes enabled when towing and after towing.

WARRANTY INFORMATION:

Trailboss Towbars are covered by a Lifetime Warranty.

Our goods come with guarantees that cannot be excluded under the Australian Consumer Law. You are entitled to a replacement or refund for a major failure and for compensation for any other reasonably foreseeable loss or damage. You are also entitled to have the goods repaired or replaced if the goods fail to be of acceptable quality and the failure does not amount to a major failure.

For further details please contact customer service on 1800 812 017.

PRO SERIES SILENT ANTI-RATTLE HITCH PIN

Your Trailboss towbar is equipped with a Pro Series Silent Anti-Rattle Hitch Pin technology to help reduce towbar tongue rattle in most driving conditions. Please ensure below instructions are understood and routine maintenance is carried out to ensure best towing experience.

Regularly inspect for wear and check the tightness of the Silent Anti-Rattle Hitch Pin. Follow instructions below to re-tighten the nut as necessary when movement and noise in the tow ball mount is noted.

- Before towing, ensure R-Clip is properly installed and hitch pin nut is installed and tensioned. Replacement parts are available from your Pro Series Distributor.

TOWBALL MOUNT REMOVAL/INSTALLATION

STEP 1

Insert Trailer Ball Mount (TBM) (a) into towbar hitchbox (b), aligning hole in TBM shank (c) with hole in hitchbox (d) (Fig. 1)

STEP 2

Insert Silent Anti-Rattle Hitch Pin (e) through hole in hitchbox and hole in TBM shank (g); ensure the locators are inserted into the notches in the hitchbox (Fig. 2)

STEP 3

Screw Silent Anti-Rattle Hitch Pin Nut (f) onto Smart Pin (g); tighten Smart Pin Nut until finger tight, ensuring TBM is restrained from up and down movement.

STEP 4

Tighten Silent Anti-Rattle Hitch Pin Nut by turning nut a further 1/8th of a turn in the clockwise direction using a 24mm spanner (Fig. 4).

STEP 5

Install Silent Anti-Rattle Hitch Pin R-Clip through the hole that provides best clearance or easiest access. (Fig. 5)

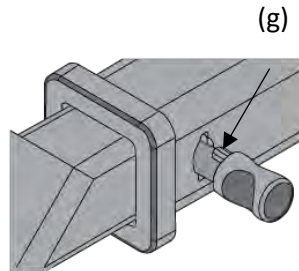
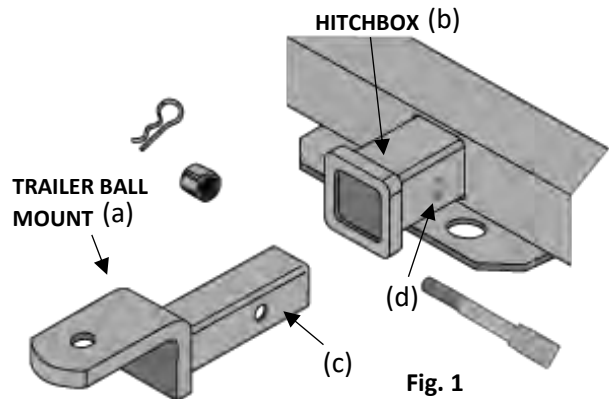

Fig. 2

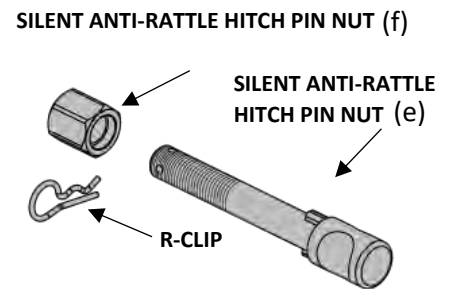

Fig. 3

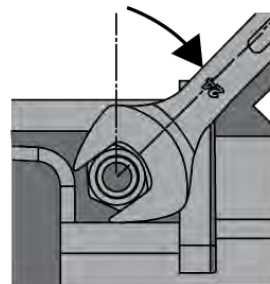

Fig. 4

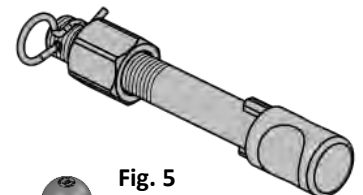

Fig. 5

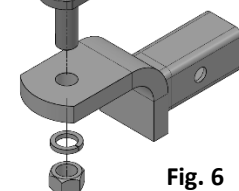

Fig. 6