

**PRODUCT DETAILS:**

---

<b>Part Number:</b>	QTIS6L	<b>Maximum Towing Braked:</b>	3500	kg
<b>ECU Number:</b>	04835	<b>Maximum Towing Unbraked:</b>	750	kg
<b>Tail Harness Length Required:</b>	102462-WL	<b>Maximum Static Ball Load:</b>	350	kg

---

**FITTING DETAILS:**

---

<b>Towbar Installation Time:</b>	10 Mins	<b>RPA Disable/Other:</b>	YES
<b>Total Installation Time:</b>	30 Mins		
<b>Bumper Cut Required:</b>	No		

---

**Note:**

- 04943 (7 Pin) or 04941 (12 Pin) tail must be used to disable RPA.
- TBM Kit provides compliant ball mount/Wiring/ECU & Hardware.

### ENSURE THAT INSTRUCTIONS ARE UNDERSTOOD PRIOR TO FITMENT.



#### **Warning:**

1. Do not, drill, cut, weld or otherwise modify the towbar.
2. If you are using electric welding on a motor vehicle, **always** check that the vehicle is not equipped with electronic engine or instrument management equipment. Failure to do so could **destroy** any on board computers. If in doubt, check with the vehicle's manufacturer.
3. If TBM is used in inverted position tow ball may make contact with rear tailgate when lowered, which could cause damage.

#### **General:**

1. Ensure all hardware items have been included refer to assembly diagram.
2. It is recommended that the instructions are read through and completely understood before making any attempt to fit this product.
3. Be wary of any changes to vehicle designs or other accessories that may conflict with the installation of this product.
4. Before drilling ensure that the area is clear of fuel, electrical & other components.
5. All holes drilled into the body panels shall have all burrs & swarf removed then coated with a suitable rust preventative paint.
6. The high tensile fasteners supplied with this product were used to achieve the specified rating. If replacement is required ensure that fasteners of the same rating & quality are used. Contact an authorised **Trailboss** dealer if further information is required.
7. Ensure that all hardware is fastened to torque list below check fasteners on regular basis.
8. Towbar load rating sticker provided with this product shall be conspicuously located on inside rear end of the driver's door. **(See diagram below).**
9. Trailboss recommends that you check your tow ball to ensure that it complies with the Australian standards **AS 4177.2**.
10. **PLEASE NOTE:** It is advised to remove your LUG or TBM when not actually towing so as to produce a clear view of the vehicles registration plate if obscured, and to also provide maximum available departure angle.

#### **Tow bar Maintenance and Care.**

Trailboss recommends that bolt torque's, as listed below, are routinely and regularly inspected and checked for correct tension. Replace any worn or defective parts.

We recommended to remove Tow Ball Mounts (TBM's, tongues or lugs) when not being used for any considerable length of time.

So as to avoid injury, when not towing it is suggested that the tongue, Pull Pin and R-clip are removed then stored in a safe, clean and dry place, away from excessive moisture.

Hitch Pull Pins and spring "R" clips are regularly checked for proper installation. Replace any worn or defective parts.

**FOR TOWING PURPOSES ONLY**  
**For towing capacity details please refer to vehicle owner's manual or to the manufacturer. Overloading can void your warranties.**

### **i** TOWBAR ASSEMBLY DIAGRAM

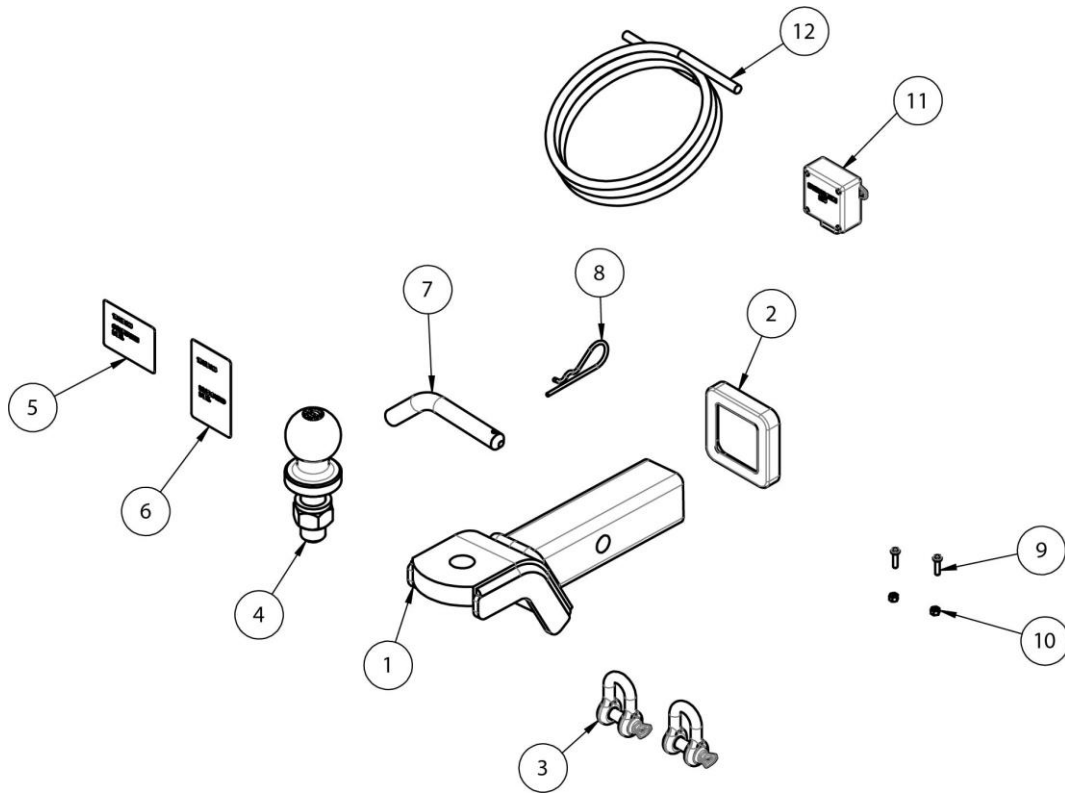

ITEM	DESCRIPTION	QTY
1	TRAILER BALL MOUNT	1
2	HITCH BOX COLLAR COVER	1
3	"D" SHACKLE 10mm	2
4	TOWBALL 50mm	1
5	COMPLIANCE LABEL	1
6	LOAD RATING LABEL	1
7	PULL PIN	1
8	R CLIP	1
9	NUT NYLOC HEX HD M4x0.7P	2
10	SCREW PAN HD M4x16x0.7P	2
11	ELECTRICAL UNIT	1
12	WIRING LOOM	1

1. Install towball onto TBM and tighten to 350 Nm  
Using a calibrated torque wrench.

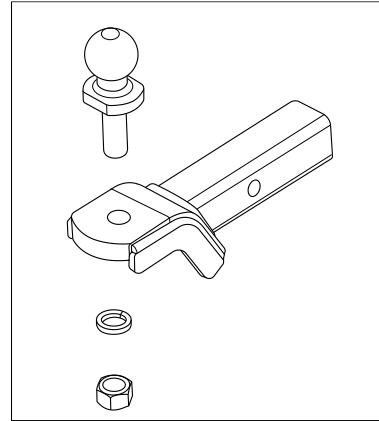

2. Fit TBM assembly to the towbar hitch receiver in the upward-position and secure with PullPin. Ensure to fit the R-Clip to the Pull Pin.

Fit the D-Shackles to the chain connection lugs.

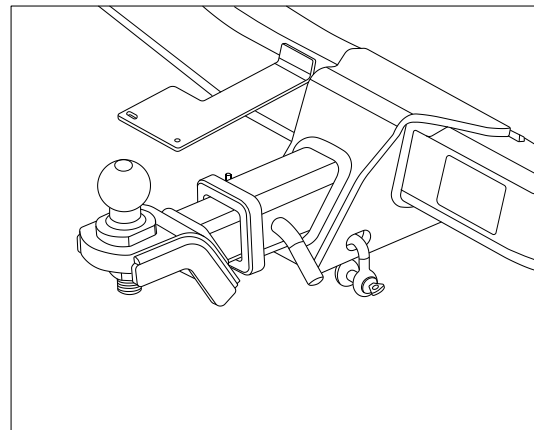

3. Affix the TBM kit compliance label onto the towbar.  
Place load rating sticker inside driver's door next to existing towbar load rating label.

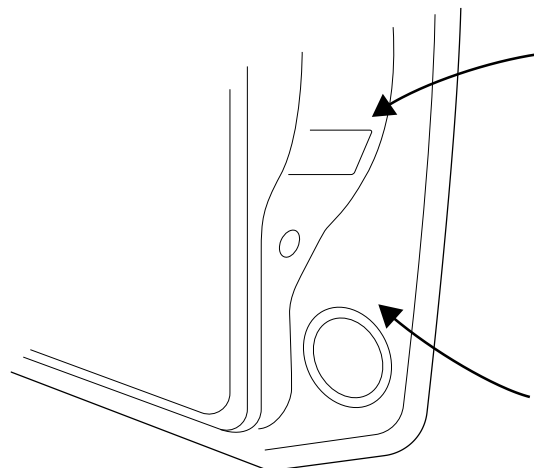

### IMPORTANT

Due to possible vehicle variations, always confirm any noted vehicle colour wires with a multi-meter to ensure the correct function is identified before soldering or scotch locking. For vehicle wires denoted with two colours (example; RED/GREEN) the first colour will always be the main wire colour while the second colour is the thinner trace colour on the wire.

4. On the LHS for the chassis locate the 8-way breakout connector and remove the blanking plug (1).
5. Plug in the trailer patch (102462-WL) in to the mating vehicle.

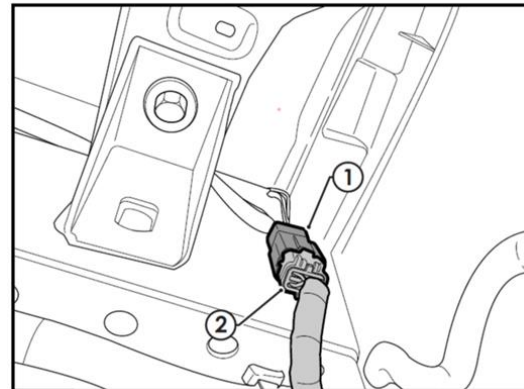

6. Connect the trailer patch 24-way connector (1) to the ECU (04835) (2).
7. Secure the ECU to the chassis using tek screws or cable tie (not supplied).

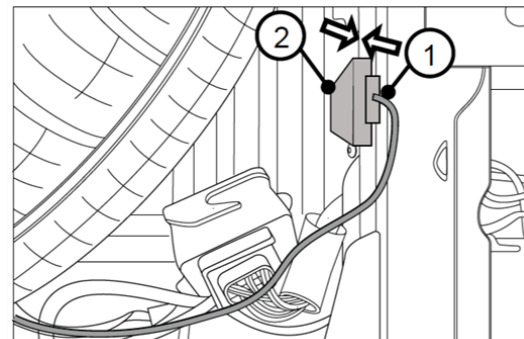

8. Mount the trailer socket (1) to the plug bracket.
9. Route the tail harness blue connector (2) (tail length 1200mm) towards the trailer patch mating connector.

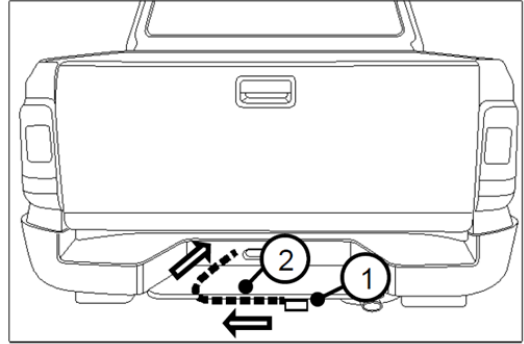

10. Connect the tail harness 8-way connector (1) to the trailer patch mating 8-way connector (2).
11. Strip and crimp, GREY (3) and GREY/BLACK (4) wires to the RPA patch matching GREY (5) and GREY/BLACK (6) wires and insulate connections.
12. Apply silicon grease (7) (not provided) to the blue connectors to prevent water ingress.

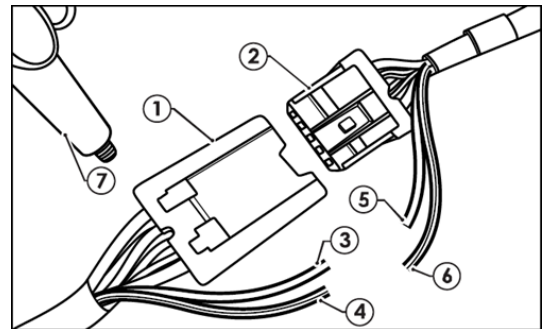

13. Test the trailer patch function using a light board or multi-meter.
14. Secure all harness using cable tie (not supplied).
15. Place fitting instructions in glovebox after fitment.



## CUSTOMER INFORMATION

PLACE THESE INSTRUCTIONS IN THE VEHICLE'S GLOVEBOX AFTER INSTALLATION

**THANK YOU FOR PURCHASING TRAILBOSS. WITH CORRECT MAINTENANCE AND CARE THIS PRODUCT WILL PROVIDE A LIFETIME OF TROUBLE-FREE OPERATION.**

### **TOWBAR MAINTENANCE AND CARE:**

1. Trailboss recommend that the towbar LUG or TBM (Trailer Ball Mount) Pull Pin and R-clip are removed and stored when not in use. Removal of LUG or TBM (Trailer Ball Mount) is advisable when not in use to assist with any of the following.
  - Ensure rear number plate is not obscured.
  - Allow maximum available departure angle and prevent any potential interference.
  - Prevent possible interference with vehicles reverse sensors or camera detecting a tow ball mount as an obstruction during reversing.
  - Removes towball mount as an obstruction for when moving around the rear of the vehicle.
2. Trailboss recommends routine inspection of your towbar to ensure trouble free towing.
  - Bolt security and tension should be regularly inspected and checked for correct tension. Replace any worn or defective parts with suitable grade & class fasteners. Inspection should be requested to coincide with vehicle major services.
3. It is the owner's responsibility to ensure towing and down ball weight capacities of the towing vehicle are not exceeded.
  - Towing and down ball weights allowable may differ according to model variations. Please refer to owner's manual or vehicle dealer to confirm exact rating for your vehicle model variant.
  - It is not uncommon for the vehicle tow rating to differ from the towbar rating. When this occurs, the lesser rating must be adhered to.
  - For vehicles fitted with enhanced vehicle functions that may be altered/changed when towing i.e Trailer sway mitigation, blind spot detection, adaptive cruise control etc. Please consult owner's manual to understand changes enabled when towing and after towing.

### **WARRANTY INFORMATION:**

Trailboss Towbars are covered by a Lifetime Warranty.

Our goods come with guarantees that cannot be excluded under the Australian Consumer Law. You are entitled to a replacement or refund for a major failure and for compensation for any other reasonably foreseeable loss or damage. You are also entitled to have the goods repaired or replaced if the goods fail to be of acceptable quality and the failure does not amount to a major failure. For further details please contact customer service on 1800 812 017.