

TRAILBOSS

Towbar Fitting Instructions

To Suit **IVECO DAILY VAN 35 SERIES – HIGH ROOF (3520L & 4100)**

Part Number **QTIV03L**

Rating **3500/250 kg**

PLACE THESE INSTRUCTIONS IN THE VEHICLE'S GLOVEBOX AFTER INSTALLATION IS COMPLETED

WARNING:

1. Do not, drill, cut, weld or otherwise modify the tow bar.
2. If you are using electric welding on a motor vehicle, **always** check that the vehicle is not equipped with electronic engine or instrument management equipment. Failure to do so could **destroy** any onboard computers. If in doubt, check with the vehicle's manufacturer.
3. The high tensile fasteners supplied with this product were used to achieve the specified rating. If replacement is required ensure that fasteners of the same rating & quality are used. Contact an authorised **Trailboss** dealer if further information is required.
4. If TBM is used in inverted position tow ball may make contact with rear tailgate when lowered, which could cause damage.

General:

1. Ensure all hardware items have been included refer to assembly diagram.
2. It is recommended that the instructions are read through and completely understood before making any attempt to fit this product.
3. Be wary of any changes to vehicle designs or other accessories that may conflict with the installation of this product.
4. Before drilling ensure that the area is clear of fuel, electrical & other components.
5. All holes drilled into the body panels shall have all burrs & swarf removed then coated with a suitable rust preventative paint.
6. For vehicles that require the bumper to be cut. Ensure cut out area is in correct position on the vehicle prior to cutting the bumper.
7. The high tensile fasteners supplied with this product were used to achieve the specified rating. If replacement is required ensure that fasteners of the same rating & quality are used. Contact an authorized **Trailboss** dealer if further information is required.
8. Ensure that all hardware is fastened to torque list below check fasteners on regular basis.
9. Tow bar load rating sticker provided with this product shall be conspicuously located on inside rear end of the driver's door. **(See diagram below).**
10. Trailboss recommends that you check your tow ball to ensure that it complies with the Australian standards **AS 4177.2**.
11. **PLEASE NOTE:** It is advised to remove your lug or tbm when not actually towing so as to produce a clear view of the vehicles registration plate if obscured, and to also provide maximum available departure angle
12. Pull Pin must be fit in down position.

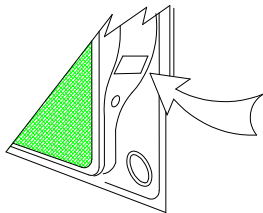

Place load rating sticker
inside driver's door here

FOR TRAILER TOWING PURPOSES ONLY
For towing capacity details please refer to vehicle owner's manual or to the manufacturer. Overloading can void your warranties.

RECOMMENDED ASSEMBLY TORQUE LISTING

Diameter	Grade 8.8 Bolt
M6	9.5 Nm
M8	21.7 Nm
M10	43.4 Nm
M12	77.3Nm
M14	146 Nm
M16	189.8 Nm

Tow bar Maintenance and Care.

Trailboss recommends that bolt torque's, as listed below, are routinely and regularly inspected and checked for correct tension. Replace any worn or defective parts.

We recommended to remove Tow Ball Mounts (TBM's, tongues or lugs) when not being used for any considerable length of time.

So as to avoid injury, when not towing it is suggested that the tongue, Pull Pin and R-clip are removed then stored in a safe, clean and dry place, away from excessive moisture.

Hitch Pull Pins and spring "R" clips are regularly checked for proper installation. Replace any worn or defective parts.

TRAILBOSS

Towbar Fitting Instructions

To Suit **IVECO DAILY VAN 35 SERIES – HIGH ROOF (3520L & 4100)**

Part Number **QTIV03L**

Rating **3500/250 kg**

PLACE THESE INSTRUCTIONS IN THE VEHICLE'S GLOVEBOX AFTER INSTALLATION IS COMPLETED

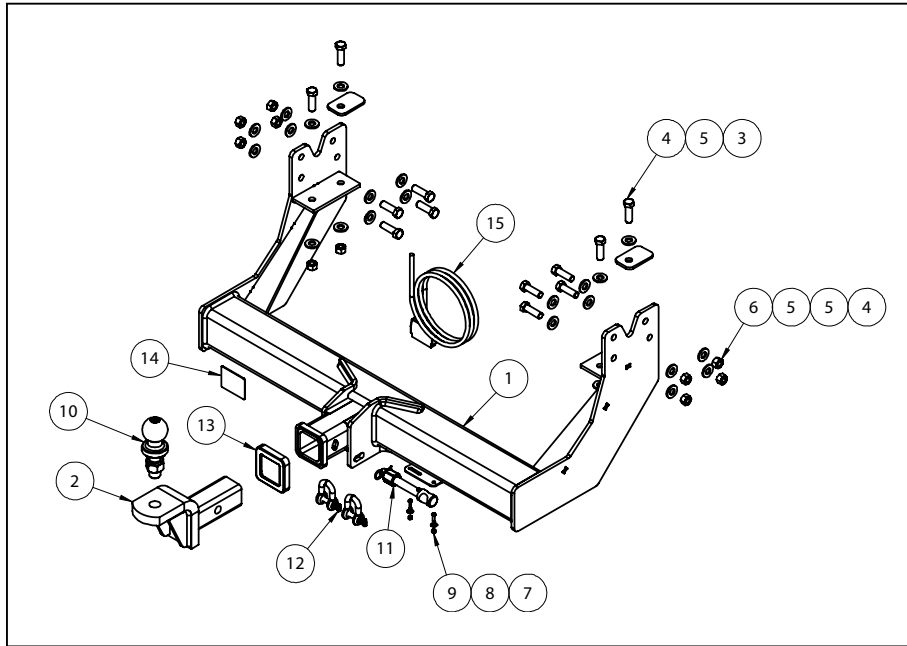

QTY.	DESCRIPTION	ITEM NO.
1	WELDED ASSEMBLY	1
1	TRAILER BALL MOUNT ASSY	2
2	SPACER PLATE	3
12	SET SCREW M12x40x1.75P	4
24	WASHER FLAT 1/2"x1 1/8"x1/8"	5
12	HEX NUT M12x1.75 PC8	6
2	SCREW PAN xr mts M4-0.7x16 Z/P	7
2	F/WASHER 3/16 x1/2 ZP	8
2	NUT NYLOC M4-0..7 Z/P	9
1	50mm TOWBALL	10
1	SILENT HITCH PIN-SILVER	11
2	10mm "D" SHACKLE	12
1	HITCH BOX COLLAR COVER	13
2	ACRYLIC COMPLIANCE PLATE	14
1	WIRING LOOM	15



Towbar Fitting Instructions

To Suit **IVECO DAILY VAN 35 SERIES – HIGH ROOF (3520L & 4100)**

Part Number **QTIV03L**

Rating **3500/250 kg**

PLACE THESE INSTRUCTIONS IN THE VEHICLE'S GLOVEBOX AFTER INSTALLATION IS COMPLETED

INSTRUCTION:

1. Remove and discard 1x forward vertical Bolt securing rear step to chassis rail. Repeat for opposite side of vehicle.
2. Loosely secure Towbar to outboard faces of chassis rail using 4x M12 Set Screws per chassis rail, complete with 2x M12 Flat Washers and 1x M12 Nut per Set Screw.
3. Using a spacer for the forward mounting point, loosely secure Towbar to underside of chassis rail using 2x M12 Set Screws, complete with 2x M12 Flat Washers and 1x M12 Nut per Set Screw. Repeat for opposite side of vehicle.
4. Tighten all fasteners to torques listed on page 1 of this document.



Wiring Loom Fitting Instructions
To Suit Iveco Daily
Part Number 101346-WL

Wiring Loom Installation Instructions

Iveco Daily
Part No: 101346-WL

Tail Harness Length Required: 1200mm

Wiring Loom Installation Time: Approx 10 Mins



Wiring Loom Fitting Instructions
To Suit Iveco Daily
Part Number 101346-WL

1. At the LHS rear quarter near the spare tyre, locate the vehicle ECU.
2. Connect the trailer patch (P/No: 101346-WL) 12-way connector to the ECU RHS connector.
3. Secure the trailer patch ground ring terminal to the vehicle bolt on the reverse side of the ECU bracket.
4. Mount the trailer socket to the towbar mounting bracket using M4 fasteners (not supplied).
5. Route the tail harness (tail length 1200mm) towards the trailer patch.
6. Connect the tail harness 8-way connector to the trailer patch 8-way mating connector.
Waterproof the trailer patch 8-way connector and the tail harness 8-way male connector using silicone or electrical grease.
7. Test the Trailer Harness function using a light board or multi-meter.
8. Secure all harnesses using cables ties (not supplied).
9. Re-fit all removed parts and secure all fasteners, ensuring there are no squeaks or rattles.
10. Place the instructions in the glove box after fitment.



FITTING INSTRUCTIONS

Silent Anti-Rattle Hitch Pin (PR0001)

• These fitting instructions are supplied to ensure understanding of how the HITCH PIN should be fitted and used correctly.

• Once installed, we recommend **ALL** instructions are kept and placed in the vehicle glove box.

NOTE: Routine maintenance and inspection of the towbar & HITCH PIN is required. Regularly inspect for wear and check the tightness of the Hitch Pin. Follow instructions below to retighten the nut when necessary.

***Do not tow with your vehicle if the R CLIP or the HITCH PIN is loose or missing. Replacement parts are available from your Pro Series Distributor.**

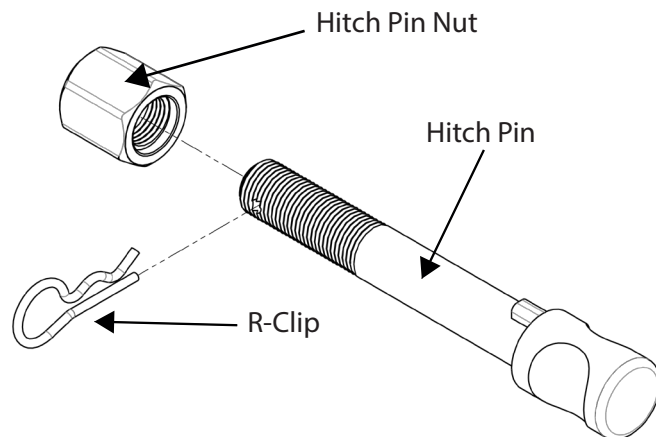

Fig 1. Silent Anti-Rattle Hitch Pin assembly

STEP 1

Insert Trailer Ball Mount (TBM) into towbar HITCHBOX, aligning hole in TBM SHANK with hole in HITCHBOX (Fig 2).

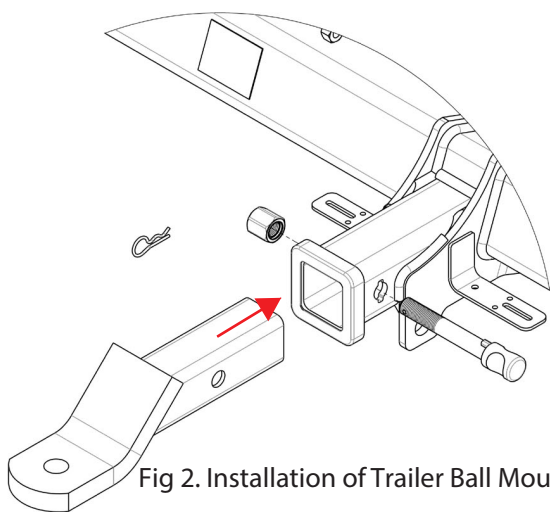

Fig 2. Installation of Trailer Ball Mount

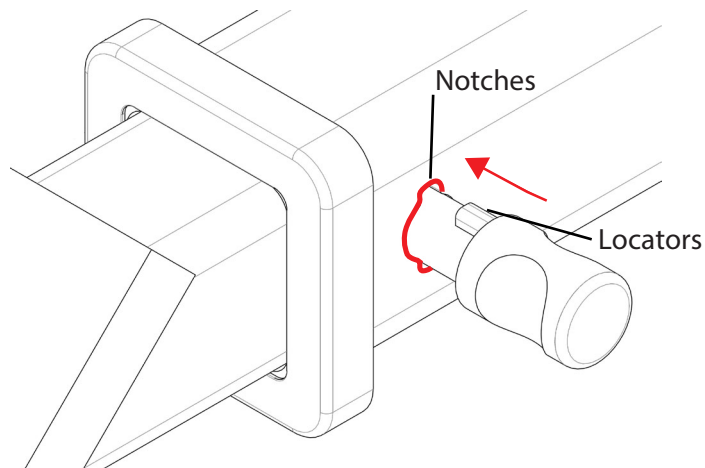

Fig 3. Silent Anti-Rattle Hitch Pin orientation

STEP 2

Insert HITCH PIN through hole in HITCHBOX and hole in TBM SHANK; ensure the LOCATORS are inserted into the NOTCHES in the HITCHBOX (Fig. 3).

STEP 3

Screw HITCH PIN NUT onto HITCH PIN; tighten HITCH PIN NUT until finger tight, ensuring TBM is restrained from movement.

STEP 4

Tighten HITCH PIN NUT by turning nut a further 1/8th of a turn in the clockwise direction using a 24mm spanner (Fig. 4).

STEP 5

Install HITCH PIN R CLIP through the hole on the HITCH PIN (Fig. 1).

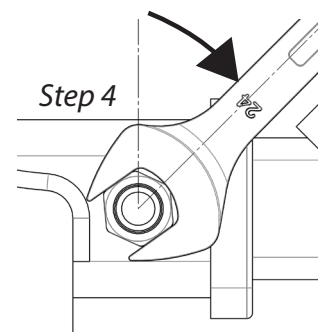

Fig 4. Tightening of Silent Anti-Rattle Hitch Pin Nut