

PRODUCT DETAILS:

Part Number:	QTJP20L	Maximum Towing Braked:	2200	kg
ECU Number:	04826	Maximum Towing Unbraked:	750	kg
Tail Harness Length Required:	400 mm.	Maximum Static Ball Load:	220	kg
TBM/Lug Part Number:	21247			

FITTING DETAILS:

Towbar Installation Time:	70 Mins.	RPA Disable/Other Notes:	YES
Total Installation Time:	130 Mins.		
Bumper Cut Required:	Yes		

Note:

- RPA Disable – Button near hazard switch
- Electric Brake Input Location: Inside vehicle near ECU

TRAILBOSS RECOMMENDS THAT INSTRUCTIONS ARE READ AND UNDERSTOOD COMPLETELY PRIOR TO FITMENT.

BEFORE YOU START:

Check all hardware items have been included refer to assembly diagram.
Please ensure this towbar is only fitted to vehicle models as per Trailboss application guide.

Bumper Cuts

Vehicle and bumper variations can and do occur during vehicle manufacture after initial towbar design. Fitment of towbar to vehicle and accuracy of bumper cut must be assessed prior to any bumper modifications made. Incorrect bumper cuts are not covered under Trailboss warranty.

NOTE: Bumper cuts need to be approached with care, refer to notes below.

- Bumper centreline – where the centreline of the bumper needs to be determined, the installer must assess centre point by measurement of bumper width or determining two symmetrical reference points to give centreline.
- Bumper edge – To assist with accurate bumper cut measurement, reference to the start of the bumper edge is now being commonly used.
 - Measure from bottom edge along bumper and around corner to the 70 mm point (Figure 1).
 - Do not measure from visible bumper front of corner, upwards (Figure 2).

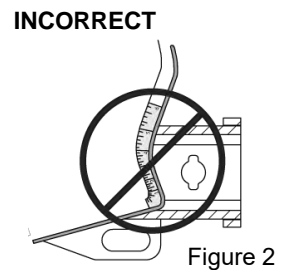
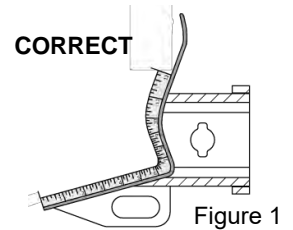

Drilling

- For any required drilling during installation, ensure that the area is clear of fuel, electrical & other components that may be damaged.
- All holes drilled into metal body panels shall have all burrs & swarf removed then coated with a suitable rust preventative paint.

Bolts/Fasteners

- Ensure that all hardware is fastened to correct torque as specified in this fitting instruction.
- All fasteners supplied with this product are used to achieve a specified clamp loading. If replacement is required ensure that fasteners of the same grade and class are used.

NOTE: Achieving correct torque is critical to proper installation and responsibility of the installer. Towbar failures attributed to tension issues from over tightening or under tightening are not covered by Trailboss warranty.

Product Labels

- a. Towbar load rating sticker provided with this product shall be conspicuously located on inside rear end of the driver's door.

WARNING:

Do not, drill, cut, weld or otherwise modify the towbar.

FOR TOWING PURPOSES ONLY - This towbar is designed and tested by Trailboss to adhere to ADR 62/02 which provides only for the expected load demands of towing.

i TOWBAR ASSEMBLY DIAGRAM

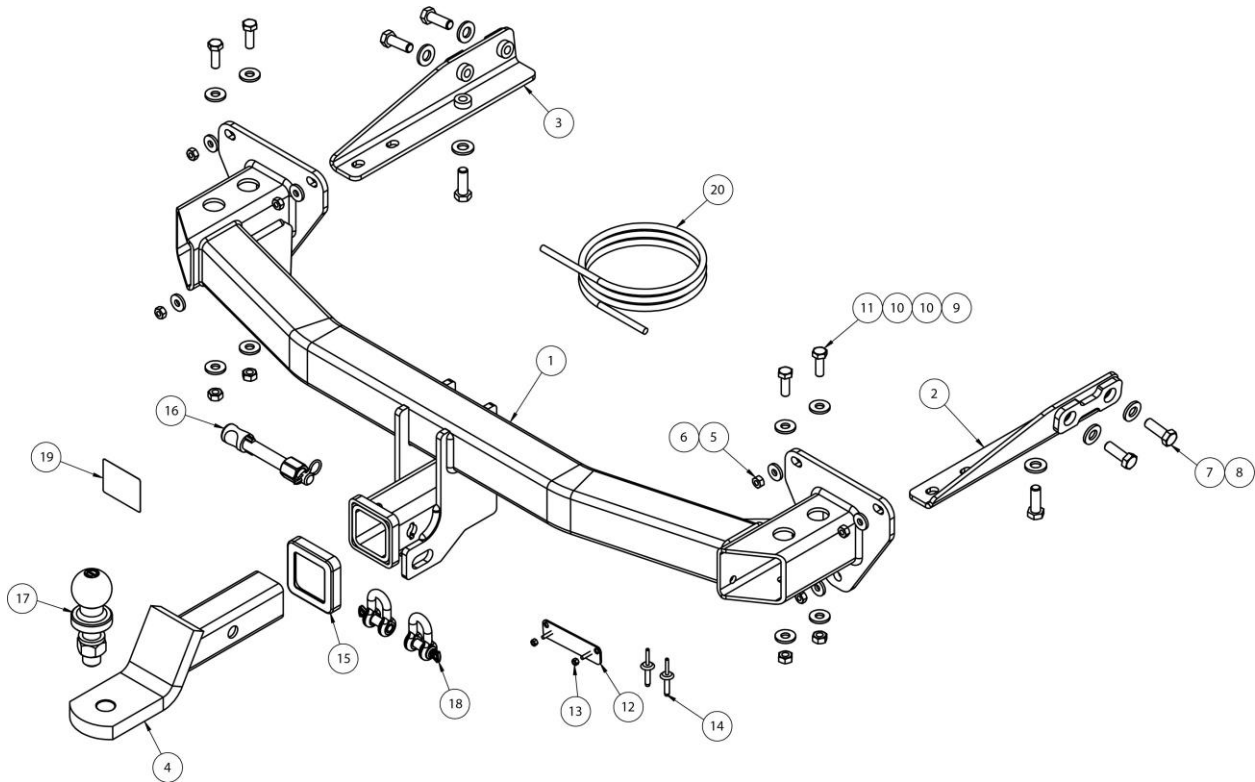

ITEM	DESCRIPTION	QTY
1	JEEP CHEROKEE KL WELDED ASSEMBLY	1
2	SIDE ARM RHS	1
3	SIDE ARM LHS	1
4	TRAILER BALL MOUNT	1
5	NUT HEX M8x1.25P	6
6	WASHER PLAIN M8x22x3	6
7	SET SCREW HEX HD M12x35x1.25P	6
8	WASHER PLAIN 1/2x1-1/81x16	6
9	NUT HEX M10x1.25P	4
10	WASHER PLAIN M10x25x3	8

ITEM	DESCRIPTION	QTY
11	SET SCREW HEX HD M10x30x1.25P	4
12	PLUG BRACKET	1
13	NUT NYLON LOCK HEX M4x0.7P	2
14	POP RIVET	2
15	HITCH BOX COLLAR COVER	1
16	SILENT HITCH PIN – SILVER	1
17	50mm TOWBALL	1
18	10mm "D" SHACKLE	2
19	ACRYLIC COMPLIANCE LABEL	1
20	WIRING LOOM	1

1. Remove 2 x torx head screws from tail-light and 1 x torx head screw from bumper. Pull tail-light rearwards to dislodge. Disconnect the attached plug and set aside.

Repeat for opposite side.

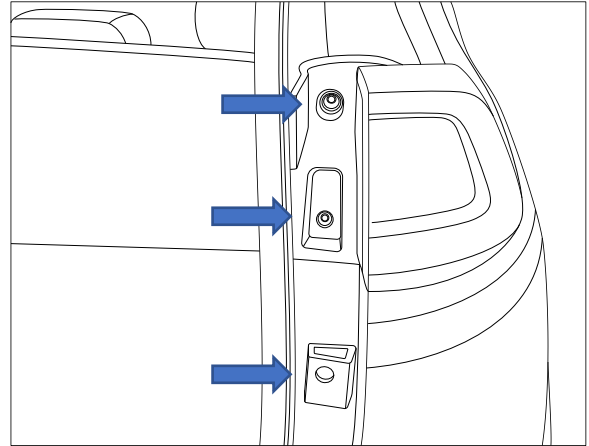

2. Remove 4 x scrivets from wheel arch trim. Carefully peel back trim.

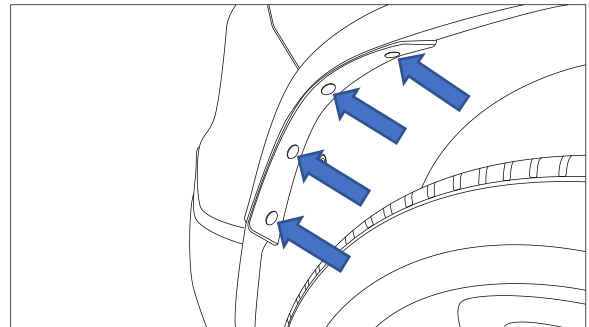

3. Peel back secondary trim located behind trim in Step 2. Remove 1 x torx head screw now exposed.

Repeat Steps 2 and 3 for opposite side.

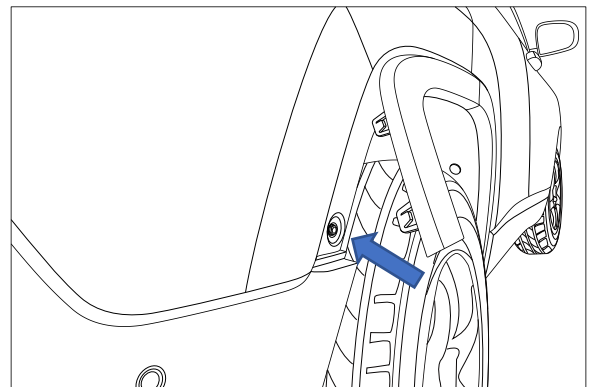

-
4. Remove 2 x torx head screws from within wheel arch.

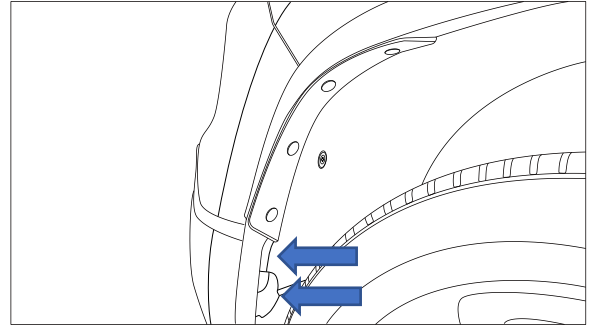

-
5. Drill out 2 x steel rivets from underside of bumper.

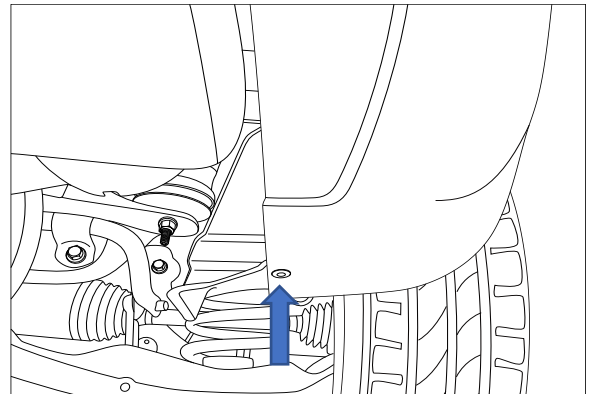

-
6. Remove 4 x hex head screws from underside of bumper.

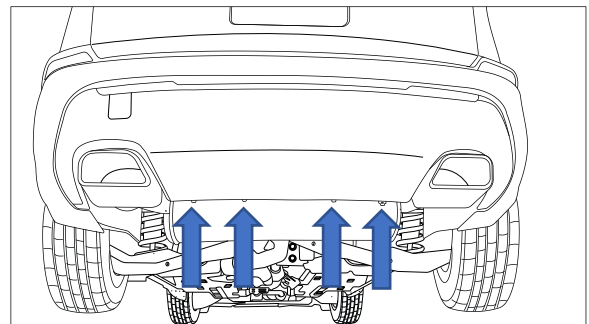

-
- Carefully peel back bumper from corners. Remove bumper ensuring to disconnect wiring on LHS of vehicle. Set bumper safely aside.

-
- Remove 6 x M8 nuts from rear panel connecting impact beam. Discard impact beam and nuts.

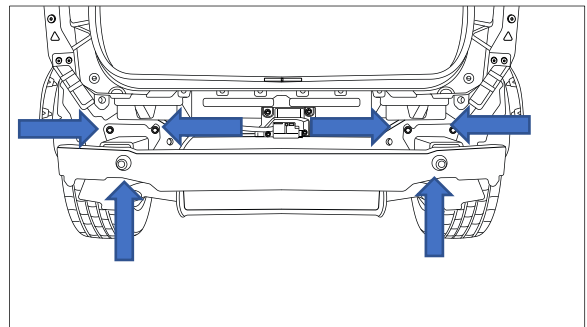

-
- Lift welded assembly of towbar up to rear panel and locate on 6 x M8 studs. Loosely secure welded assembly to studs with 1 x M8 nut complete with 1 x M8 washer per stud.

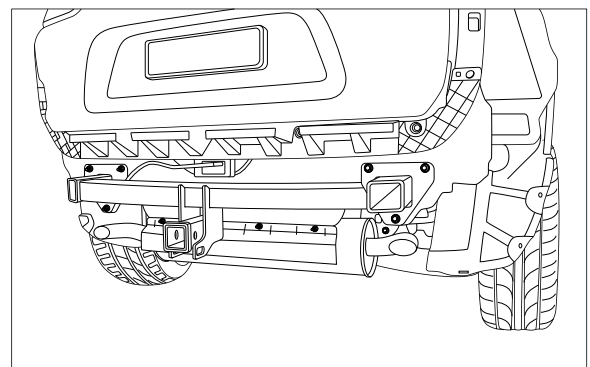

10. Insert side arm into chassis rail and loosely secure from outside chassis rail with 3 x M12 x 35mm bolts complete with 1 x washer per bolt. Refer to exploded diagram on page 3 for correct side arm arrangement.

Repeat for opposite side.

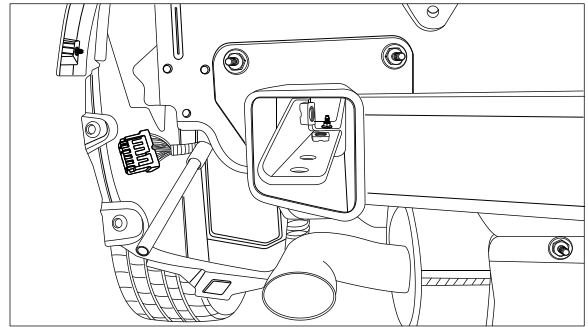

11. Loosely secure side arm to centre welded assembly with 2 x M10 x 30mm bolts complete with 2 x M10 washers and 1 x M10 nut per bolt.

Repeat for opposite side.

Tighten all fasteners to the torques listed below:

M12 x 35mm: 89 N.m

M10 x 30mm: 48 N.m

M8 nuts: 22 N.m

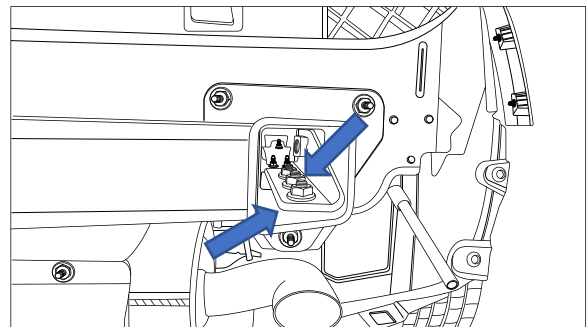

12. Identify the centreline of the bumper. Using the attached bumper cut template (Appendix), mark measure and cut the bumper. Ensure to clean any rough edges after cut.

NOTE: The 170mm measurement starts from the raised edge of the bumper and does not include the bumper tab area.

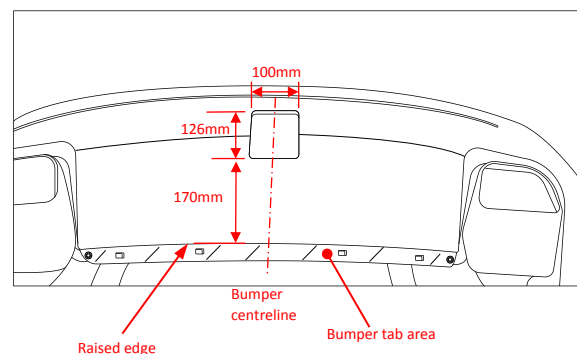

IMPORTANT

Due to possible vehicle variations, always confirm any noted vehicle colour wires with a multi-meter to ensure the correct function is identified before soldering or scotch locking. For vehicle wires denoted with two colours (example; RED/GREEN) the first colour will always be the main wire colour while the second colour is the thinner trace colour on the wire.

-
13. In the Engine Bay, disconnect the vehicle battery negative terminal (1).

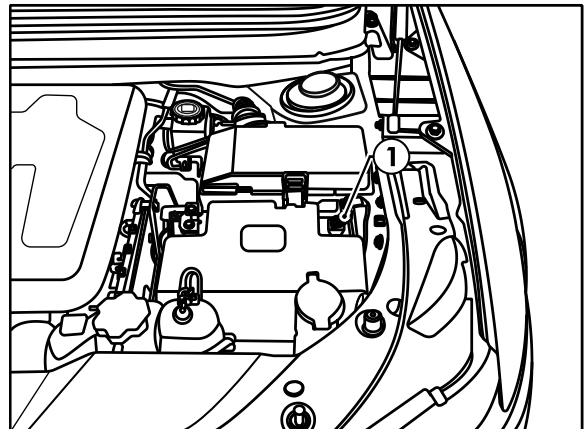

-
14. In the luggage compartment, lift up the floor cover (1) and hang using the hook under the cover (2).

15. Remove the LHS and RHS storage trays (3).

16. Remove the spare wheel (4).

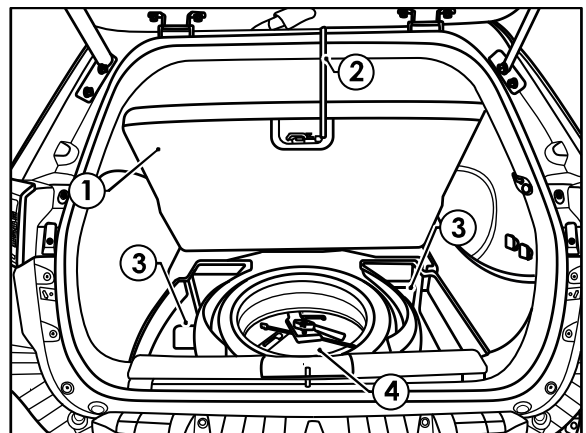

17. Remove the rear scuff trim **(1)** by pulling firmly in the upwards direction.

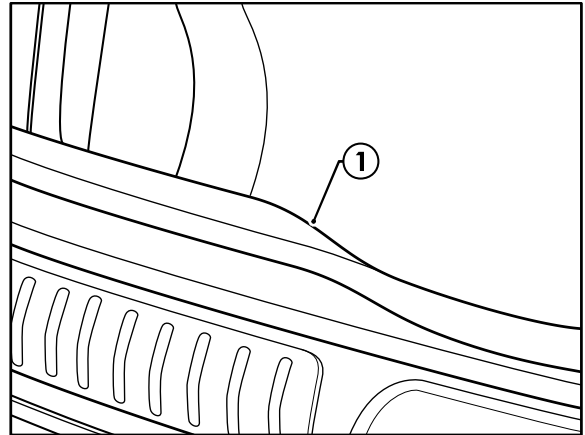

18. Dislodge the RHS D-pillar trim **(1)**.
19. Remove the plastic 6mm Hex screw **(2)** securing the RHS boot trim **(3)**.
20. Remove the plastic cap **(4)** covering the T40 Hex bolt **(5)**.
21. Remove the T40 Hex bolt securing the RHS boot trim.
22. Dislodge the RHS boot trim **(3)**.

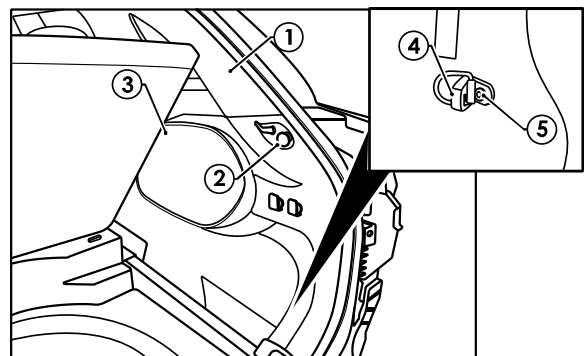

23. At the RHS, connect the tail light connector **(1)** to the mating connector **(2)** near the arched grommet **(3)** on the trailer patch (102183-WL).
24. Unseat the vehicle arched grommet **(4)** and push through to the inside of the vehicle.
25. Feed the white ECU connector **(5)** and ground wire **(6)** through the hole and into the vehicle.
26. Seat the arched grommet on the trailer patch **(3)** into the mating vehicle hole.

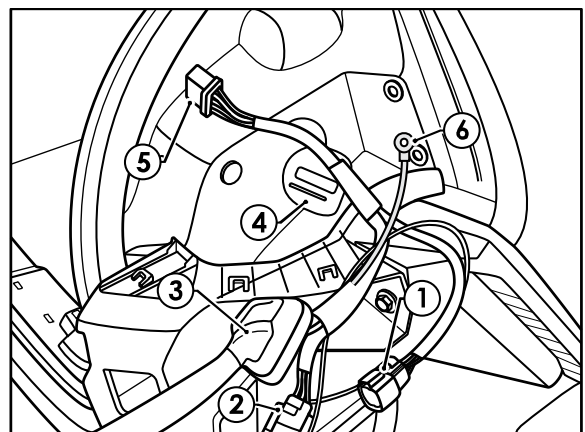

27. Route the trailer patch (1) across to the LHS tail lights (2).
28. Use the supplied Cable Ties (3) to secure the harness to the towbar (4).
29. Patch in the LHS mating connectors in between the vehicle harness and the LHS tail light.

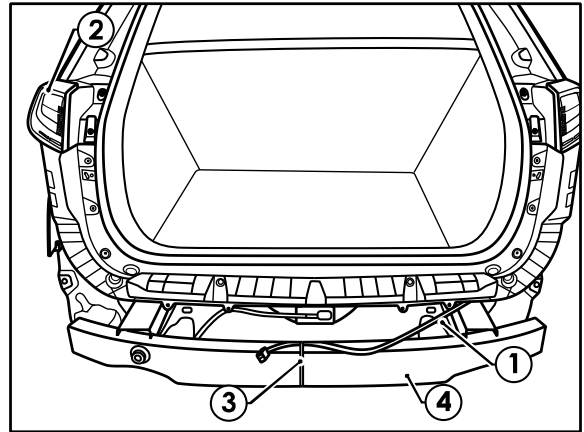

30. Inside the vehicle, locate a suitable area to mount the ECU (1).
31. Using an alcohol wipe, clean the LHS inner sheet metal area and the underside of the ECU (04826) (1). ***ECU upside down**
32. Connect the trailer patch 12-way connector (2) to the ECU.
33. Apply double sided tape to the ECU and secure it to the vehicle sheet metal.
34. Connect the ground wire ring terminal (3) to the vehicle earthing point (4).

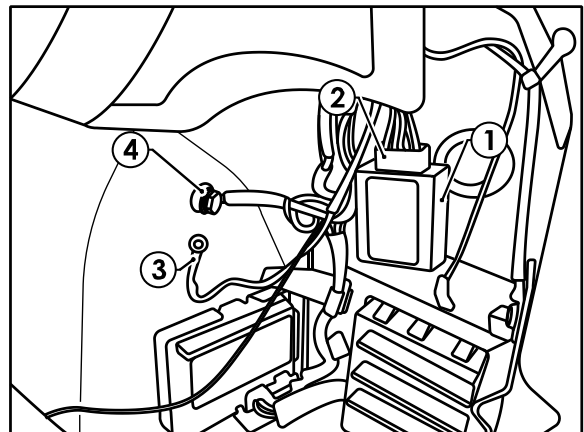

35. Near the towbar, connect the power harness 1-way connector to the mating 1-way connector on the trailer patch.
36. Route the power harness (1) under the vehicle towards the engine bay.
37. Route the power harness ring terminal (2) up towards the vehicle battery and connect to battery positive terminal (3).

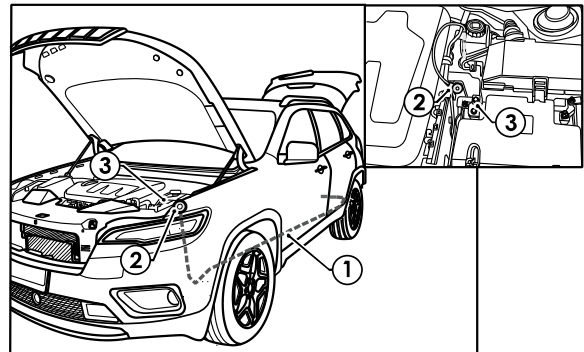

Note: Keep harness routing clear of all sharp edges, moving parts and places of extreme heat.

-
38. With the rear bumper removed, secure tail harness (400mm) to towbar.
 39. Connect the tail harness 8-way connector **(1)** to the trailer patch 8-way mating connector **(2)**.
 40. Apply silicone grease (not supplied) **(3)** to waterproof connector.

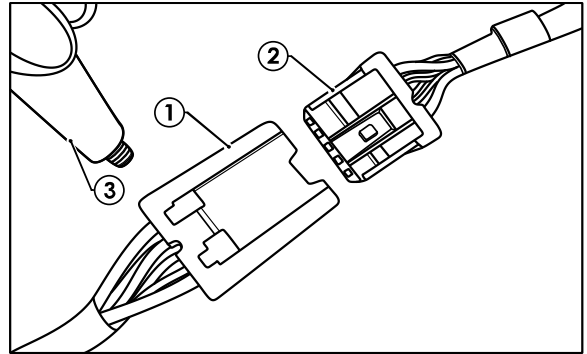

-
41. Test the trailer patch function using a light board or multi-meter.
 42. Re-fit all removed parts and secure all fasteners, ensuring there are no squeaks or rattles.
 43. The RPA function can be disabled via a switch near the hazard switch.
 44. Place the fitting instructions in the glove box after fitment.
 45. Re-fit all removed components following Steps 1-7 in reverse. Use supplied rivets to replace those drilled out in Step 5.

-
46. Mark out and drill 2 x $\varnothing 5$ mm holes 69mm apart on bumper skin to support plug bracket.

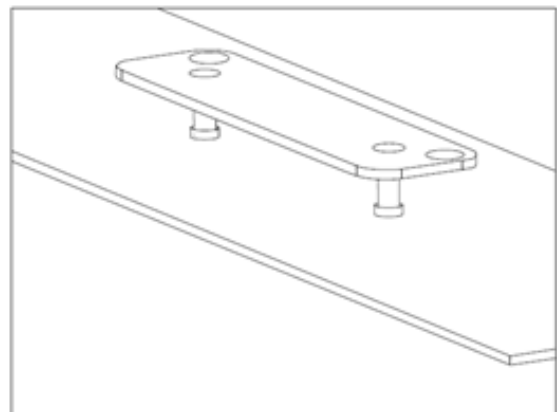



CUSTOMER INFORMATION

PLACE THESE INSTRUCTIONS IN THE
VEHICLE'S GLOVEBOX AFTER INSTALLATION

**THANK YOU FOR PURCHASING TRAILBOSS. WITH CORRECT MAINTENANCE AND CARE
THIS PRODUCT WILL PROVIDE A LIFETIME OF TROUBLE-FREE OPERATION.**

TOWBAR MAINTENANCE AND CARE:

1. Trailboss recommend that the towbar LUG or TBM (Trailer Ball Mount) Pull Pin and R-clip are removed and stored when not in use. Removal of LUG or TBM (Trailer Ball Mount) is advisable when not in use to assist with any of the following.
 - Ensure rear number plate is not obscured.
 - Allow maximum available departure angle and prevent any potential interference.
 - Prevent possible interference with vehicles reverse sensors or camera detecting a tow ball mount as an obstruction during reversing.
 - Removes towball mount as an obstruction for when moving around the rear of the vehicle.
2. Trailboss recommends routine inspection of your towbar to ensure trouble free towing.
 - Bolt security and tension should be regularly inspected and checked for correct tension. Replace any worn or defective parts with suitable grade & class fasteners. Inspection should be requested to coincide with vehicle major services.
3. It is the owner's responsibility to ensure towing and down ball weight capacities of the towing vehicle are not exceeded.
 - Towing and down ball weights allowable may differ according to model variations. Please refer to owner's manual or vehicle dealer to confirm exact rating for your vehicle model variant.
 - It is not uncommon for the vehicle tow rating to differ from the towbar rating. When this occurs, the lesser rating must be adhered to.
 - For vehicles fitted with enhanced vehicle functions that may be altered/changed when towing i.e Trailer sway mitigation, blind spot detection, adaptive cruise control etc. Please consult owner's manual to understand changes enabled when towing and after towing.

WARRANTY INFORMATION:

Trailboss Towbars are covered by a Lifetime Warranty.

Our goods come with guarantees that cannot be excluded under the Australian Consumer Law. You are entitled to a replacement or refund for a major failure and for compensation for any other reasonably foreseeable loss or damage. You are also entitled to have the goods repaired or replaced if the goods fail to be of acceptable quality and the failure does not amount to a major failure.

For further details please contact customer service on 1800 812 017.

PRO SERIES SILENT ANTI-RATTLE HITCH PIN

Your Trailboss towbar is equipped with a Pro Series Silent Anti-Rattle Hitch Pin technology to help reduce towbar tongue rattle in most driving conditions. Please ensure below instructions are understood and routine maintenance is carried out to ensure best towing experience.

Regularly inspect for wear and check the tightness of the Silent Anti-Rattle Hitch Pin. Follow instructions below to re-tighten the nut as necessary when movement and noise in the tow ball mount is noted.

- Before towing, ensure R-Clip is properly installed and hitch pin nut is installed and tensioned. Replacement parts are available from your Pro Series Distributor.

TOWBALL MOUNT REMOVAL/INSTALLATION

STEP 1

Insert Trailer Ball Mount (TBM) (a) into towbar hitchbox (b), aligning hole in TBM shank (c) with hole in hitchbox (d) (Fig. 1)

STEP 2

Insert Silent Anti-Rattle Hitch Pin (e) through hole in hitchbox and hole in TBM shank (g); ensure the locators are inserted into the notches in the hitchbox (Fig. 2)

STEP 3

Screw Silent Anti-Rattle Hitch Pin (f) onto Smart Pin (g); tighten Smart Pin Nut until finger tight, ensuring TBM is restrained from up and down movement.

STEP 4

Tighten Silent Anti-Rattle Hitch Pin Nut by turning nut a further 1/8th of a turn in the clockwise direction using a 24mm spanner (Fig. 4).

STEP 5

Install Silent Anti-Rattle Hitch Pin R-Clip through the hole that provides best clearance or easiest access. (Fig. 5)

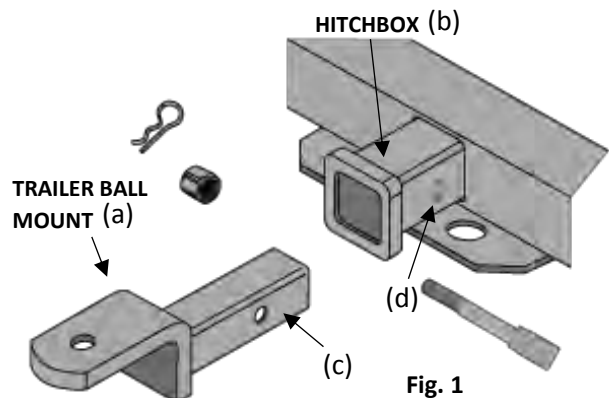

Fig. 1

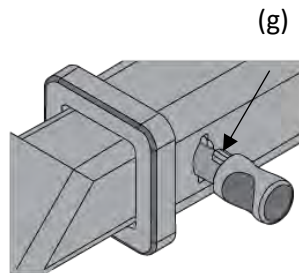

Fig. 2

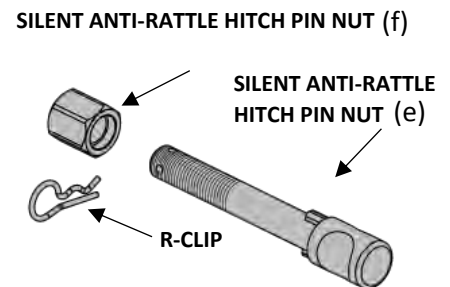

Fig. 3

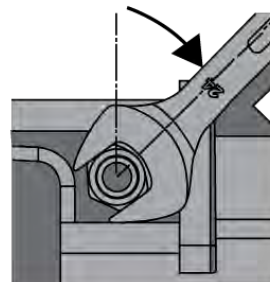

Fig. 4

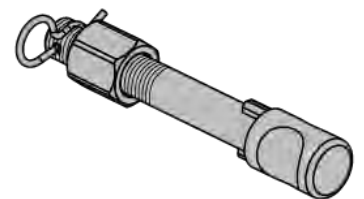

Fig. 5