

**PRODUCT DETAILS:**

---

<b>Part Number:</b>	QTJP21L	<b>Maximum Towing Braked:</b>	2495	kg
<b>ECU Number:</b>	04835	<b>Maximum Towing Unbraked:</b>	750	kg
<b>Tail Harness Length Required:</b>	1200 mm.	<b>Maximum Static Ball Load:</b>	250	kg
<b>TBM/Lug Part Number:</b>	21171			

---

**FITTING DETAILS:**

---

<b>Towbar Installation Time:</b>	60 Mins.	<b>RPA Disable/Other:</b>	YES
<b>Total Installation Time:</b>	90 Mins.		
<b>Bumper Cut Required:</b>	Yes		

---

**Note:**

- RPA Disable - Switch on switch panel near infotainment screen
- Electric Brake Input Location: Near Blue Connector

### TRAILBOSS RECOMMENDS THAT INSTRUCTIONS ARE READ AND UNDERSTOOD COMPLETELY PRIOR TO FITMENT.

#### BEFORE YOU START:

Check all hardware items have been included refer to assembly diagram.  
Please ensure this towbar is only fitted to vehicle models as per Trailboss application guide.

#### Bumper Cuts

Vehicle and bumper variations can and do occur during vehicle manufacture after initial towbar design. Fitment of towbar to vehicle and accuracy of bumper cut must be assessed prior to any bumper modifications made. Incorrect bumper cuts are not covered under Trailboss warranty.

**NOTE: Bumper cuts need to be approached with care, refer to notes below.**

- Bumper centreline – where the centreline of the bumper needs to be determined, the installer must assess centre point by measurement of bumper width or determining two symmetrical reference points to give centreline.
- Bumper edge – To assist with accurate bumper cut measurement, reference to the start of the bumper edge is now being commonly used.
  - Measure from bottom edge along bumper and around corner to the 70 mm point (Figure 1).
  - Do not measure from visible bumper front of corner, upwards (Figure 2).

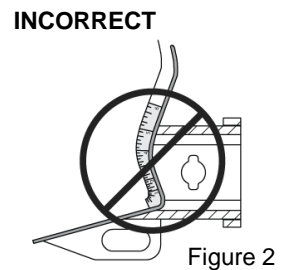
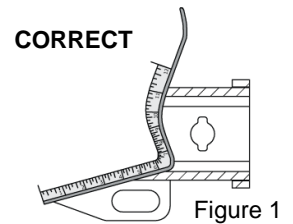

#### Drilling

- For any required drilling during installation, ensure that the area is clear of fuel, electrical & other components that may be damaged.
- All holes drilled into metal body panels shall have all burrs & swarf removed then coated with a suitable rust preventative paint.

#### Bolts/Fasteners

- Ensure that all hardware is fastened to correct torque as specified in this fitting instruction.
- All fasteners supplied with this product are used to achieve a specified clamp loading. If replacement is required ensure that fasteners of the same grade and class are used.

**NOTE: Achieving correct torque is critical to proper installation and responsibility of the installer. Towbar failures attributed to tension issues from over tightening or under tightening are not covered by Trailboss warranty.**

#### Product Labels

- a. Towbar load rating sticker provided with this product shall be conspicuously located on inside rear end of the driver's door.

#### WARNING:

**Do not, drill, cut, weld or otherwise modify the towbar.**

**FOR TOWING PURPOSES ONLY - This towbar is designed and tested by Trailboss to adhere to ADR 62/02 which provides only for the expected load demands of towing.**

### **i** TOWBAR ASSEMBLY DIAGRAM

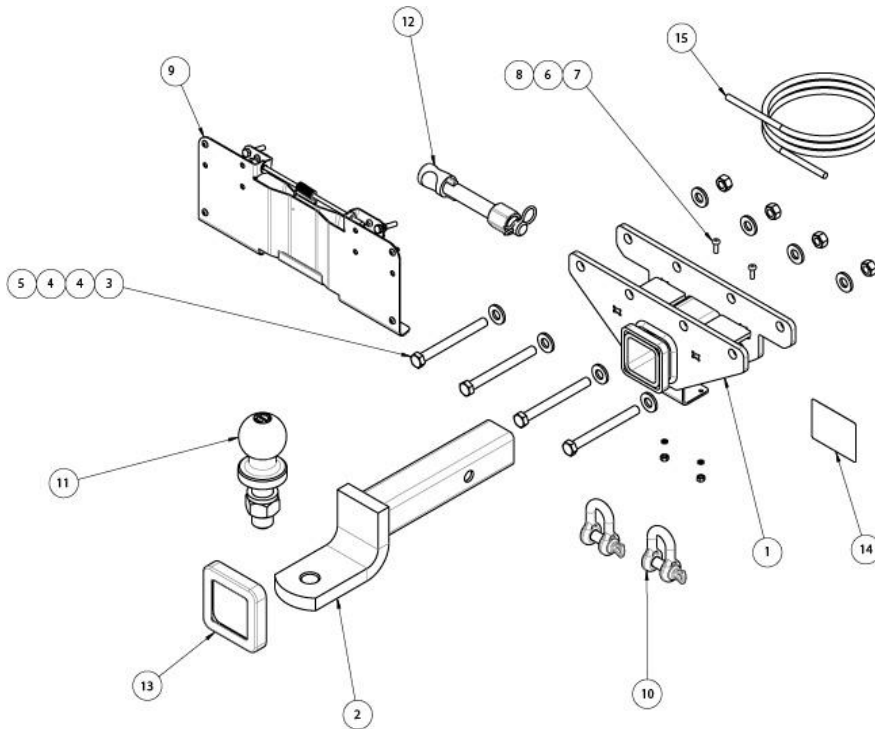

ITEM	DESCRIPTION	QTY
1	JEEP WRANGLER JL WELDED ASSY	1
2	TRAILER BALL MOUNT	1
3	BOLT HEX HD M12x120x1.25P	4
4	WASHER PLAIN 1/2x1-1/8x16	8
5	NUT HEX M12x1.25P	4
6	WASHER SPRING 3/16x1-1/8x3/64	2
7	SCREW PAN HD 3/16x5/8 UNC 24TPI	2
8	NUT HEX 3/16 UNC 24 TPI	2
9	NUMBER PLATE BRACKET	1
10	D" SHACKLE 10mm "	2
11	TOWBALL 50mm	1
12	SILENT HITCH PIN – SILVER	1
13	HITCH BOX COLLAR COVER	1
14	ACRYLIC COMPLIANCE LABEL	1
15	WIRING LOOM	1

1. Remove 3 x Hex head screws from inside the wheel arch and remove plastic cover.

Repeat for other side.

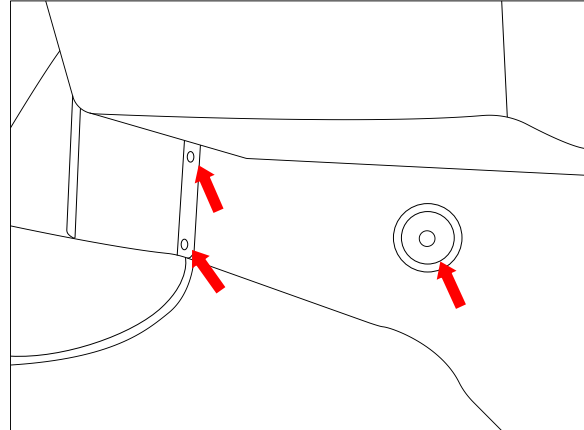

2. On the LH side, dislodge the wiring loom connector from the exposed rear panel and disconnect the connector.

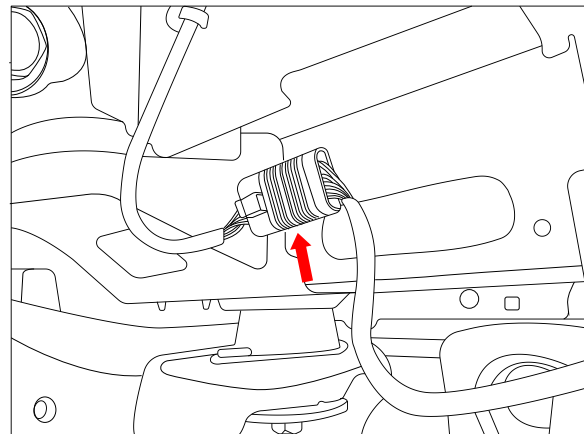

3. Remove 2 x Bolts securing the bumper to the support bracket.

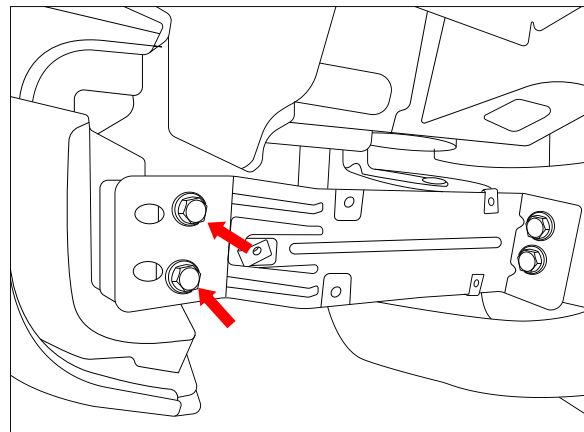

4. From under the vehicle, remove 2 x bolts securing the centre of the bumper to the chassis rear crossmember.

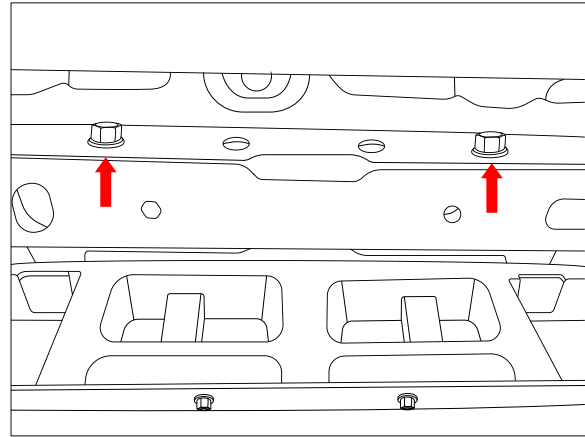

5. From under vehicle, remove 2 x nuts securing the bumper to the vehicle rear panel.

Repeat for other side.

6. Remove bumper from vehicle.

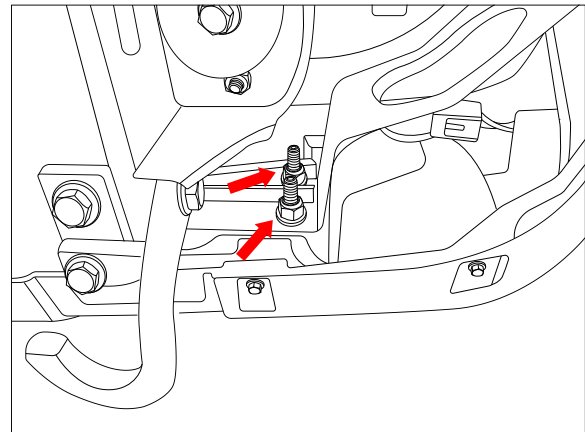

7. Lift towbar to the chassis' rear crossmember and secure with 4 x M12 bolts complete with 2 x washers and 1 x nut per bolt.

**Torque bolts to 125Nm**

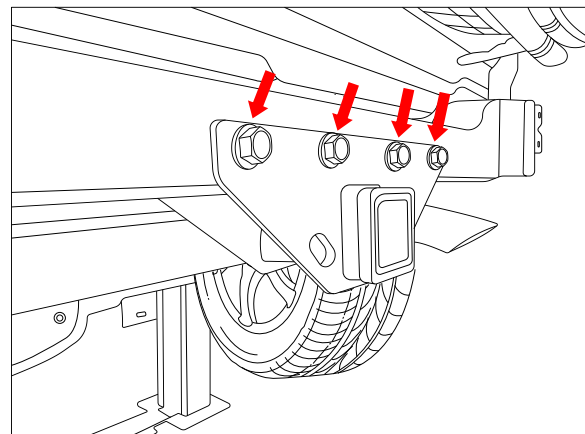

8. On the bumper, remove and discard the mounting bracket secured with 2 x hex screws.

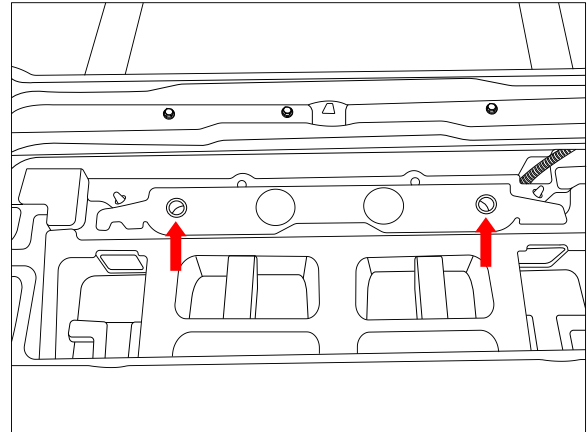

9. For bumper cut.  
Determine the centre of the bumper, measure, mark and cut out a hole 85mm x 85mm as depicted in the sketch.  
The cut hole requires to be cut through the bumper skin and inside panel.

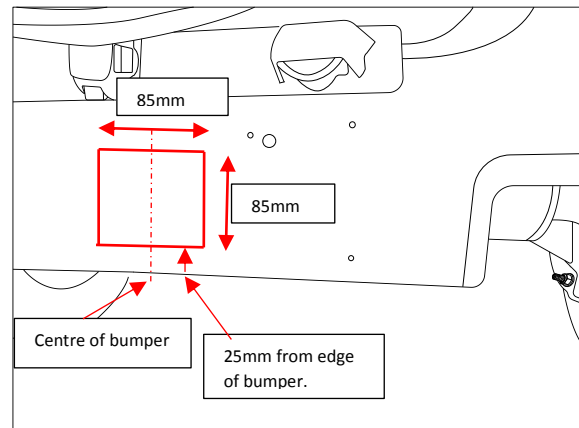

10. For the Number plate kit fitment.  
Align the centre of the hinge plate to the centre of the bumper and position the bottom of the hinge plate 102 mm above the bottom edge of the bumper as indicated.  
Refer to the Number plate kit fitting instruction (8317) for the fitment of the plate and assembly of the kit.

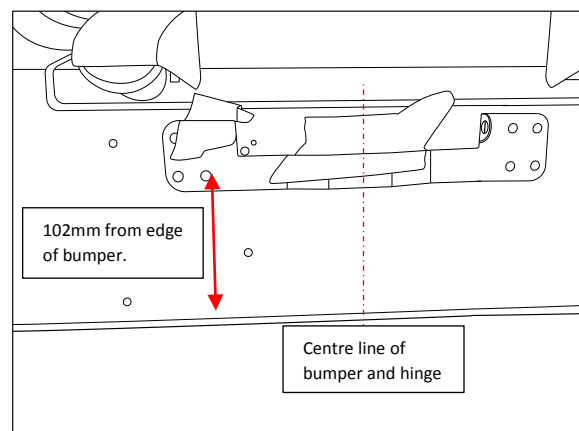

### IMPORTANT

Due to possible vehicle variations, always confirm any noted vehicle colour wires with a multi-meter to ensure the correct function is identified before soldering or scotch locking. For vehicle wires denoted with two colours (example; RED/GREEN) the first colour will always be the main wire colour while the second colour is the thinner trace colour on the wire.

11. In the Engine Bay, disconnect the vehicle battery negative terminal (1).

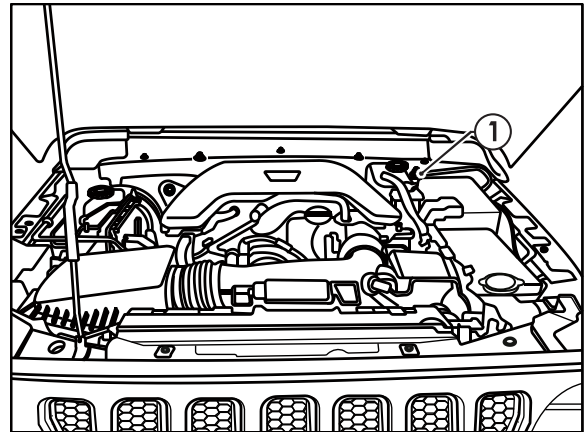

12. In the boot on the right hand side, locate the cap (1) covering the tail light screw.  
13. Using a trim removal tool remove the cap.  
14. Under the previously removed cap, remove the white 10mm plastic screw securing the RHS tail lamp.

**Repeat for LHS.**

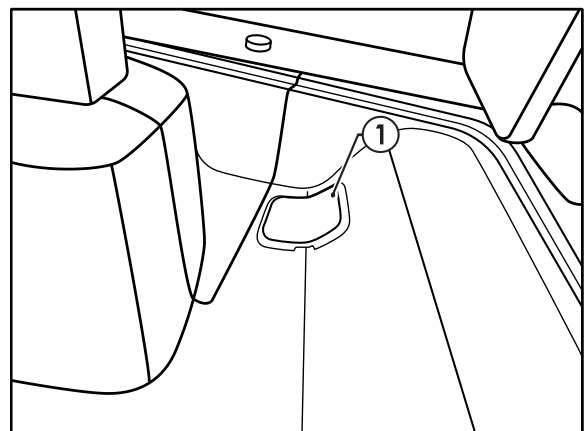

15. Dislodge the rear right tail light (1) by pulling firmly towards the rear of the vehicle.
16. Disconnect the tail lamp connector (2) from the vehicle connector (3), by first pulling out the red connector position assurance tab (4).

**Repeat for LHS.**

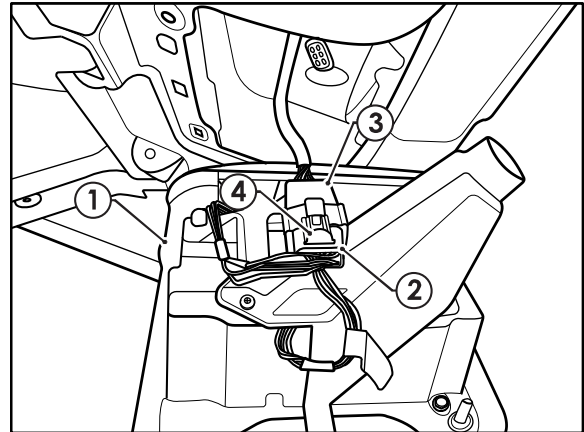

17. From under the vehicle, route the trailer patch (102213-WL) RHS patch up to the vehicle RHS tail lamp. Ensure to route the patch through the small hole (1) rather than the larger hole for the rear door hinge (2).
18. Patch the mating connectors on the trailer patch (3) in between the vehicle connector (4) and the tail light.

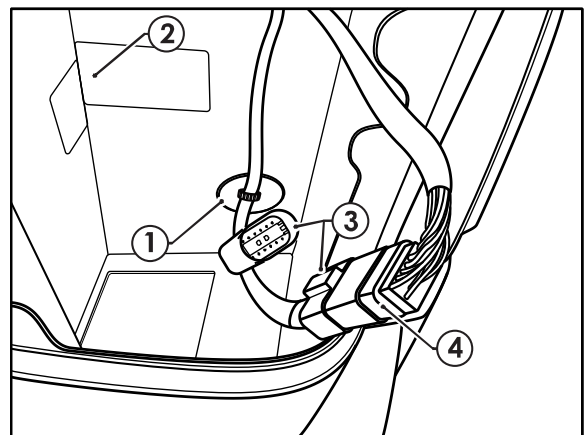

19. Identify a suitable area under the RHS to mount the waterproof ECU (04835) (1).
20. Connect the trailer patch 24-way connector (2) to the ECU (1).
21. Using Cable Ties, secure the ECU (1) to the chassis sheet metal high on the RHS underbody.

**Note: Mount the ECU, ensuring the connector is orientated downwards.**

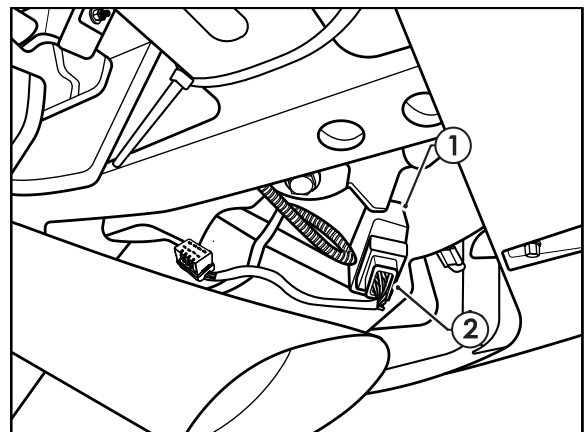



22. Under the vehicle, route the trailer patch (1) across to the LHS.
23. Use the supplied Cable Ties (2) to secure the harness as required.

**Note: Keep harness routing clear of all sharp edges, moving parts and places of extreme heat.**

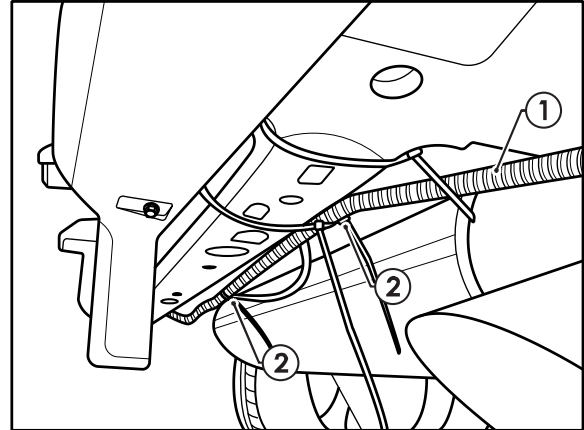

24. Under the vehicle, route the trailer patch (1) LHS patch up to the vehicle LHS tail lamp.
25. Patch the mating connectors on the LHS patch (1) in between the vehicle connector (2) and the tail light.

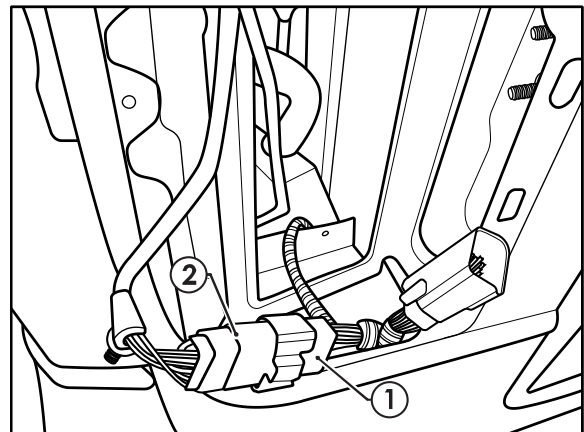

26. Route the power and ground wire ring terminals (1) along the underbody above the suspension (2).
27. Cable Tie the harness (1) away from exhaust and suspension components.

**Note: Keep harness routing clear of all sharp edges, moving parts and places of extreme heat.**

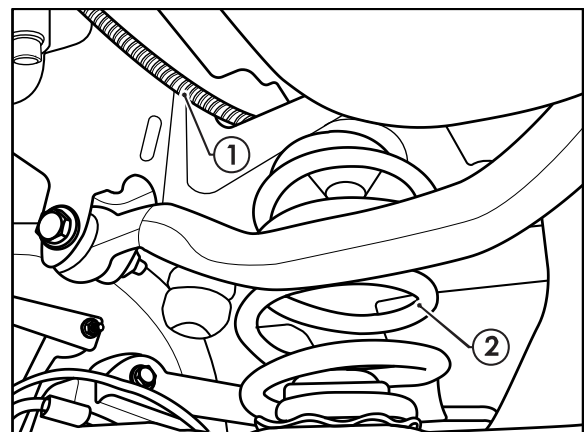

28. Continue routing the power and ground wire ring terminals (1) along the underbody, above the chassis rail (2).
29. Cable Tie the harness (1) away from exhaust and suspension components.

**Note: Keep harness routing clear of all sharp edges, moving parts and places of extreme heat.**

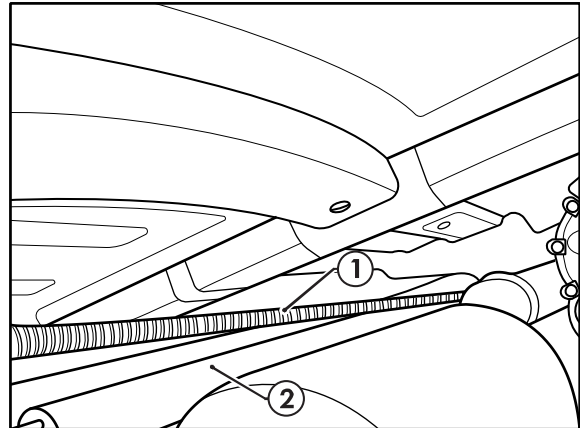

30. Route the power and ground wire ring terminals up in the engine bay towards the vehicle battery.
31. Secure the fuse and orange wire ring terminal to the vehicle battery positive (1).
32. Secure the white wire ring terminal to the vehicle battery negative (2).

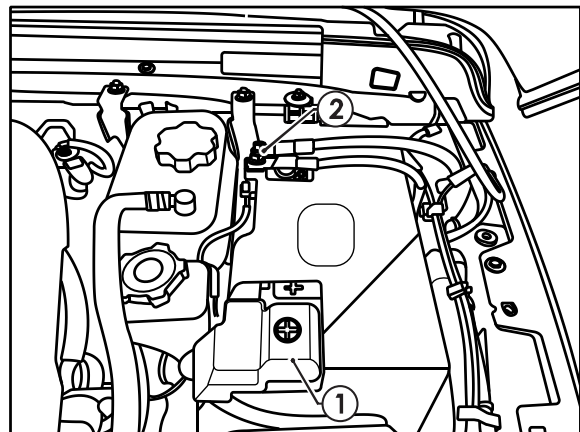

33. With the rear bumper removed, secure tail harness (Tail Length 1200mm) to towbar.
34. Route harness up towards the blue connector on the RHS.

**Note: Keep harness routing clear of all sharp edges, moving parts and places of extreme heat.**

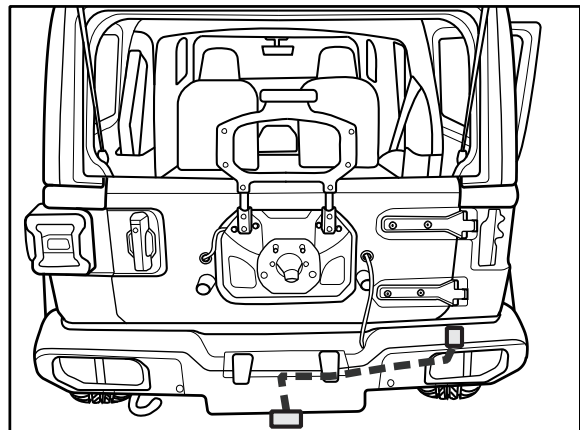

- 
35. Connect the tail harness 8-way connector (1) to the trailer patch mating 8-way connector (2).
  36. Apply silicone grease (not supplied) (3) to waterproof connector.

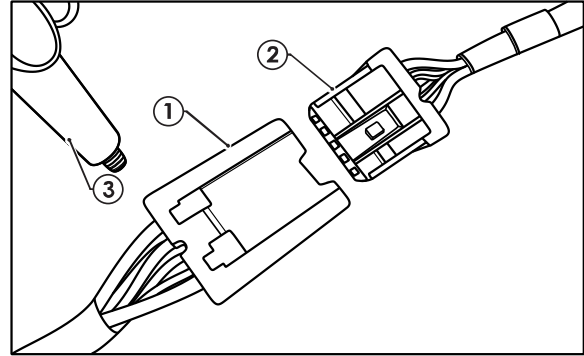

- 
37. Secure all harness using supplied cable ties.
  38. Test the trailer patch function using a light board or multi-meter.
  39. Re-fit all removed parts and secure all fasteners, ensuring there are no squeaks or rattles.
  40. The RPA function can be disabled via a switch on the switch panel near the infotainment screen.
  41. Place the fitting instructions in the glove box after fitment.
-



## CUSTOMER INFORMATION

PLACE THESE INSTRUCTIONS IN THE  
VEHICLE'S GLOVEBOX AFTER INSTALLATION

**THANK YOU FOR PURCHASING TRAILBOSS. WITH CORRECT MAINTENANCE AND CARE  
THIS PRODUCT WILL PROVIDE A LIFETIME OF TROUBLE-FREE OPERATION.**

### TOWBAR MAINTENANCE AND CARE:

1. Trailboss recommend that the towbar LUG or TBM (Trailer Ball Mount) Pull Pin and R-clip are removed and stored when not in use. Removal of LUG or TBM (Trailer Ball Mount) is advisable when not in use to assist with any of the following.
  - Ensure rear number plate is not obscured.
  - Allow maximum available departure angle and prevent any potential interference.
  - Prevent possible interference with vehicles reverse sensors or camera detecting a tow ball mount as an obstruction during reversing.
  - Removes towball mount as an obstruction for when moving around the rear of the vehicle.
2. Trailboss recommends routine inspection of your towbar to ensure trouble free towing.
  - Bolt security and tension should be regularly inspected and checked for correct tension. Replace any worn or defective parts with suitable grade & class fasteners. Inspection should be requested to coincide with vehicle major services.
3. It is the owner's responsibility to ensure towing and down ball weight capacities of the towing vehicle are not exceeded.
  - Towing and down ball weights allowable may differ according to model variations. Please refer to owner's manual or vehicle dealer to confirm exact rating for your vehicle model variant.
  - It is not uncommon for the vehicle tow rating to differ from the towbar rating. When this occurs, the lesser rating must be adhered to.
  - For vehicles fitted with enhanced vehicle functions that may be altered/changed when towing i.e Trailer sway mitigation, blind spot detection, adaptive cruise control etc. Please consult owner's manual to understand changes enabled when towing and after towing.

### WARRANTY INFORMATION:

Trailboss Towbars are covered by a Lifetime Warranty.

Our goods come with guarantees that cannot be excluded under the Australian Consumer Law. You are entitled to a replacement or refund for a major failure and for compensation for any other reasonably foreseeable loss or damage. You are also entitled to have the goods repaired or replaced if the goods fail to be of acceptable quality and the failure does not amount to a major failure.

For further details please contact customer service on 1800 812 017.

## PRO SERIES SILENT ANTI-RATTLE HITCH PIN

Your Trailboss towbar is equipped with a Pro Series Silent Anti-Rattle Hitch Pin technology to help reduce towbar tongue rattle in most driving conditions. Please ensure below instructions are understood and routine maintenance is carried out to ensure best towing experience.

Regularly inspect for wear and check the tightness of the Silent Anti-Rattle Hitch Pin. Follow instructions below to re-tighten the nut as necessary when movement and noise in the tow ball mount is noted.

- Before towing, ensure R-Clip is properly installed and hitch pin nut is installed and tensioned. Replacement parts are available from your Pro Series Distributor.

## TOWBALL MOUNT REMOVAL/INSTALLATION

### STEP 1

Insert Trailer Ball Mount (TBM) (a) into towbar hitchbox (b), aligning hole in TBM shank (c) with hole in hitchbox (d) (Fig. 1)

### STEP 2

Insert Silent Anti-Rattle Hitch Pin (e) through hole in hitchbox and hole in TBM shank (g); ensure the locators are inserted into the notches in the hitchbox (Fig. 2)

### STEP 3

Screw Silent Anti-Rattle Hitch Pin (f) onto Smart Pin (g); tighten Smart Pin Nut until finger tight, ensuring TBM is restrained from up and down movement.

### STEP 4

Tighten Silent Anti-Rattle Hitch Pin Nut by turning nut a further 1/8th of a turn in the clockwise direction using a 24mm spanner (Fig. 4).

### STEP 5

Install Silent Anti-Rattle Hitch Pin R-Clip through the hole that provides best clearance or easiest access. (Fig. 5)

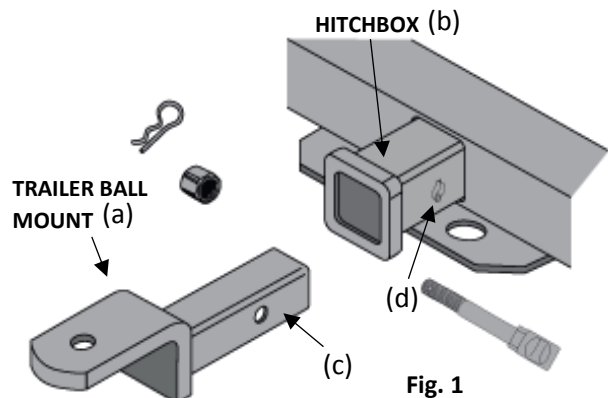

Fig. 1

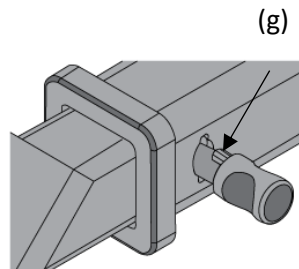

Fig. 2

SILENT ANTI-RATTLE HITCH PIN NUT (f)

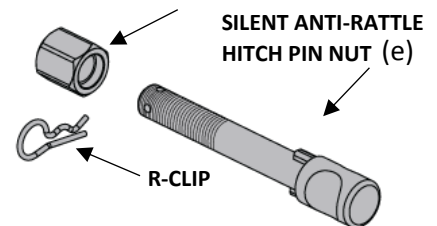

Fig. 3

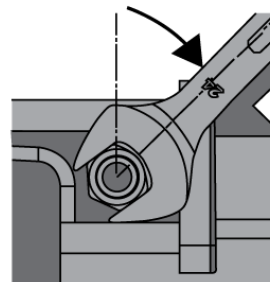

Fig. 4

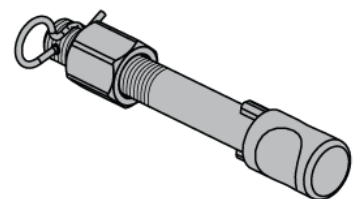

Fig. 5