



Towbar Fitting Instructions
To Suit CHRYSLER JEEP GRAND CHEROKEE V8 7/99-ON
Part Number QTJP5
Rating 3039Kg

1. Ensure all hardware items have been included.
2. Remove shipping hook and discard.
3. Remove and retain support braces were fitted.
4. From under vehicle locate and remove four plastic buttons connecting bumper bar to fuel tank guard, retain buttons to be reused.
5. Carefully pull away lower edge of bumper to locate centre inprint mark. Now transfer this on the outer face of bumper and mark and cut out (see diagram).
6. Remove two rear most bolts on driver=s side supporting tank guard and discard.
7. Lift towbar so as holes in side arms align with chassis holes and fuel tank guard holes, and into captive nuts.
8. Insert M12x45 bolts and spring washers supplied to support towbar starting with centre holes on each side.
9. Insert loose plate to rear most holes only once all bolts have been fitted.
10. Refit support braces to original position on fuel tank guard inner, Using studs in towbar and nuts supplied for outer mounting.
11. Tighten all bolts to torque listing below.
12. Refit plastic buttons (reversal to instruction 3).

RECOMMENDED ASSEMBLY TORQUE LISTING

<u>Diameter</u>	<u>Grade 8.8 Bolt</u>
	Nm
M6	9.5
M8	21.7
M10	43.4
M12	77.3
M14	121.0
M16	189.8

Towbar Fitting Instructions
To Suit CHRYSLER JEEP GRAND CHEROKEE V8 7/99-ON
Part Number QTJP5
Rating 3039Kg

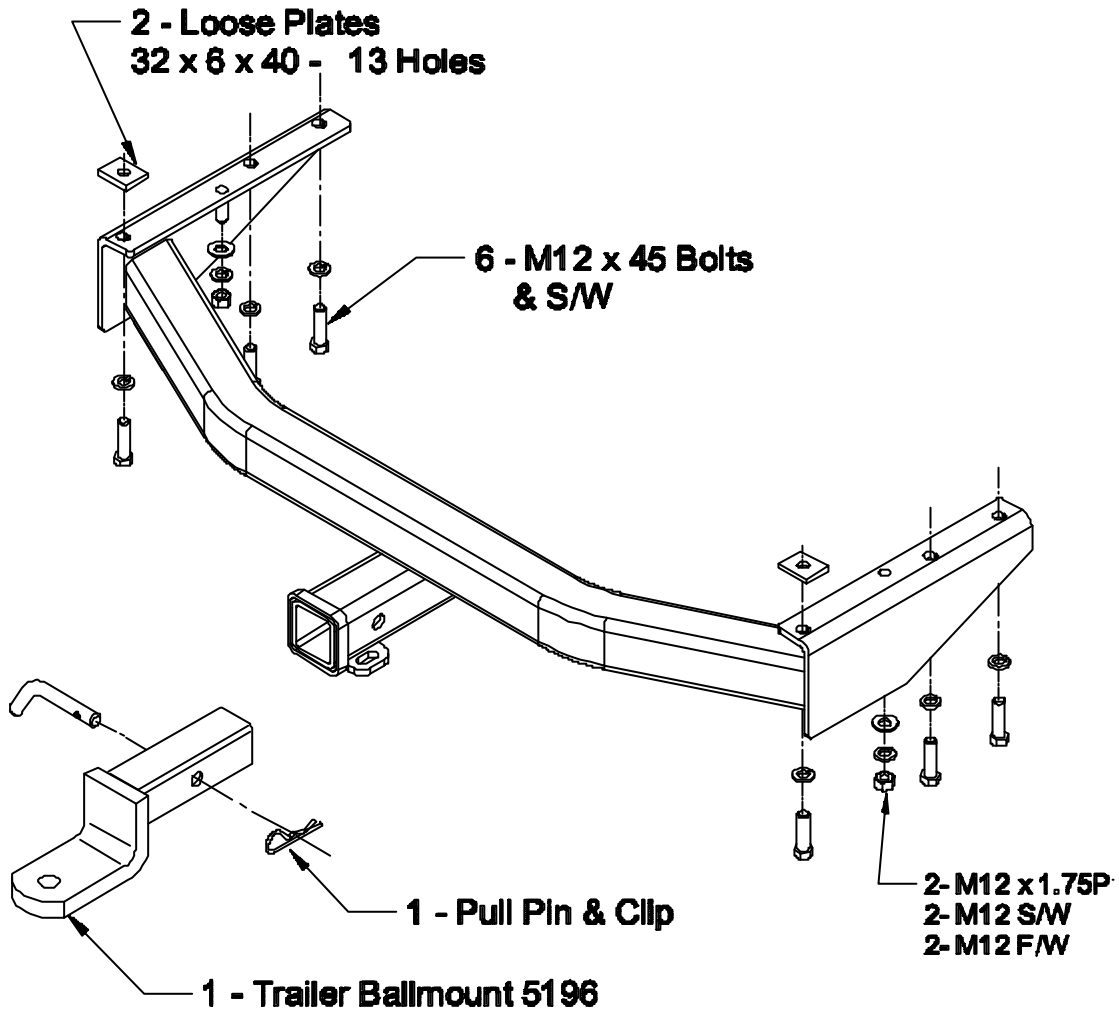



Towbar Fitting Instructions
To Suit CHRYSLER JEEP GRAND CHEROKEE V8 7/99-ON
Part Number QTJP5
Rating 3039Kg

