

PRODUCT DETAILS:

Part Number:	QTKM29L	Maximum Towing Braked:	1650	kg
ECU Number:	WLE70022	Maximum Towing Unbraked:	750	kg
Tail Harness Length Required:	1200 mm	Maximum Static Ball Load:	165	kg
TBM/Lug Part Number:	21325			

FITTING DETAILS:

Towbar Installation Time:	90 Mins.	RPA Disable/Other:	YES
Total Installation Time:	120 Mins.		
Bumper Cut Required:	Yes		

Note:

- RPA Disable use 04936 tail.

TRAILBOSS RECOMMENDS THAT INSTRUCTIONS ARE READ AND UNDERSTOOD COMPLETELY PRIOR TO FITMENT.

BEFORE YOU START:

Check all hardware items have been included refer to assembly diagram.
Please ensure this towbar is only fitted to vehicle models as per Trailboss application guide.

Bumper Cuts

Vehicle and bumper variations can and do occur during vehicle manufacture after initial towbar design. Fitment of towbar to vehicle and accuracy of bumper cut must be assessed prior to any bumper modifications made. Incorrect bumper cuts are not covered under Trailboss warranty.

NOTE: Bumper cuts need to be approached with care, refer to notes below.

- Bumper centreline – where the centreline of the bumper needs to be determined, the installer must assess centre point by measurement of bumper width or determining two symmetrical reference points to give centreline.
- Bumper edge – To assist with accurate bumper cut measurement, reference to the start of the bumper edge is now being commonly used.
 - Measure from bottom edge along bumper and around corner to the 70 mm point (Figure 1).
 - Do not measure from visible bumper front of corner, upwards (Figure 2).

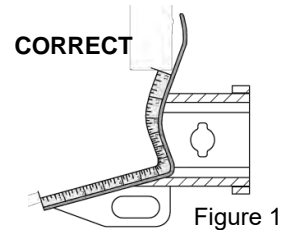

Figure 1

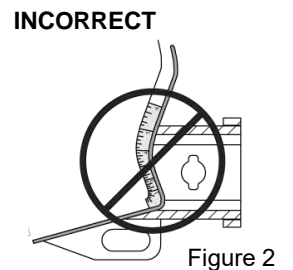

Figure 2

Drilling

- For any required drilling during installation, ensure that the area is clear of fuel, electrical & other components that may be damaged.
- All holes drilled into metal body panels shall have all burrs & swarf removed then coated with a suitable rust preventative paint.

Bolts/Fasteners

- Ensure that all hardware is fastened to correct torque as specified in this fitting instruction.
- All fasteners supplied with this product are used to achieve a specified clamp loading. If replacement is required ensure that fasteners of the same grade and class are used.

NOTE: Achieving correct torque is critical to proper installation and responsibility of the installer. Towbar failures attributed to tension issues from over tightening or under tightening are not covered by Trailboss warranty.

Product Labels

- a. Towbar load rating sticker provided with this product shall be conspicuously located on inside rear end of the driver's door.

WARNING:

Do not, drill, cut, weld or otherwise modify the towbar.

FOR TOWING PURPOSES ONLY - This towbar is designed and tested by Trailboss to adhere to ADR 62/02 which provides only for the expected load demands of towing.

i TOWBAR ASSEMBLY DIAGRAM

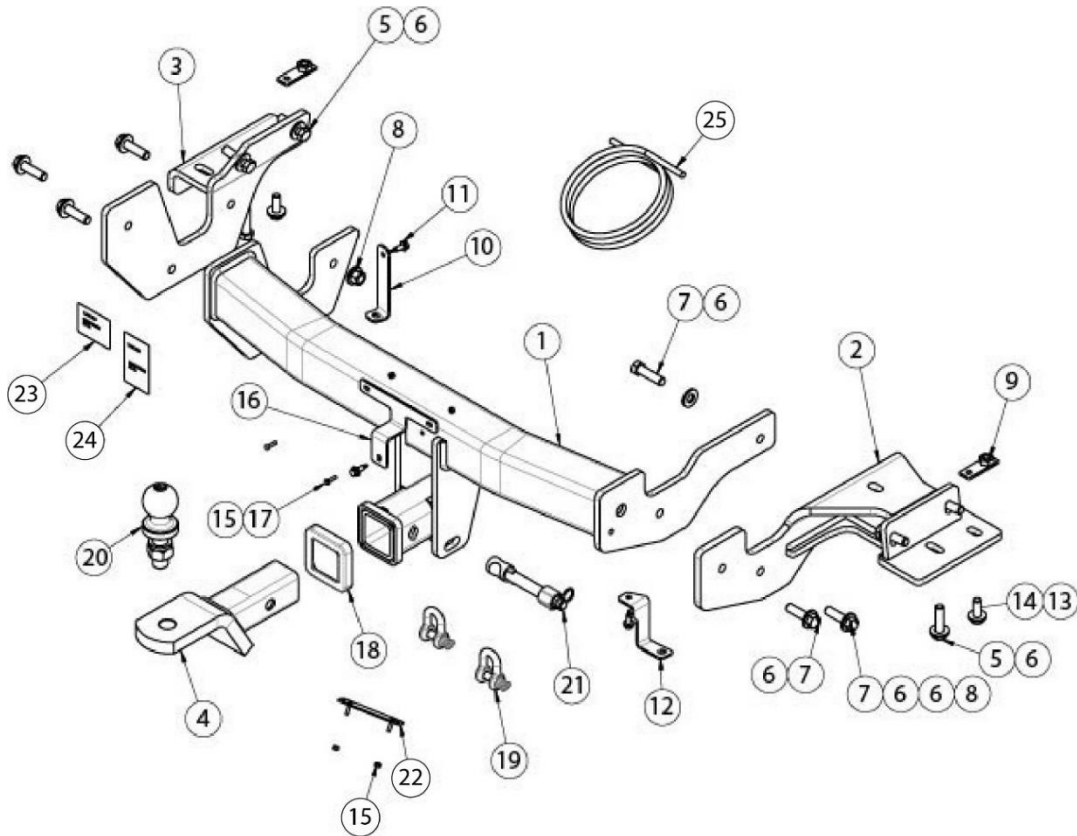

ITEM	DESCRIPTION	QTY
1	KIA SORENTO WELDED ASSY	1
2	SIDE ARM – RHS	1
3	SIDE ARM – LHS	1
4	TRAILER BALL MOUNT	1
5	BOLT HEX HD M12x45x1.25P	6
6	WASHER PLAIN 1/2"	15
7	BOLT HEX HD M12x45x1.75P	6
8	NUT HEX HD M12x1.75P	3
9	NUT PLATE	2
10	BUMPER TAB – LHS	1
11	TEK SCREW 14-20 HEX HD 22mm	3
12	BUMPER TAB RHS	1
13	WASHER PLAIN M10x25x3	2

ITEM	DESCRIPTION	QTY
14	BOLT HEX HD M10x30x1.5P	2
15	NUT NYLOC HEX HD M4x0.7P	4
16	SENSOR BRACKET	1
17	SCREW PAN HD M4x16x0.7P	2
18	HITCH BOX COLLAR COVER	1
19	"D" SHACKLE 10mm	2
20	TOWBALL 50mm	1
21	SMART PIN SILVER	1
22	PLUG BRACKET	1
23	COMPLIANCE LABEL	1
24	LOAD RATING LABEL	1
25	WIRE LOOM	1

1. Open the tailgate.
Using the wheel tool kit and lower the spare wheel.

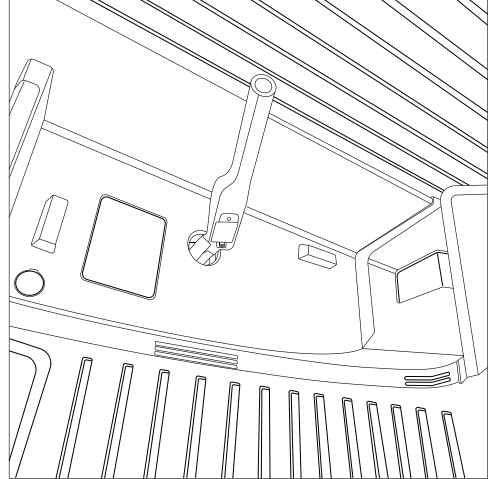

2. Open the 2x plastic caps, unscrew 2x screws.
Repeat for the other side.

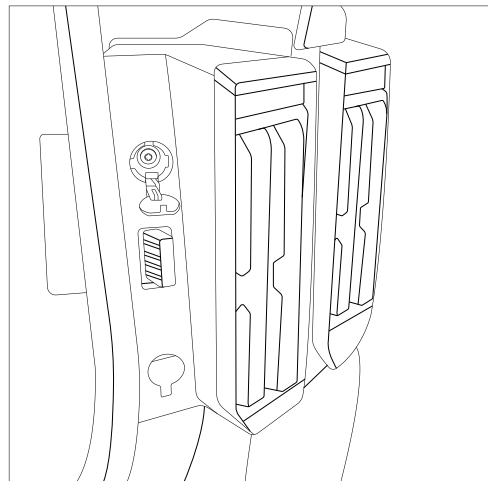

3. Pull rear ward, disconnect and remove the taillight.
Remove 2x scrivet clips.
Repeat for the other side.

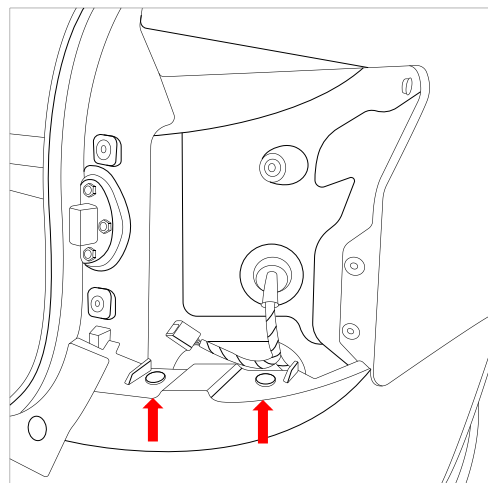

-
4. Remove 3x screws and 2x scrivet clips.

Repeat for the other side.

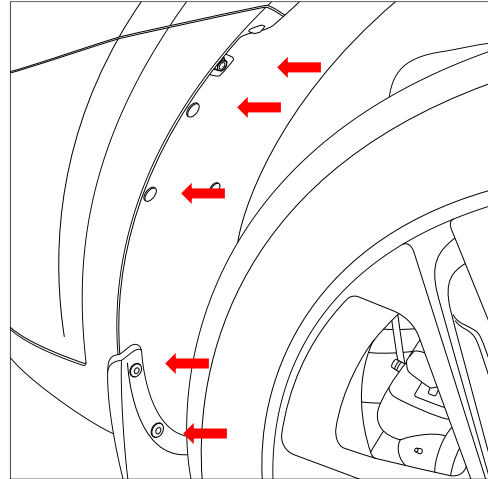

-
5. On the LHS below the wheel arch.

Remove 5x scrivet clips.

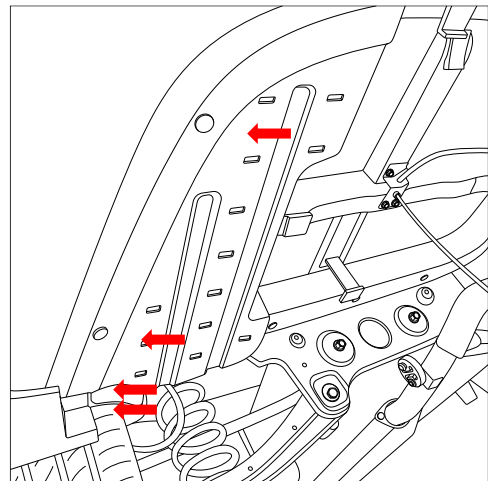

-
6. On the RHS below the wheel arch.

Remove 3x scrivet clips.

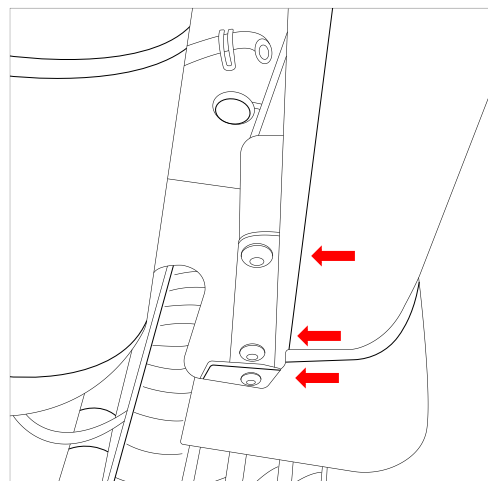

-
7. From the underside of the vehicle, remove 2x bolts from the impact beam which attached to the bumper.

Repeat for the other side.

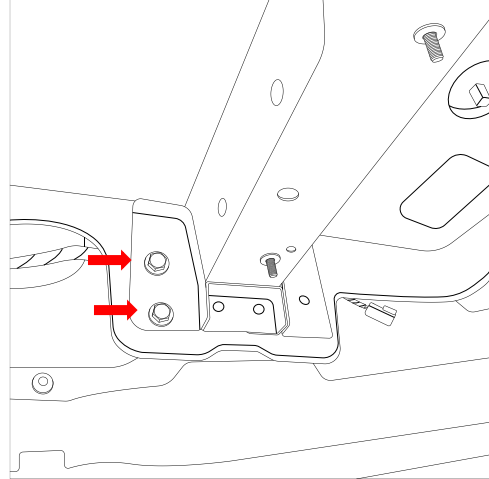

-
8. Unclip the bumper.

Note:
Disconnect the bumper sensor wire loom located on LHS of the bumper.

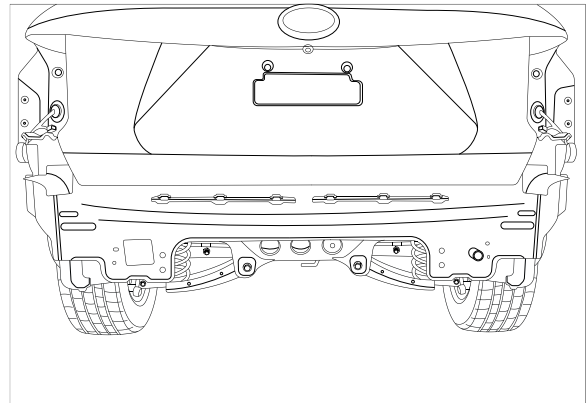

-
9. Remove the exhaust muffler by unscrew 2x bolts and slide off 3x rubber muffler hangers.

Note:
Leave the rubber hangers on the vehicle.

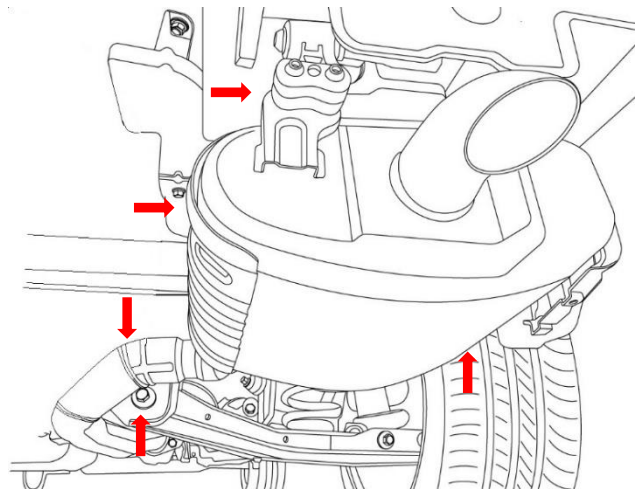

10. Remove the rubber grommet on the chassis.
Insert the nut plate into the hole.

Repeat for the other side.

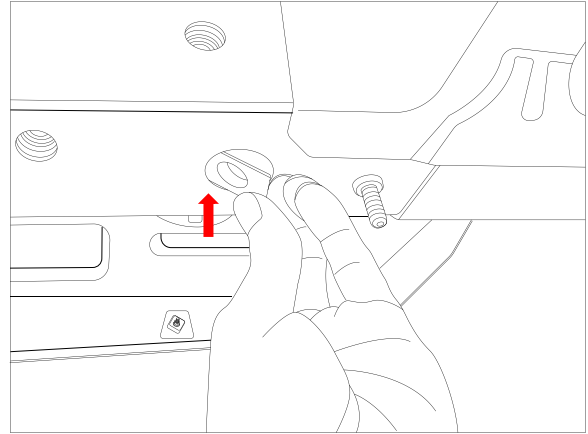

11. Fit the LHS side arm and loosely secure with 3x M12 bolts and 3x M12 washers.

Loosely secure with 1x M10 bolt and 1x M10 washer.

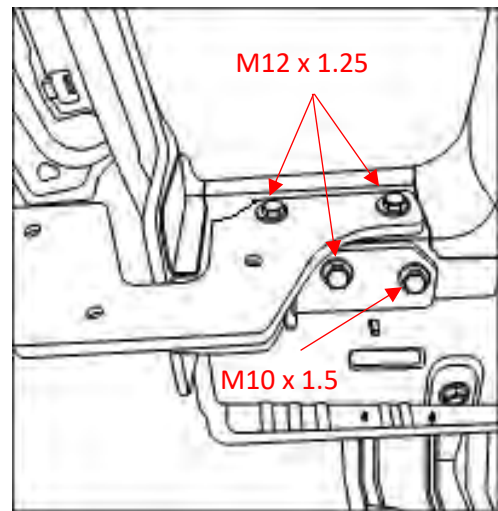

12. Fit the RHS side arm and loosely secure with 3x M12 bolts and 3x M12 washers.

Loosely secure with 1x M10 bolt and 1x M10 washer.

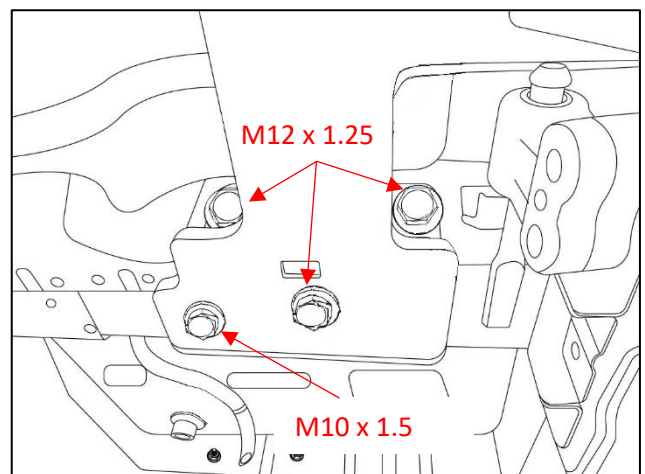

13. Fit the cross tube between the side arms.
Loosely secure with 3x bolts, 5x washers and 2x nuts.

Repeat for the other side.

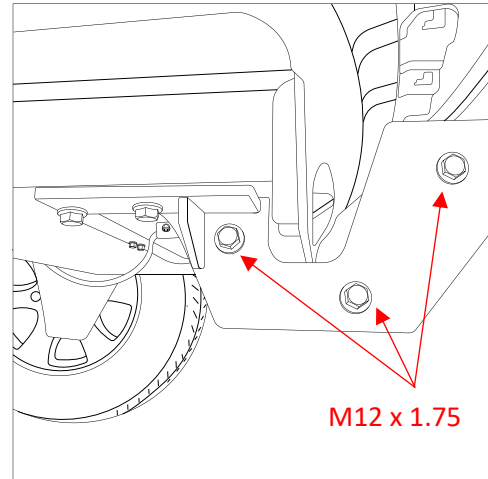

14. Torque all bolts:

Torque Spec:

M10 x 1.5 = 62 Nm

M12 x 1.25 = 125 Nm

M12 x 1.75 = 109 Nm

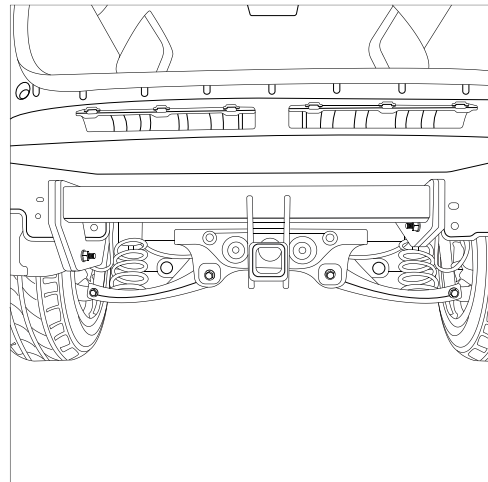

15. Mark and cut off 20mm from the hole and 50mm from the base of the plastic cover removed on step 5.

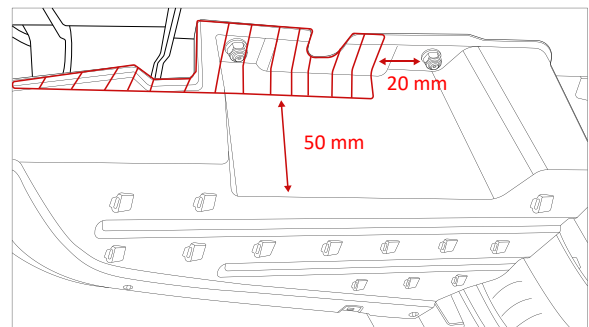

16. Remove the wire harness by cutting the wire fir tree clips on the impact beam.
Unclip 5x scrivets from the impact beam.
Remove 2x screws and disconnect the antenna.

Remove and discard the impact beam.

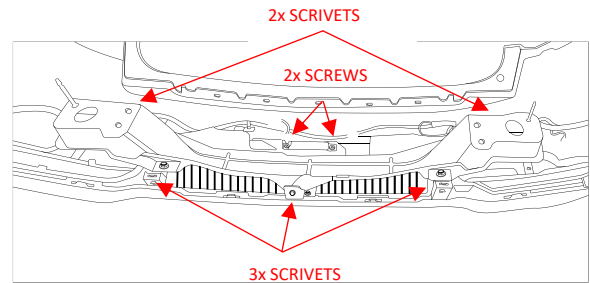

17. On LHS, secure the bumper tab bracket to the towbar using a screw.

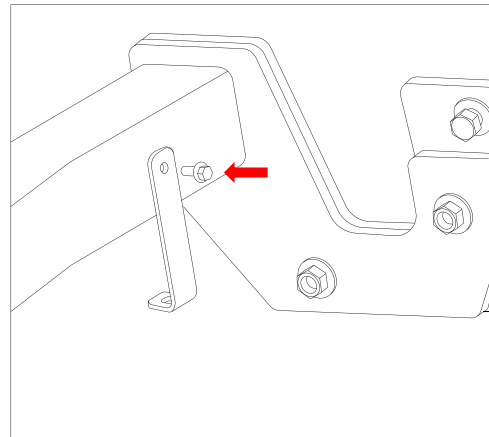

18. On RHS, secure the bumper tab bracket to the towbar using a screw.

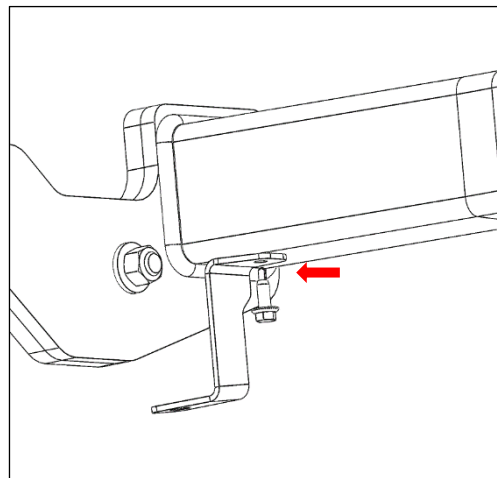

-
19. Secure the bracket to the towbar using a screw.
Secure the antenna to the bracket using 2x screws and 2x nuts.

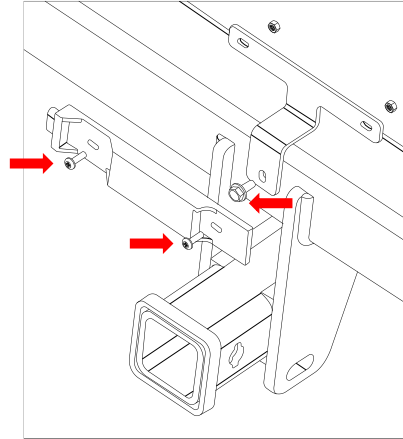

-
20. Cut out template on page 16.
Place template to the bumper outer skin.
Mark and cut out the area of the bumper.

Locate the plug bracket and ensure the harness cable length is long enough.
Drill 2x $\varnothing 5\text{mm}$ holes 69mm apart

Remove all swarf and rough edges.

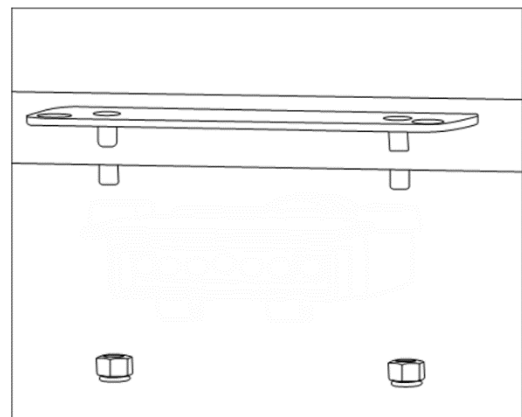

IMPORTANT

Due to possible vehicle variations, always confirm any noted vehicle colour wires with a multi-meter to ensure the correct function is identified before soldering or scotch locking. For vehicle wires denoted with two colours (example; RED/GREEN) the first colour will always be the main wire colour while the second colour is the thinner trace colour on the wire.

21. In the Engine Bay, disconnect the vehicle battery negative terminal.
22. In the luggage compartment, open the rear storage tray lid.
23. Fold down the second and third row seats (1).

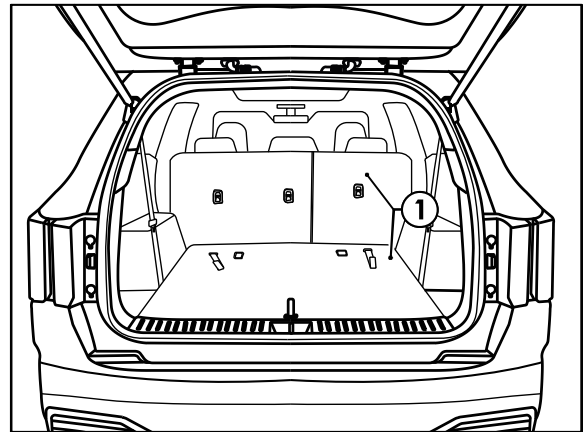

24. Remove the tool storage tray (1)
25. Remove the three caps covering the screws securing the rear storage tub screws (2).
26. Remove the three screws and then remove the rear storage tub (3) by lifting up.

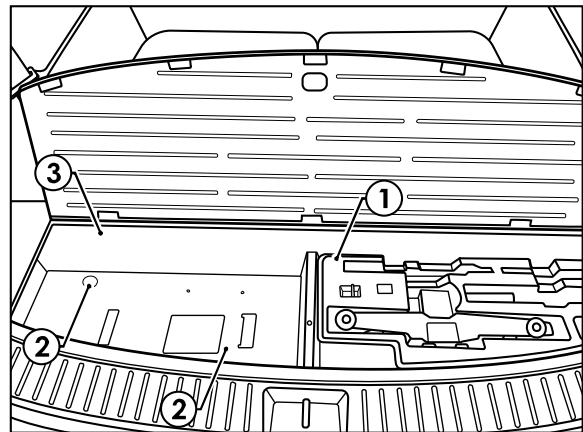

27. Remove the rear scuff trim (1) by lifting up.

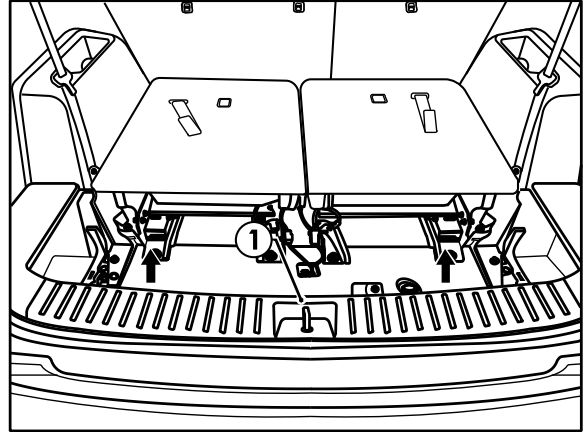

28. Remove the two rear bolts (1) on the LHS third row seat (2).
29. Disconnect the seatbelt warning connector (3) on the LHS seat.

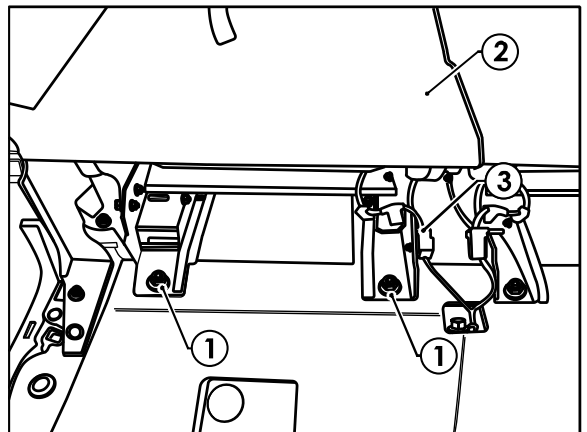

30. From the LHS rear passenger door, remove the last two bolts (1) securing the LHS third row seat (2) by lifting up the bolt covers.
31. Remove the seat from the vehicle.

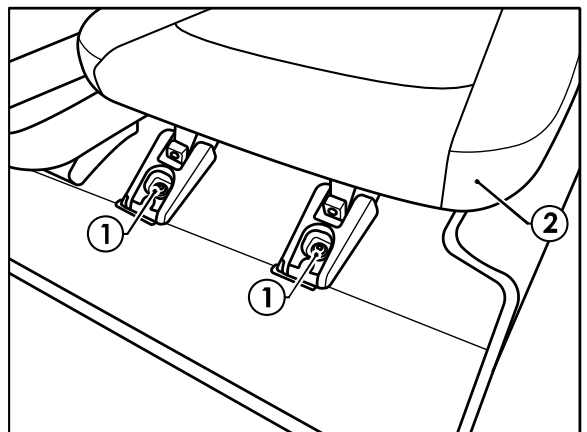

32. On the LHS, remove the two screws (1) securing the luggage compartment trim (2).
33. Fold the LHS luggage compartment trim inwards.
34. Disconnect USB connector if present.

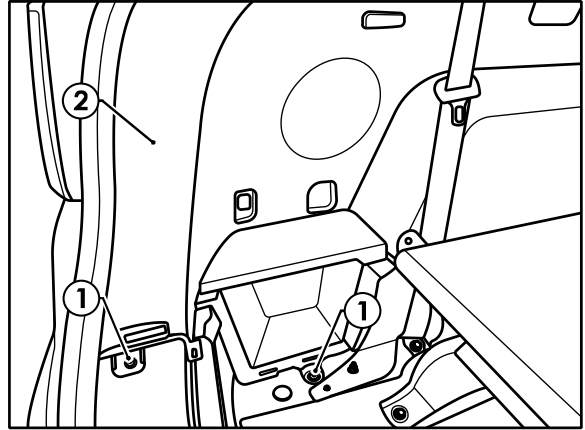

35. Behind the LHS trim, locate the vehicle 6-way prewire connector (1).
36. Connect the vehicle prewire connector to the mating connector on the patch harness (WLL90022).

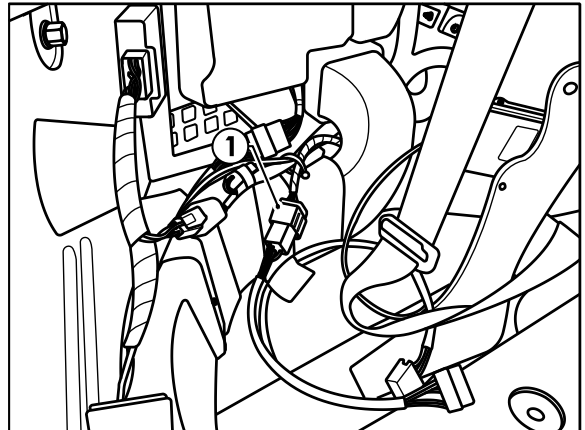

37. Using an alcohol wipe, clean the LHS inner sheet metal area (1) and the underside of the ECU (WLL70022) (2).
38. Connect the trailer patch 18-way connector (3) to the ECU (2).
39. Apply double sided tape to the ECU and secure it to the vehicle sheet metal.

Note: Mount the ECU, ensuring the connector is orientated downwards.

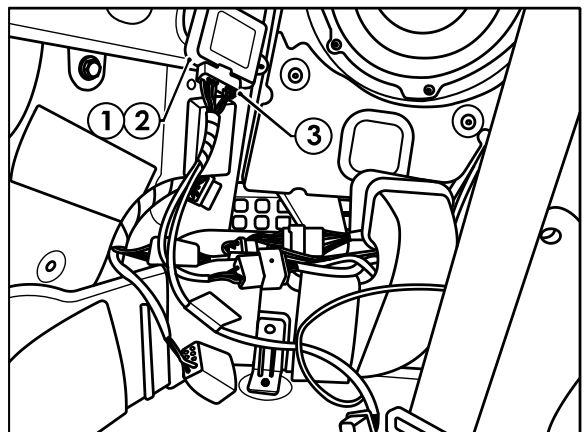

40. Secure the ring terminal (1) to the vehicle earth point (2) near the rear left door.

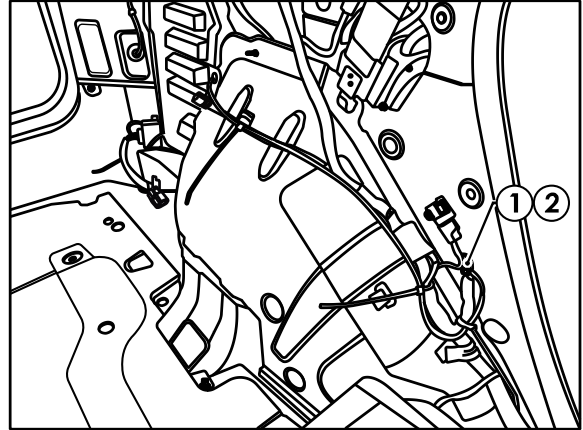

41. Drill a 30mm grommet hole (1) in a suitable location to enable the tail harness to be routed from the towbar to the ECU.

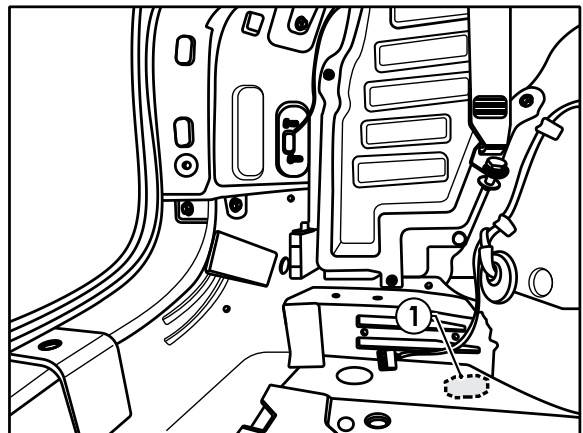

42. With the rear bumper removed, secure tail harness (1) to towbar.
43. **If Automatic RPA Disable use 04936 ensure the Grey, Grey/Black wires must stay outside the vehicle.**
44. Seat grommet in 30mm hole and route to trailer harness blue connector on patch loom.

Note: Keep harness routing clear of all sharp edges, moving parts and places of extreme heat.

Note: Ensure grommet is seated correctly and makes a good seal.

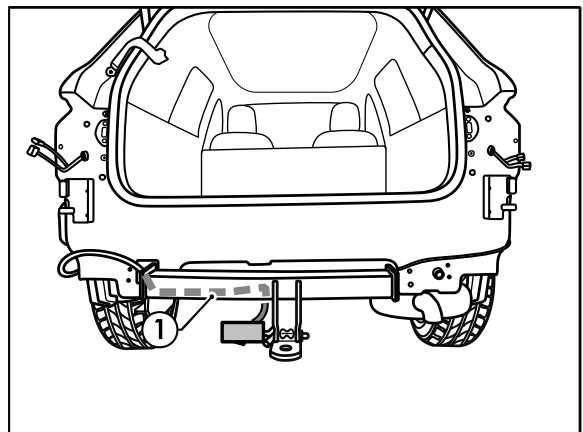

45. Patch in the T-Patch (3) between the vehicle harness 12-way connector (4) and the bumper harness connector (5).
46. Strip and crimp and seal the tail harness GREY and GREY/BLACK wires (1) to the T-patch GREY and GREY/BLACK wires (6).

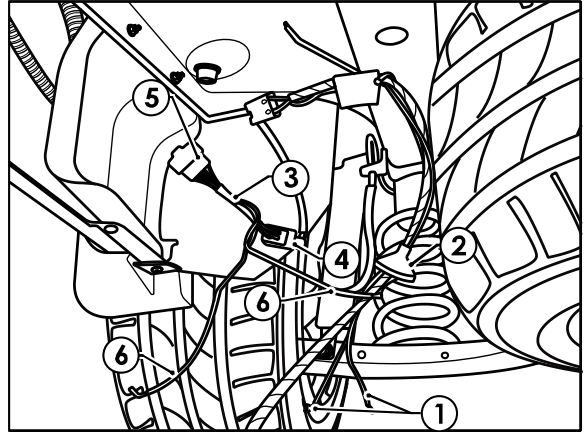

47. Test the trailer patch function using a light board or multi-meter.
48. Place the plug bracket on the previously drilled out hole on the bumper.
49. Re-fit all removed parts and secure all fasteners, ensuring there are no squeaks or rattles.
50. Place the fitting instructions in the glove box after fitment.

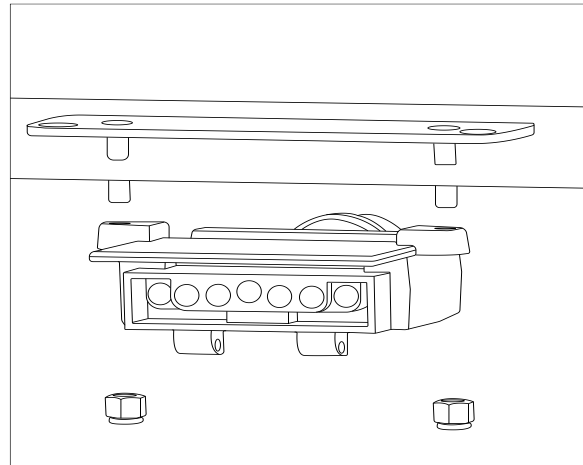

Bumper Cut Out Template

1. Measure the template to ensure all dimensions are to scale before cutting.
2. Mark the center line on the painted surface of bumper.
3. Place the template on the outside of the bumper.
4. Align the center line of the bumper and the template.
5. Align the lowest edge of the bumper and the template.

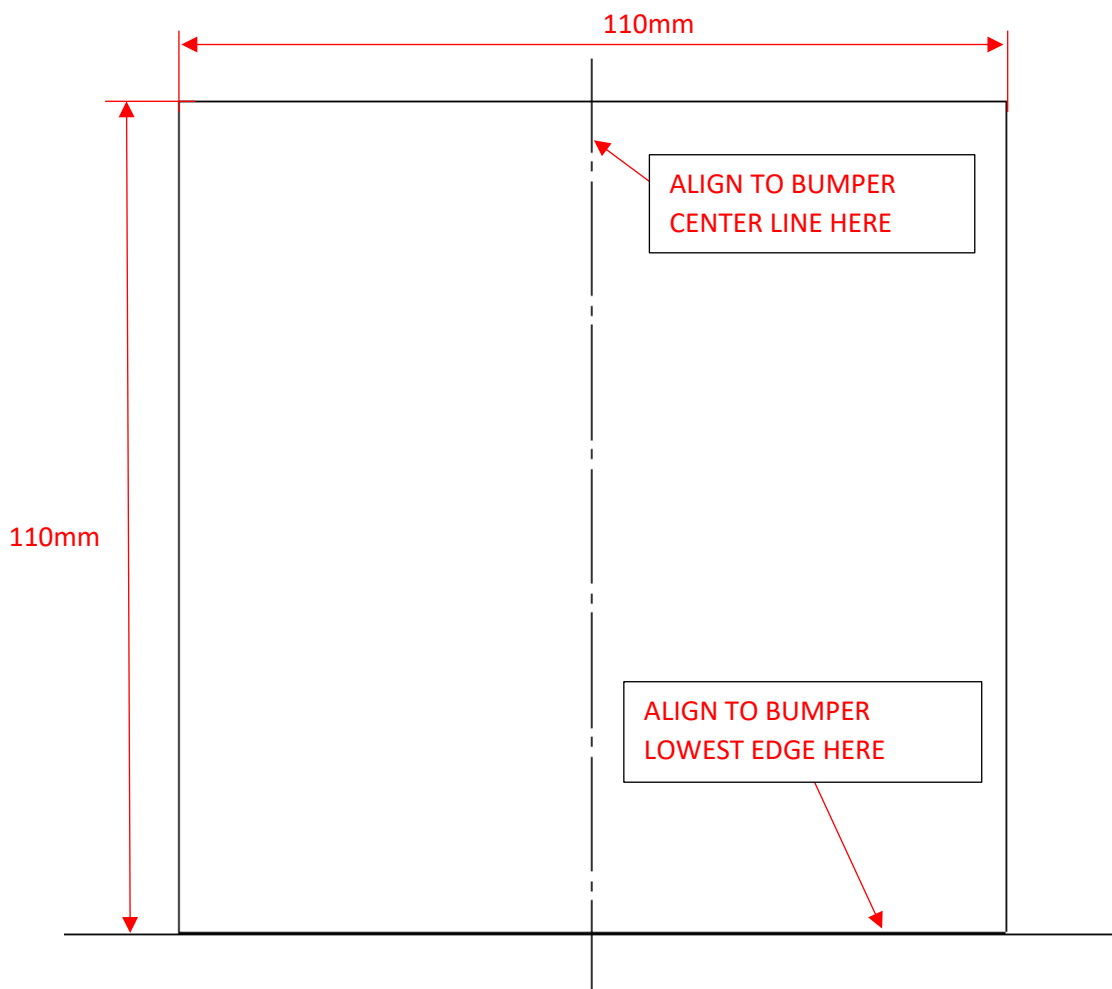



CUSTOMER INFORMATION

PLACE THESE INSTRUCTIONS IN THE
VEHICLE'S GLOVEBOX AFTER INSTALLATION

**THANK YOU FOR PURCHASING TRAILBOSS. WITH CORRECT MAINTENANCE AND CARE
THIS PRODUCT WILL PROVIDE A LIFETIME OF TROUBLE-FREE OPERATION.**

TOWBAR MAINTENANCE AND CARE:

1. Trailboss recommend that the towbar LUG or TBM (Trailer Ball Mount) Pull Pin and R-clip are removed and stored when not in use. Removal of LUG or TBM (Trailer Ball Mount) is advisable when not in use to assist with any of the following.
 - Ensure rear number plate is not obscured.
 - Allow maximum available departure angle and prevent any potential interference.
 - Prevent possible interference with vehicles reverse sensors or camera detecting a tow ball mount as an obstruction during reversing.
 - Removes towball mount as an obstruction for when moving around the rear of the vehicle.
2. Trailboss recommends routine inspection of your towbar to ensure trouble free towing.
 - Bolt security and tension should be regularly inspected and checked for correct tension. Replace any worn or defective parts with suitable grade & class fasteners. Inspection should be requested to coincide with vehicle major services.
3. It is the owner's responsibility to ensure towing and down ball weight capacities of the towing vehicle are not exceeded.
 - Towing and down ball weights allowable may differ according to model variations. Please refer to owner's manual or vehicle dealer to confirm exact rating for your vehicle model variant.
 - It is not uncommon for the vehicle tow rating to differ from the towbar rating. When this occurs, the lesser rating must be adhered to.
 - For vehicles fitted with enhanced vehicle functions that may be altered/changed when towing i.e Trailer sway mitigation, blind spot detection, adaptive cruise control etc. Please consult owner's manual to understand changes enabled when towing and after towing.

WARRANTY INFORMATION:

Trailboss Towbars are covered by a Lifetime Warranty.

Our goods come with guarantees that cannot be excluded under the Australian Consumer Law. You are entitled to a replacement or refund for a major failure and for compensation for any other reasonably foreseeable loss or damage. You are also entitled to have the goods repaired or replaced if the goods fail to be of acceptable quality and the failure does not amount to a major failure.

For further details please contact customer service on 1800 812 017.

PRO SERIES SILENT ANTI-RATTLE HITCH PIN

Your Trailboss towbar is equipped with a Pro Series Silent Anti-Rattle Hitch Pin technology to help reduce towbar tongue rattle in most driving conditions. Please ensure below instructions are understood and routine maintenance is carried out to ensure best towing experience.

Regularly inspect for wear and check the tightness of the Silent Anti-Rattle Hitch Pin. Follow instructions below to re-tighten the nut as necessary when movement and noise in the tow ball mount is noted.

- Before towing, ensure R-Clip is properly installed and hitch pin nut is installed and tensioned. Replacement parts are available from your Pro Series Distributor.

TOWBALL MOUNT REMOVAL/INSTALLATION

STEP 1

Insert Trailer Ball Mount (TBM) (a) into towbar hitchbox (b), aligning hole in TBM shank (c) with hole in hitchbox (d) (Fig. 1)

STEP 2

Insert Silent Anti-Rattle Hitch Pin (e) through hole in hitchbox and hole in TBM shank (g); ensure the locators are inserted into the notches in the hitchbox (Fig. 2)

STEP 3

Screw Silent Anti-Rattle Hitch Pin Nut (f) onto Smart Pin (g); tighten Smart Pin Nut until finger tight, ensuring TBM is restrained from up and down movement.

STEP 4

Tighten Silent Anti-Rattle Hitch Pin Nut by turning nut a further 1/8th of a turn in the clockwise direction using a 24mm spanner (Fig. 4).

STEP 5

Install Silent Anti-Rattle Hitch Pin R-Clip through the hole that provides best clearance or easiest access. (Fig. 5)

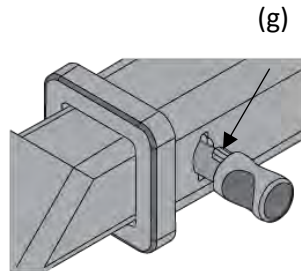
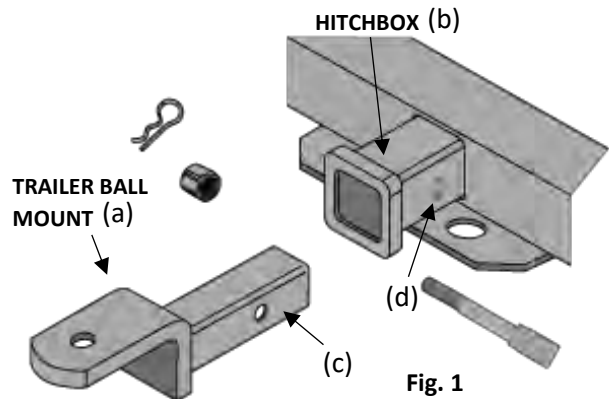

Fig. 2

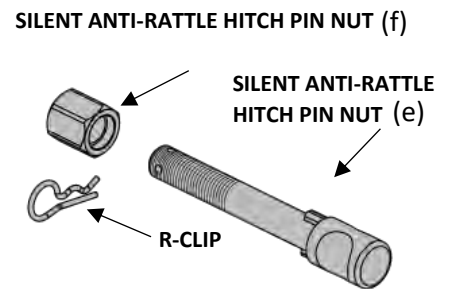

Fig. 3

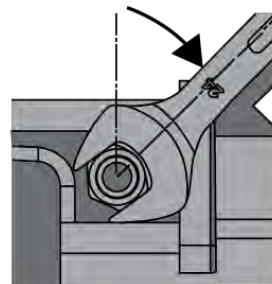

Fig. 4

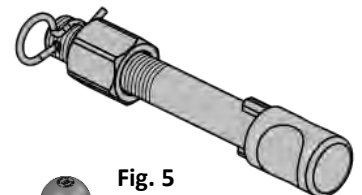

Fig. 5

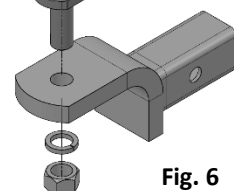

Fig. 6